

BRETT Aqua Line

714 891 7211

CALL with Question
Concerning operation
88-89

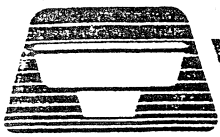



CONTENTS

Important Safety Instructions	2	Start-up Procedures	
Spa System Components	3	Operating Instructions	
Spa Installation		Spa Side Control Function	11
Outdoor Installation	4	Hydro-Massage Jets	11
Indoor Installation	4	Jet Selector Knob	12
Electrical Information		Setting the Temperature	14
120 Volt Installation	5	Helpful Hints	14
240 Volt Installation	5	Comfort Timer	14
Conversion from 120V to 240V	6	Maintenance	
Equipment System	7	Spa Cabinet Care	17
Equipment Control Panel	8	Draining	17
Filtration Time Clock	9	Water Testing and Chemical Treatment	17
Heating Time Clock	10	Cleaning	17
		Filter Maintenance	17
		Winterizing	17
		Replacing Pedestal Mood and	
		Underwater Spa Light Bulbs	16
		Problem Solving Guide	19
		Warranty	20
		Spa Soaking Guidelines	20

OWNER'S RECORD

Date Purchased _____

Purchased From _____

Installed By _____

Serial Number _____ Model _____

SAVE THIS INFORMATION FOR FUTURE USE

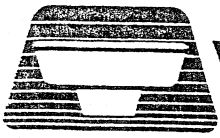

IMPORTANT SAFETY INSTRUCTIONS

CAUTION: RISK OF ELECTRICAL SHOCK. READ AND FOLLOW ALL INSTRUCTIONS

1. Take special care to make sure your spa has a level, solid foundation. You must install your spa to provide drainage away from the electrical component compartment.
2. Do not install your spa on any combustible surface or near any combustible material.
3. The very young, or aged, those with illness, heart conditions or under doctor's care should not use the spa unattended. Infants should not be permitted in the spa at water temperatures over 100°F.
4. **DANGER: To reduce the risk of injury, do not permit children to use this product unless they are closely supervised at all times.**
5. Special care should be taken when using the spa and consuming alcoholic beverages. Alcohol, drugs, and some medications affect a person's ability to withstand the high temperatures and could produce dangerous effects.
6. Do not use electrical appliances such as television, radio, lights, cooking devices, or telephones within 10 feet of the spa while the spa is being used. Lighting fixtures must not be located directly above or within 10 feet of the spa. Lighting fixtures located within 20 feet of the spa must be on a circuit protected by a GFCI.
7. Do not use an extension cord to power your spa. This may cause an electric shock or may permanently damage your portable spa and may void the warranty.
8. Do not plug in the spa unless it is filled with water to the normal water level 6" below the top of the spa lip. Starting the spa when the water level is low can damage the circulation pump and heater and could cause a fire.
9. Keep your water chemistry correctly balanced. Untreated spa water will cause problems with your spa and support equipment. Maintaining the correct balance is simple if you just take time to read your test kit instructions and check your water regularly. (Damage to your spa or equipment due to improper water balance will not be covered by warranty.)
10. Clean your filter about once a month if you use the spa frequently. Do not allow people in your spa with suntan lotion or other oils on their skin. It will coat and inhibit efficient filter operation.
11. Do not allow hair and clothing within twelve inches (12") of skimmers, suction fittings or drains at any time. Persons with long hair should either secure hair to a minimum length or wear a bathing cap. **DANGER — To reduce risk of injury, do not remove suction grate or cover.**
12. The wet surface of the spa is slippery. Enter and exit the spa slowly and cautiously.
13. After use, immediately replace your cover. Using a spa cover will save you in utility costs, keep your spa cleaner and provide added safety when the spa is left unattended. Moreover, since the spa stays warmer, it heats up faster and is more convenient to use. Note: Spa cover is not capable of supporting weight of people. Do not allow anyone to stand on the cover.
14. Be sure to align the equipment cabinet door and secure with the door latch. It is necessary to have the equipment panel door properly in place to operate the spa.
15. Do not lift the spa from the top edge of the equipment panel door housing. This could damage the spa cabinet. Always lift the spa from the bottom!
16. (Cord-connected units) Connect only to a properly grounded dedicated receptacle.
17. Check GFCI for proper operation prior to use. See equipment control panel, page 8.
18. **MAKE SURE YOU HAVE A LICENSED PROFESSIONAL MAKE THE FINAL ELECTRICAL CONNECTIONS.**
19. (Cord-connected units) Do not bury cord.
20. **WARNING - To reduce the risk of electrical shock, replace damaged cord immediately.**

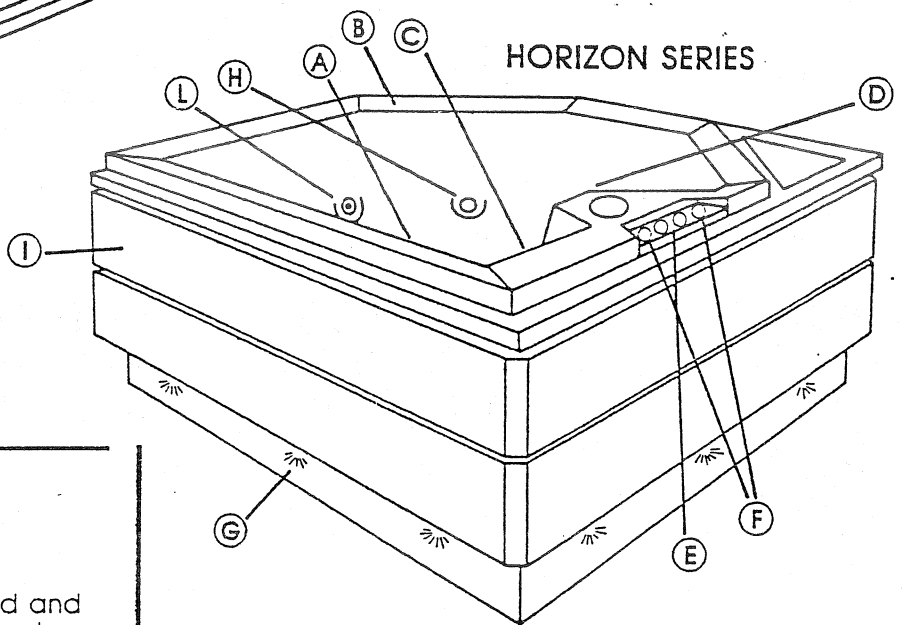
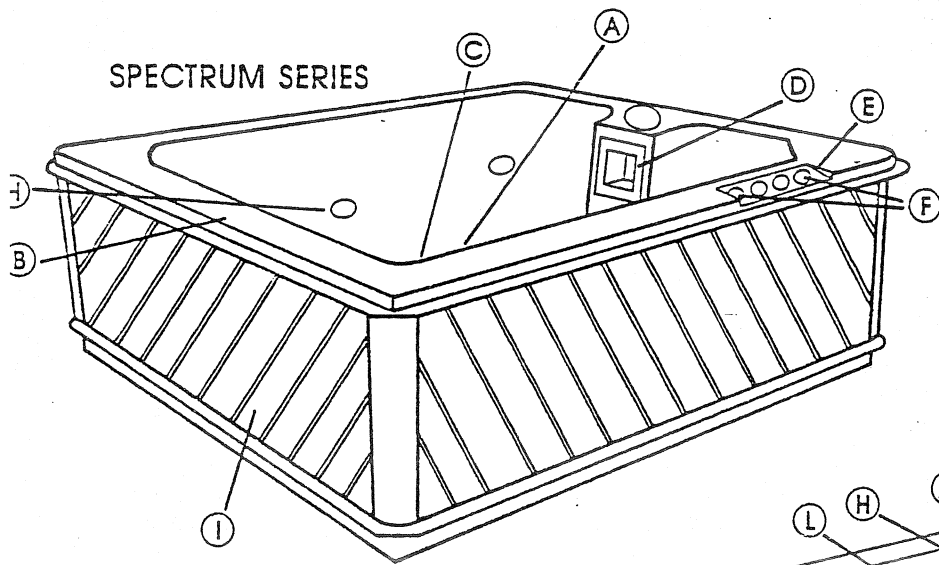
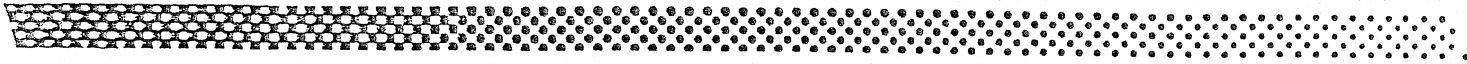

SPA SYSTEM COMPONENTS

- (A) **UNDERWATER SPA LIGHT** - Helps set mood and provides added safety while entering and exiting your spa.
- (B) **SPA SHELL** - Acrylic/fiberglass spa shell, insulated with Thermo-Lock™ foam system.
- (C) **SAFETY SUCTION FITTING** - Returns water to Equipment Pak for heating and filtering.
- (D) **FILTER SKIMMER/WEIR DOOR** - Removes floating debris from the water surface, provides a water return path to equipment, and houses water filter element.
- (E) **SPA SIDE CONTROL PANEL** - Used to control temperature setting, pump for hydro jets, air blower for massaging bubble action, and light.
- (F) **AIR MIXTURE CONTROLS** - Increases or decreases air entering the hydro-massage jets (should be closed when heating).
- (G) **PEDESTAL MOOD LIGHTING (Horizon Only)** - Adds beauty and safety to your spa area. It will illuminate approximately 3' around the cabinet.

- (H) **HYDRO-MASSAGE JETS** - Adjustable and directional water jets return water into the spa mixed with air provides a concentrated body massage. The flow of each jet can be adjusted by turning the knurled eyeball clockwise or counterclockwise.
- (I) **CABINET** - Beautiful handcrafted wooden cabinet. Quality built and factory treated to stand up to the elements and provide protection for spa plumbing and equipment.
- (J) **EQUIPMENT PAK** - Spa support system consisting of 2-speed pump, water heater, air blower, filter, and associated electrical controls (not shown).
- (K) **COVER** - Spa cover that protects and insulates. It should be securely in place when the spa is unattended. (not shown)
- (L) **WHIRLPOOL JETS (Horizon Only)** - Directs water in a circular motion around the spa.

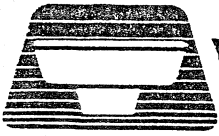

SPA INSTALLATION

BE SURE TO READ THE FOLLOWING INFORMATION BEFORE CONNECTING YOUR SPA TO AN ELECTRICAL SOURCE!

DANGER: RISK OF ELECTRICAL SHOCK.
INSTALL AT LEAST 5 FEET FROM ALL METAL SURFACES.

OUTDOOR INSTALLATION

Keep the following factors in mind when installing your spa outdoors.*

1. Local codes pertaining to fencing.
2. Local electrical and plumbing codes.
3. View from your house.
4. Wind direction.
5. Exposure to sunlight.
6. Location in regard to trees (falling leaves and shade problems).
7. Dressing and bathroom location.
8. Storage area for maintenance equipment and chemicals.
9. Location to facilitate adult supervision.
10. Landscaping and nighttime lighting.
11. Easy access to Equipment Pak door.
12. Power cord location and foot traffic.

*If your spa is installed outdoors, we recommend that you provide a concrete pad for the spa to rest on (8 x 8 x 4" thick level pad).

INDOOR INSTALLATION

1. Indoor spas promote high humidity, so a means of decreasing this humidity must be

provided. This can be accomplished by using either ventilation fans or oversized dehumidifiers. Consult your dealer.

2. Floor drains should be provided to drain off water splashed from the spa which may cause walking hazards and/or water damage.
3. Floor area should be flat and noncombustible.
4. Walls, ceilings, woodwork should be of materials capable of withstanding high humidity (redwood, cedar).
5. Be sure floor load bearing capacities are adequate to support the concentrated spa weight.
6. Spas should be double checked for leaks before taking inside to avoid possible water damage.

GENERAL

Locate the spa on solid, level ground, foundation or flooring. Keep in mind the weight of the filled spa (in excess of 4,000 lbs. on some models). If you have any doubts about the load bearing ability of your chosen site, contact an architect, your building department, or other knowledgeable authority. **It is important that the entire perimeter of the spa cabinet and the spa bottom are evenly supported.**

Should you install your portable spa below floor level you must provide room to allow access for servicing from above or below the floor. **Your spa must be installed to provide drainage for the electrical compartment.**

Because of equipment accessibility and drainage problems, the manufacturer recommends that you do not install below floor level.

ELECTRICAL INFORMATION

CAUTION: RISK OF ELECTRICAL SHOCK. READ AND FOLLOW ALL INSTRUCTIONS

IMPORTANT SAFETY INSTRUCTIONS

Prior to performing any service to the spa package turn OFF ALL primary electric power at the main circuit breaker or disconnect panel.

All field electrical connections can be made by removing the front cover of the electrical control box.

All electrical connections to this spa package must be accomplished by a qualified electrician in accordance with the National Electric Code or the Canadian Electric Code and in accordance with any local electrical codes in effect at the time of installation.

All connections should be made in accordance with the wiring tag enclosed in the electrical control box or the wiring diagrams within this manual.

This equipment is designed to operate on 60Hz Alternating Current only, at a voltage of 120 or 240 volts as required.

Connections should be made using copper conductors only. The connecting wire and circuit breakers or fuses must all be sized to accommodate the Total Ampere load as specified on the equipment module data label.

(Cord-connected units) Connect only to a properly grounded dedicated receptacle.

(Cord-connected units) A pressure wire connector is provided on the surface of the control box inside the spa to permit connection of a bonding wire between this point and any metal equipment, metal enclosures of electrical equipment, metal water pipe or conduit within five feet of the unit as needed to comply with local requirements. The bonding wire must be at least a No. 8 AWG solid copper wire.

(Permanently-connected units) A green colored terminal (or a wire connector marked "G," "GR," "Ground," or "Grounding") is provided with the control box. To reduce the risk of electric shock, connect this terminal or connector to the grounding terminal of your electric service or supply panel with a continuous green insulated copper wire equivalent to the circuit conductor supplying this equipment, but no smaller than No. 12 AWG. In addition, a second wire connector is provided for bonding to local ground points. To reduce the

risk of electric shock, this connector should be bonded with a No. 8 AWG copper wire to any metal ladders, water pipes, or any metal within 5 feet of the tub.

(Cord-connected units) This equipment is provided with a ground fault circuit interrupter on the equipment panel. Before each use, with the plug connected to the power supply, and with the spa operating, push the test button. The spa should stop operating and the reset button should appear. Push the reset button. The spa should now operate normally. If the interrupter fails to operate in this manner, there is a ground current flowing, indicating the possibility of an electrical shock. Disconnect the plug from the receptacle until the source of the breakdown has been identified and corrected.

120 VOLT INSTALLATION

CONNECT TO GROUNDED TYPE RECEPTACLE ONLY

Electrical Requirement: 120 Volts, 60Hz, Single-Phase, 20 amp., grounded receptacle.

Equipment modules wired for 120 volt operation require a 3 wire electrical service (line 1, black), (neutral, white) and (ground, green). Refer to terminal block diagram on page 6.

Models 120 and 140 are wired for 120 volt, cord-connected operation from the factory. All other models must have all electrical connection made by a qualified licensed electrician, in accordance with the national electrical code. Other appliances or electrical equipment **cannot be used** on this circuit.

Be sure to isolate the power cord from all foot traffic areas to prevent cord damage or tripping accidents. Route the cord through the hole in the cabinet provided for this purpose.

240 VOLT INSTALLATION

Electrical Requirement: 240 Volts, 60Hz, Single-Phase, 50 amp., 4 wire service.

Units to be operated at 240 volts must have all electrical connections made by a qualified electrician in accordance with the National Electric Code, the Canadian Electrical Code or other local electrical codes in effect at the time of installation.

Equipment modules installed for 240 volt operation require a 4 wire, 50 amp., 240 volt subfeed in non-metallic pipe to the spa equipment compartment (line 1, line 2, neutral and ground). Refer to terminal block diagram on page 6. Take precautionary steps to ensure that all procedures regarding the conversion information have been implemented. See page 6.

ELECTRICAL INFORMATION

TERMINAL BLOCK DIAGRAMS

NOTE: COPPER CONDUCTORS ONLY

120 VOLT WIRING DIAGRAM

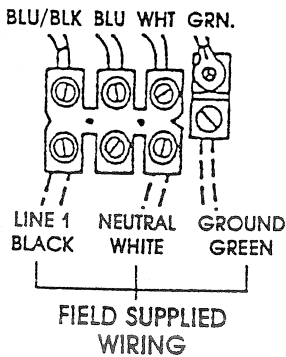

240 VOLT WIRING DIAGRAM

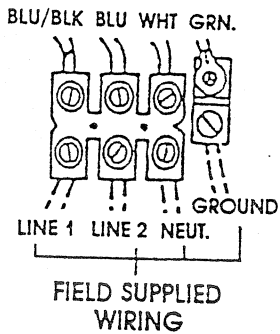

CONVERSION FROM 120V to 240V

Disconnect all electrical power to the equipment before attempting conversion.

Inside the control box, disconnect the 120 volt factory-supplied cord from the terminal block using a standard screwdriver.

Using pliers, squeeze the pressure fitting (located on the bottom of the control box) which holds the cord in place. This allows removal of the cord.

CONVERSION PLUG DIAGRAM

Inside the control box, disconnect the blue plug from the 120 volt receptacle as shown in the conversion plug diagram and reconnect into the 240 volt receptacle.

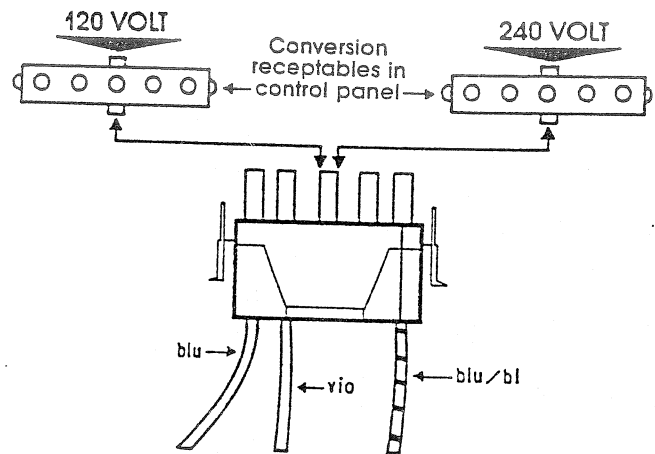

EQUIPMENT SYSTEM

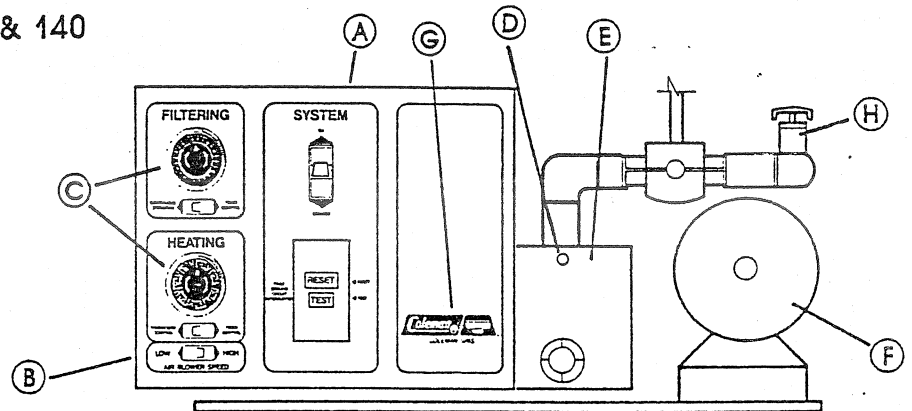
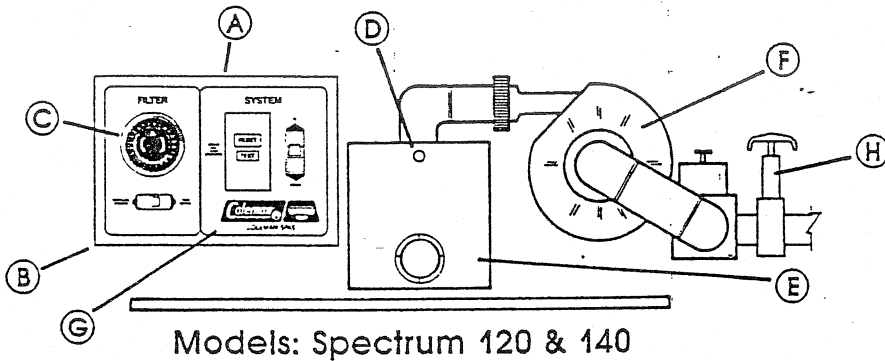

- (A) **Air Blower** - Provides a large volume of air to the air holes in the floor and/or seat of the spa for a vigorous bubble action (behind control box).
- (B) **Electrical Control Box** - Contains the remote control mechanism and provides a central connection point for all electrical components.
- (C) **Time Clocks** - Can be set to filter and heat water automatically.
- (D) **High-Limit Switch** - The electric heater in the Equipment Module is equipped with a high-limit safety switch that will shut the heater OFF if the temperature within the heater assembly reaches a factory-set, high temperature limit.

Several conditions could cause the high-limit switch to turn the heater OFF:

1. Water level in spa too low
2. Valves in plumbing closed while Heater is on
3. Plumbing lines plugged, restricting water flow
4. Dirty filter, impeding water flow
5. Defective or inoperative pump
6. Faulty heater thermostat
7. Unusually high temperature under spa skirt

The high-limit switch cannot be re-set until the temperature within the heater assembly drops several degrees. Should the high-limit switch trip repeatedly, the Equipment Module should not be operated until the problem has been corrected. Contact your local dealer to remedy this problem.

- (E) **Heater Assembly** - Thermostatically controlled and equipped with a high-limit safety shut-off.
- (F) **Two Speed Pump** - Low speed for efficient water circulation during filtration and heating. High speed for maximum action of the hydro jets (not shown).
- (G) **Manufacturer's Identification Label**
- (H) **Slice Valve** - Used to shut off water flow from the spa to the equipment pak, while servicing. When cleaning the filter (Model 120 & 140), close the slice valve on the pump side to prevent air bubbles from entering the pump.

EQUIPMENT CONTROL PANEL

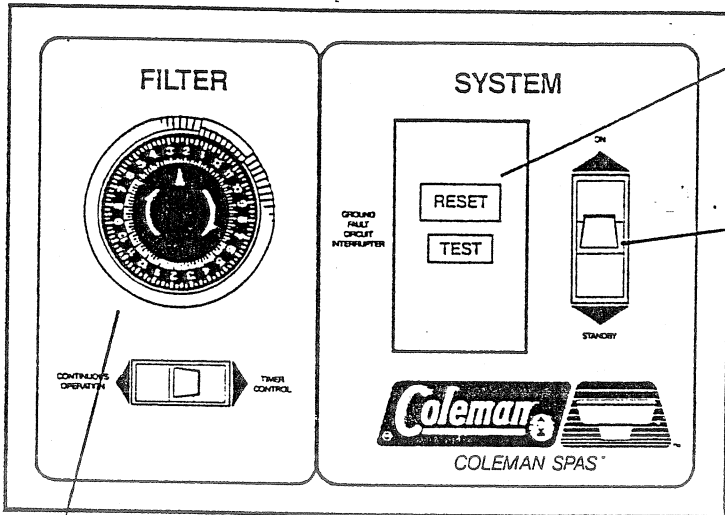

Models: Spectrum 120 & 140

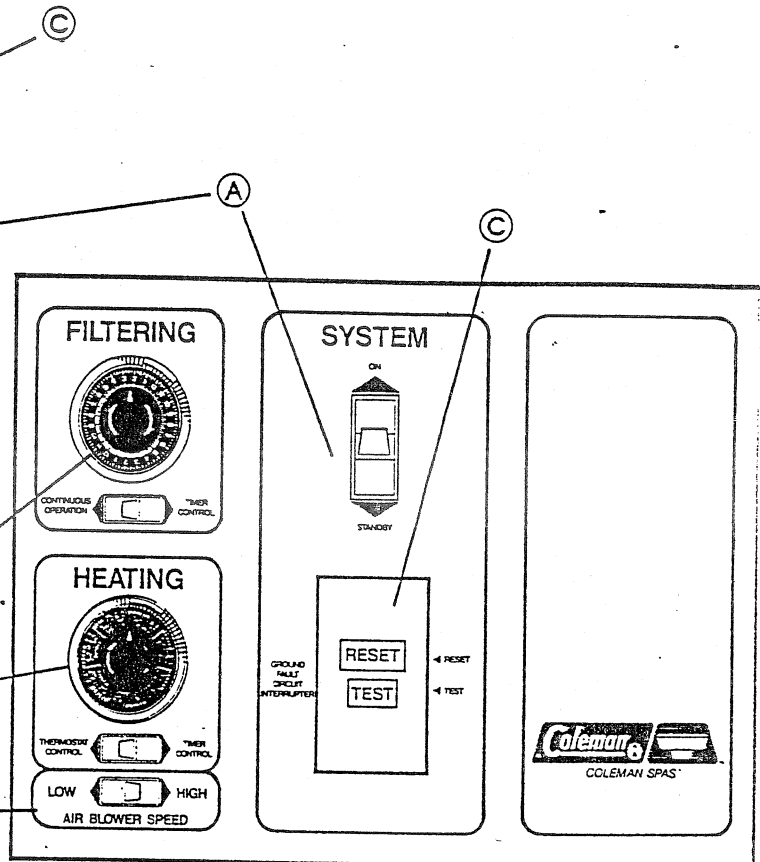

Models: All Horizons and 155

(A) Main Power Switch - Used to turn all electrical components of the Equipment Module ON and OFF.

(B) Filtering Time Clock

(C) GFCI - The Ground Fault Circuit Interrupter should be tested periodically to confirm that it is providing maximum protection. Test as follows:

1. Depress and release TEST button. RESET button pops outward.
2. Depress and release RESET button. RESET button will stay depressed.

If the GFCI does not operate in this manner, disconnect power from the pack until a qualified service technician has corrected the problem.

(D) Heating Time Clock

(E) High/Low Blower Switch - This function works only when the system is wired for 240 volt. You may select high for vigorous bubbles or low for soft massaging bubbles.

FILTRATION TIME CLOCK

The filtration time clock built into the equipment control console provides the ultimate in operating convenience and economy. The spa water can be filtered daily or several times each day to maintain a sparkling clear, clean condition with ideal chemical distribution. The water temperature can be automatically controlled to be ready to use whenever desired, either day or night. The two time clocks operate independently of each other and may be overridden at any time while using spa on the high speed modes. Filtration times vary depending on use, however a good recommended starting point is 4 hours per day.

FILTRING TIME CLOCK - 24 HOUR OPERATION (on all Spectrums and Horizons)

(A) Clock Set Point - Rotate outer clock ring clockwise and set correct time of day opposite Set Point Arrow.

For an initial setting, try two 60-minute ON settings spaced evenly around the clock. Wait a few days and adjust as necessary to maintain sparkling clear water with the minimum of ON times.

(B) Time Clock Lugs - Push inward toward center of clock to set ON times. Each lug represents a 15 minute time period. Any combination of cycles is possible. The example shows ON at 11:00 AM and OFF at 1:30 PM. To cancel settings push outward on the lugs.

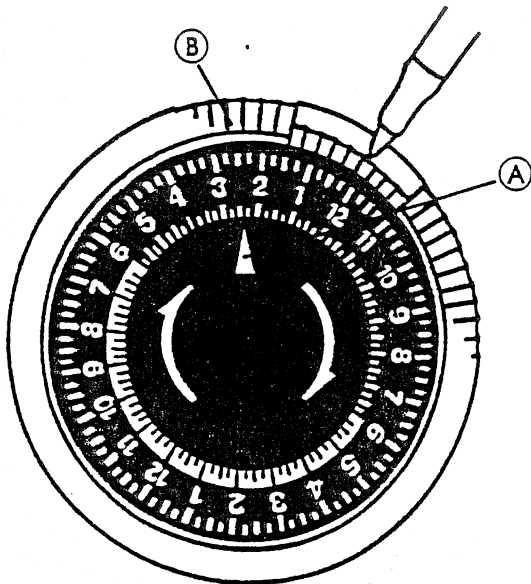

FILTRING BY-PASS SWITCH

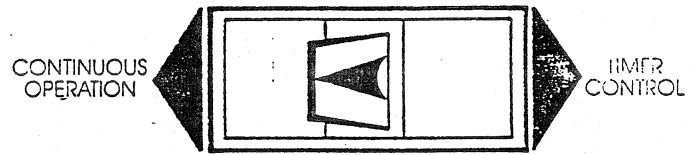

In this position, the filtration cycle will run continuously. Use this when extra filtration is desired following periods of heavy spa usage or when adding chemicals and during extreme cold weather (below 40 degrees) to inhibit system freeze up. The time clock settings are not disturbed and timed cycles will begin again when this switch is returned to the TIMER CONTROL position.

On models 120 and 140 only — The heater comes on as called for by the thermostat.

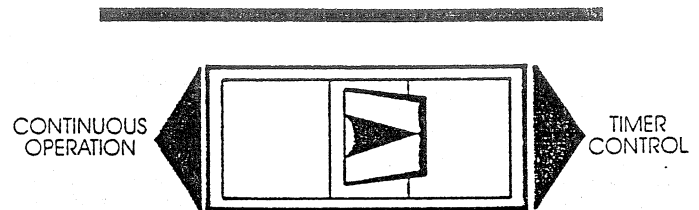

In this position the time clock has control and will start and stop the filtration cycle as determined by the settings of the FILTERING time clock lugs.

On models 120 and 140 only — This enables the thermostat to override the timer control when the thermostat calls for heat.

HEATING TIME CLOCK

HEATING TIME CLOCK: 7 DAY OPERATION (All Horizons and Spectrum 155 only)

- (A) Clock set point - Rotate outer clock ring clockwise and set correct time of day opposite set point arrow.

If the thermostat is calling for heat and the time clock reaches an ON time, the pump will start and the heater will turn ON. When the water reaches the desired temperature the thermostat will turn the heater and the pump OFF. This cycle will continue during each ON period as determined by the setting of the time clock lugs. The HEATING time clock should be set for heating during your normal hours and days of usage.

- (B) Time Clock lugs - Push inward toward center of clock to set ON time. Each lug represents a 2 hour period of a selected day of the week. The example shows ON at 6:00 AM Friday and OFF at Midnight Friday. To cancel settings push outward on the lugs.

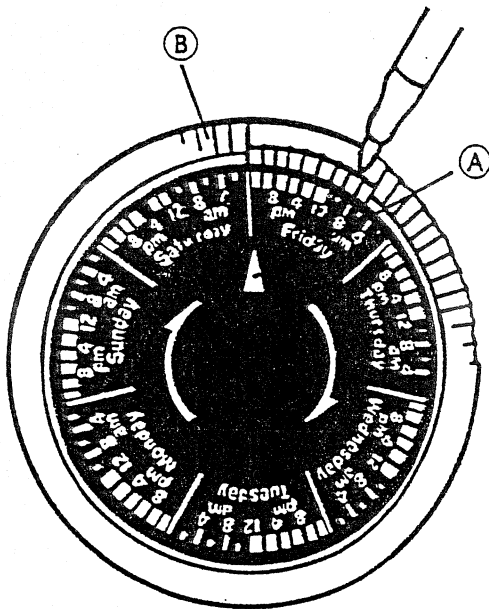

HEATER BY-PASS SWITCH

(All Horizons and Spectrum 155 only)

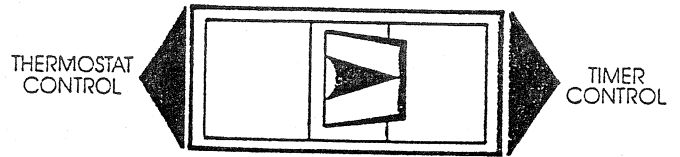

In this position the time clock has control and will start and stop the heating cycle as determined by the settings of the HEATING time clock lugs. The maximum water temperature is controlled by the thermostat setting.

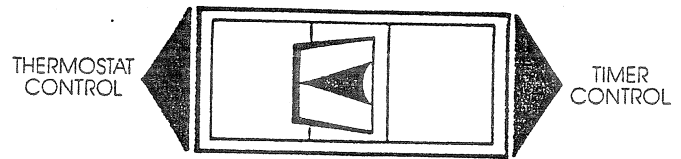

In this position the heating cycle will be continuous, controlled only by the setting of the thermostat. The heater will start and stop as required to maintain the desired temperature. This position is ideal for freeze protection. With the thermostat set at the FREEZE position, the heater will automatically cycle to maintain a water temperature of approximately 50 degrees. The time clock settings are not disturbed and timed cycles will begin again when this switch is returned to the TIMER CONTROL position.

With the thermostat in the OFF position, move the Main Power Switch to the ON position. The Pump and/or the Air Blower will start in one of the modes as described under spa side control functions.

IMPORTANT NOTE: It is very important that the Pump High Speed be operated for several minutes to assure that ALL air has been removed (bled) from the system. Only after full water flow has been established should the Thermostat be turned on.

START-UP PROCEDURES

First, follow recommendations for site location and electrical connection. **DO NOT PLUG IN UNIT** at this time. Fill spa with water to water line mark on weir door.

The water level must be measured with no one in the spa. The space from the water to the top lip of the spa allows for the water to rise as people enter the spa without it overflowing. **Operating the spa when the water level is low can damage the pump and heater and could cause a fire.**

Careful attention must be paid to filling with water and bleeding air from the Equipment Pak every time the spa is drained.

1. Turn OFF all electrical power to the Equipment Pak.
2. Turn the thermostat to the OFF position.
3. Open both slide valves to allow water to flow into the Equipment Pak and plumbing system.
4. Check all plumbing connections for leaks.
5. Apply electrical power to the Equipment Pak at this time.
6. Push reset button.

7. Select Hydro Jet mode (#3; turn on comfort timer on Horizon models); let the system run on this mode for a few minutes to bleed air out of the plumbing system. If the system does not prime after 4 minutes of running, turn the system off and contact your dealer. **DO NOT RUN DRY** for extended periods or you **WILL** permanently damage the pump.
8. Refer to the control operating instructions and Timer sheet.

NOTE: The Equipment Module must never be operated without water in the spa, serious damage to the heater and/or pump could result.

COMFORT TIME

(Horizon 211, 244, 228, 229)

The 30-minute comfort timer is located on the control panel of selected Horizon models. To make the spa operate beyond mode #1 (low heat and filter) the comfort timer must be turned on. Set it to the desired time you will use your spa. It can run from one to 30 minutes. If you choose to leave the spa earlier, you may turn the timer off by hand (counterclockwise). Otherwise, it will shut itself off, and return the spa to its' timer functions.

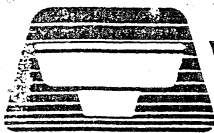

OPERATING INSTRUCTIONS

SPA SIDE CONTROL FUNCTIONS

- (A) **Function Air Button**
Controls the operation of the equipment as described under the spa side control section.
- (B) **Ready Light**
Lights when the desired water temperature has been reached.
- (C) **Thermostat**
Controls the Heater over a range of approximately 50 degrees to 105 degrees. Voltage and altitude, as well as movement during transporting, may affect the accuracy of your thermostat. Contact your dealer if your spa does not heat properly.
- (D) **Heater Light**
Lights when the Heater is on.
- (E) **Freeze**
Maintains water temperature at approximately 50° F.
- (F) **Jets Light**
When the High Speed jets are ON.
- (G) **Blower Light**
Lights when the Air/Blower is ON.
- (H) **Light Air Button**
Switches pedestal mood light (Horizon Only) and underwater light off and on.
- (I) **Silent Air Controls**
Allows air into jets, for adjustable vigorous water action.
- (J) **Comfort Timer (Horizon Only)**
Must be turned on to operate high speed functions. Returns spa to timer functions after 30 minutes. (Please note additional information on page 11).

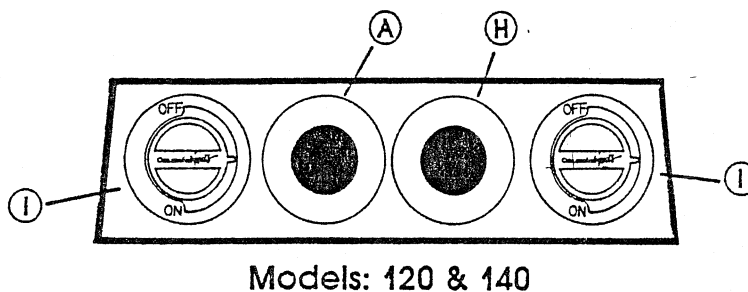
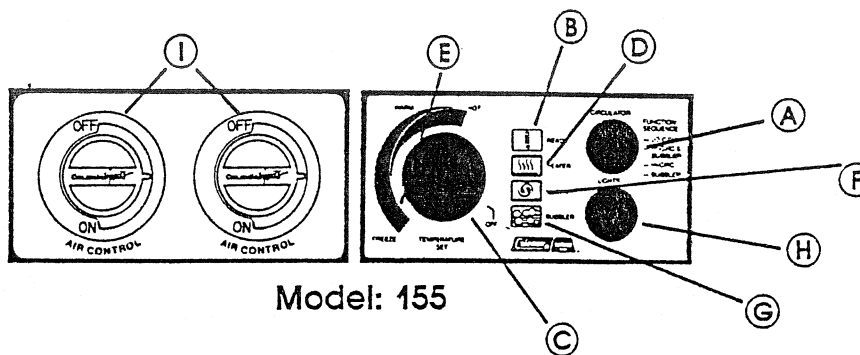
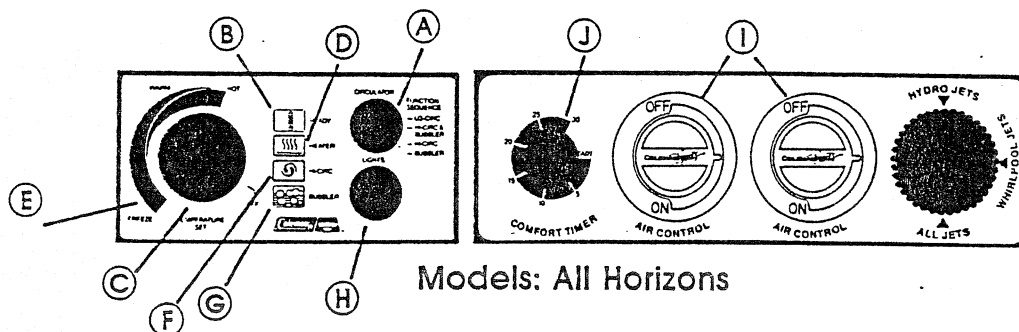

OPERATING INSTRUCTIONS

An air-activated control center is mounted on the lip of the spa for your safety and ease of operation. Each time the control function button is depressed, the switching mechanism will advance to the next Mode in the continuous sequence.

120 VOLT OPERATION

- MODE 1** Pump runs in **LOW** speed for filtration and Heater will operate as determined by thermostat setting. Heater and circulation time clock switches affect this mode only.
- MODE 2** Pump runs in **HIGH** speed for maximum hydro jet action. Air Blower operates aeration system. **Heater will not operate.**
- MODE 3** Pump runs in **HIGH** speed for jet action only. **Heater will not operate.**
- MODE 4** Air Blower operates aeration system only. **Heater will not operate.**

The indicator lights on the control center will sequence with each mode to display which mode is in operation (all Horizons & 155 only).

240 VOLT OPERATION

- MODE 1** Pump runs in **LOW** speed for filtration and Heater will operate as determined by thermostat setting. Heater and circulation time clocks switches affect this mode only.
- MODE 2** Pump runs in **HIGH** speed for maximum hydro jet action. Air Blower operates in High speed for maximum aeration system. Heater will cycle ON and OFF as determined by thermostat setting.
- MODE 3** Pump runs in **HIGH** speed for continued hydro jet action. Heater will cycle ON and OFF as determined by thermostat setting. Air Blower will not operate.
- MODE 4** Air Blower operates in low speed, for gentle operation. **Heater will not operate.** The indicator lights on the control center will sequence with each mode to display which mode is in operation.

The underwater light can be controlled by depressing the "light" function button also located on the spa side control.

For optimum performance and long-lasting equipment life, pause briefly (one to two seconds) between push button selections.

HYDRO-MASSAGE JETS

The level of jet action is determined by the amount of air entering the Hydro-Massage Jets (should be closed when heating). The Air Mixture Controls, located on the lip of the spa, establishes this level by increasing or decreasing the air to the jets.

The Hydro-Massage Jets, which are adjustable and directional, return water into the spa from the equipment. A turbulent flow of water mixed with air will provide a concentrated body massage. The flow of each jet can be adjusted by turning the knurled eyeball clockwise and counterclockwise.

AIR MIXTURE CONTROLS

The level of jet action is determined by the amount of air entering the hydro-massage (and whirlpool) jets (should be closed when heating). The air mixture controls, located next to the spa side controls, establishes this level by increasing or decreasing the air to the jets.

JET SELECTOR KNOB

(Horizon Only)

Enables you to choose one of 3 jet settings, 1—Hydro-Massage Jets, 2—Whirlpool Jets, 3—All Jets.

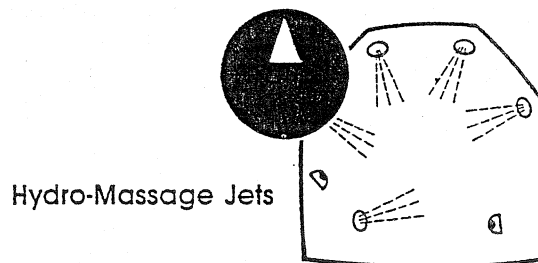

Hydro-Massage Jets

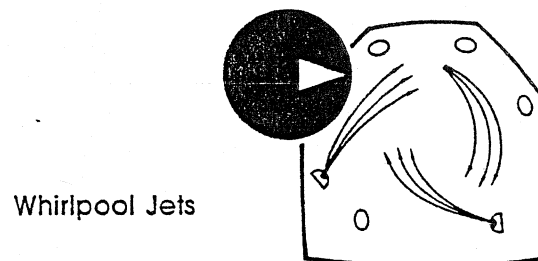

Whirlpool Jets

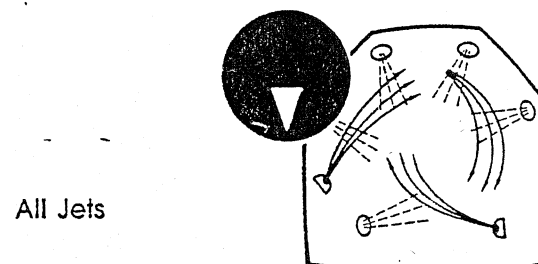

All Jets



OPERATING INSTRUCTIONS

SETTING THE TEMPERATURE

The thermostat will control the electric Heater in Mode 1, 2 and 3 when wired for 240 volt, and only in Mode 1 when wired for 120 volt operation.

The thermostat adjustment knob on the Horizon models and 155 is located on the spa side control panel. To set the thermostat initially, rotate the knob to the center of the hot range. The thermostat control knob for the 120 and 140 is located in the equipment box. Open door, move knob to hot range, close door, and heating mode will start.

This setting will cause the water temperature to rise to 95 to 100 degrees F. **Do NOT expect to feel hot water coming from the jets!** Turning the thermostat control to high will not heat the spa faster. It only controls the maximum temperature of the spa water.

Your spa will heat approximately 3 degrees per hour when wired for 120 volt and 8 to 10 degrees per hour when wired for 240 volts.*

*Spa Thermal Cover installed. Heating times are approximate.

If the water temperature reaches a level higher than you wish, turn the thermostat knob back to a lower setting. The spa's water temperature will stabilize after a while. When the water temperature falls below the temperature set on the thermostat, the heater and preset temperature pump will again cycle ON and OFF as needed to maintain preset temperature.

The length of time it takes the water to reach the desired temperature depends upon several factors: water temperature at start, ambient air temperature, spa gallonage, relative humidity, type and insulative qualities of the spa cover and constancy of electric power applied. Also be aware that prolonged use of the Air Blower and

hydro jets when using the spa will have a significant cooling effect on the water.

A spa cover will help control heat loss from the water's surface. It will also improve the spa heater's efficiency if you keep the spa cover in place while heating the water.

HELPFUL HINTS

Choose the desired control function using the air-activated button. Each time the button is pressed, the system advances to the next mode in sequence. Select the appropriate mode, relax and enjoy. When you are through, return the system to the heat/low pump mode, close air control valves, and replace cover.

Normal unattended operation of the spa is with the Equipment Pak in the heat/low pump mode. Water temperature is automatically maintained by the properly set (through trial-and-error and personal preference) thermostatically controlled heater and/or time clock setting. **At no time should the heater be allowed to heat the spa water above 104 degrees F.**

The air blower should be used only when people are in the spa to minimize heat loss and prevent chemical dissipation.

DO NOT OVERFILL THE SPA. IF THE ADDED VOLUME OF PEOPLE USING THE SPA RAISES WATER ABOVE THE RECOMMENDED LEVEL (6" BELOW LIP), DRAIN EXCESS WATER OR SEVERE EQUIPMENT PAK DAMAGE MAY RESULT. THE SPA WILL NOT OPERATE WITH DOOR OPEN.

Keep Equipment panel door securely closed to prevent possible shock or unauthorized adjustment.

COMFORT TIMER

The 30-minute comfort timer is provided to allow you to set the operating time for the Whirlpool/Hydro-Jets and aeration systems. The timer will automatically return the spa to the heating and filtration settings on the time clocks.

MAINTENANCE

SPA CABINET CARE

Your custom spa cabinet is made from quality handcrafted redwood. It has been coated with a seal and stain prior to spa assembly to preserve its appearance and help prevent weathering. Further wood protection requirements depend on spa location (indoors or out, sun, shade, etc.), and local climate conditions. Re-treat with an appropriate product recommended by your authorized dealer when necessary.

Cleaning the spa cabinet: Rinse dirt and dust regularly with clear water. To remove stubborn dirt, grime, and mild discoloration, wash with a mild detergent and warm water.

Restoring the wood's color: To restore the wood's color, scrub with a bristle brush and a solution of one cup trisodium phosphate (TSP) per gallon of warm water. Rinse with clear water. Repeat if the discoloration persists, and then apply a solution of 4 ounces oxalic acid crystals dissolved in one gallon of warm water. When the wood dries, rinse with clear water. More than one application may be necessary if discoloration is severe. **CAUTION:** Oxalic acid is poisonous, but not dangerous if precautions are taken. Wear rubber gloves. Avoid contact with skin or eyes. Read the directions carefully.

DRAINING SPA AND AIR CHANNEL

The water level in the spa must be kept at its normal level water line mark. Note: evaporation and splashing will cause the water level to drop.

Concentrations of impurities from evaporation, body oils, perfumes, and winds, etc., accumulate in the spa and cannot be filtered out. Consequently, it is necessary to drain your spa and refill it with fresh water every six to eight weeks or more often, depending on the amount of use.

To drain the spa, first switch the Equipment Pak to the standby mode and unplug the cord. If your spa is wired for 240 volt operation, turn circuit breaker off. Then attach a garden hose to the spa drain faucet and open the valve. **Do not use the pump to drain the spa.**

After draining the spa using the draw hose in the equipment compartment (open ball valve), clean the spa shell, skimmer and filter.

WATER TESTING AND CHEMICAL TREATMENT

Water chemistry is critical in a spa system - much more so than in an ordinary swimming pool. The combination of high temperature and small volume of water means that the chemical

balance must be watched carefully, which is why a chemical start up kit should be purchased from your Coleman Spas dealer. The instructions should be followed routinely; ignoring them may damage or corrode your support system equipment. Keep your chlorine residual at 1.0 to 2.0 parts per million. **Chlorine tests should be done daily with your test kit.**

Note: On Horizon models, turning on the Comfort Timer after adding chemicals is an excellent method for dispersing them throughout the spa water.

The pH balance should be maintained between 7.2 and 7.6, and is adjusted by the addition of pH up or pH down. We do not recommend the use of muriatic acid in your spa because of its corrosive effects on the nonporous surface of your spa and its metal parts. If you must use acid to correct the pH, use only the dry type and dissolve it in water prior to adding it to the water in the spa.

CLEANING

Your spa shell is formed by two layers of plastic material. The smooth top surface is made of tough long-lasting acrylic and contains concentrated color. This layer is supported by a substantial thickness of fiberglass-reinforced polyester resin. A chemical reaction occurs during manufacture that bonds these layers permanently into a hard, strong substance. A minimum amount of care and cleaning will keep your spa looking new for years.

To clean your spa, use a mild, non-abrasive liquid detergent, isopropyl alcohol, or commercially prepared spa cleaner. **Do not use abrasive cleaners.** Check with your dealer for approved cleaning materials, such as Lime-Away™.

You can protect and restore the gloss to a dulled surface by using a product designed specifically for use on acrylic finishes, such as an acrylic polish.

Use a spa cleaner for residue and lime buildup at the water level of the spa surface. This can be applied to the acrylic surface with a soft cloth and wiped clean. Use small amounts to avoid polluting spa water. It may be necessary to lower the water level 2 to 3 inches before cleaning if heavily soiled at the waterline.

FILTER MAINTENANCE

The removable filter cartridge is located in the filter canister behind the skimmer. The filter should be inspected at least monthly during normal use, and more often when spa use is heavy.

Keep the filter clean! A clogged filter decreases both performance and water quality.

cont.

MAINTENANCE

Filter maintenance cont.

To clean the filter, simply follow these steps:
(Note: it is not necessary to drain the spa.)

1. Turn power switch to the standby position.
2. Remove round filter lid on top of spa.
3. Remove strainer basket.
4. Remove filter cartridge from the filter cannister by grasping the handle on top, unscrewing it counterclockwise, and lifting out.
5. Soak and hose out filter cartridge, unless replacing with new cartridge.
6. Place filter cartridge back into filter cannister, and screw back in clockwise with handle until snug. **Do not overtighten.**
7. Replace round filter lid.
8. Turn the power switch to the ON position.

In addition to performing normal filter maintenance, it will be necessary to occasionally remove oils that coat the filter reducing filter flow. To remove these oils, soak the cartridge in a plastic pail containing a commercial filter cleaning solution (available from your Coleman Spa dealer or most pool supply stores). Follow the manufacturer's instructions for use.

We suggest that you replace your filter cartridge yearly to maintain optimum performance.

WINTERIZING

In cold climates where freezing temperatures occur, special care is required to prevent the possibility of damage to the spa and equipment due to freezing.

If you plan on using your spa during cold months, be sure your pump and heater are in good working order. The spa shell has been insulated to provide efficient operation in cold weather areas.

SPECIAL NOTE: IF YOU DO NOT INTEND TO USE YOUR SPA DURING THE WINTER MONTHS AND THERE IS DANGER OF FREEZING, THE SPA MUST BE WINTERIZED! YOU MUST DO THE FOLLOWING:

1. Shut off all electrical power to the portable spa.
2. Drain spa of all water. If you cannot draw off all of the water (especially from hoses) R.V. anti-freeze should be added to the remaining water. If anti-freeze is used, it should be an inhibitor Propylene Glycol such as Dow Frost available through Dow Chemical Distributors.
3. Be sure to drain all drain hoses.
4. The filter should be drained, and cartridge removed and cleaned.
5. Check to see that there is no water in the heater element chamber and air blower elbow.
6. Clean your spa as per previous maintenance instructions.
7. Cover your spa with a waterproof, water-shedding, impenetrable cover.

SERVICING PEDESTAL MOOD LIGHTING LIGHT BULBS: Pop out the clear lense with a small screwdriver. To remove the light bulb from the socket, push in by hand, and turn counterclockwise 1/4 turn and remove from socket. Replace with a 12 volt, 1 watt light bulb, available at your local auto parts store.

IMPORTANT

THE USE OF LIGHT BULBS RATED OVER 1 WATT WILL CAUSE THE PERIMETER LIGHTING SYSTEM TO FAIL.

P R O B L E M S O L V I N G G U I D E

PROBLEM	USUAL CAUSE	SOLUTION
1. System not operating.	<ul style="list-style-type: none"> A. Equipment panel door off or out of alignment. B. House circuit breaker tripped or in OFF position. C. GFCI on face of spa pak tripped. D. Power cord not connected to outlet. 	<ul style="list-style-type: none"> A. Put equipment panel door in place. B. Reset circuit breaker on home breaker panel C. Push GFCI reset on. D. Connect power cord to outlet.
2. Heater not functioning.	<ul style="list-style-type: none"> A. Heater mode not selected. B. No power to heater. C. Thermostat set lower than water temperature. D. High temperature safety switch tripped. E. Heater relay not operating. F. Heater element failure. 	<ul style="list-style-type: none"> A. Select HEATER/FILTER mode #1. B. Check house circuit breaker and GFCI. Be sure equipment cabinet door is in place. C. Turn to desired temperature. D. Push reset button on heater after water has cooled; contact dealer if switch continues to trip. E. Contact dealer. F. Contact dealer.
3. Water not clean.	<ul style="list-style-type: none"> A. Clogged or blocked floor suction or skimmer. B. Filter clogged (dirty). C. Poor water chemistry. D. Insufficient filtering time. E. Improper maintenance. F. High content of solids in water. 	<ul style="list-style-type: none"> A. Clean floor suction/skimmer. B. Clean or replace. C. See "Chemical Treatment" section. D. Run filtration mode longer. E. See maintenance section. F. Use clarifier or drain and refill spa.
4. Abnormal water usage.	<ul style="list-style-type: none"> A. Leak in system plumbing. B. Excessive evaporation and/or splashing. 	<ul style="list-style-type: none"> A. Repair leak. B. Use spa cover; lower thermostat setting.

P R O B L E M S O L V I N G G U I D E

PROBLEM	USUAL CAUSE	SOLUTION
5. Low water flow from jets.	<ul style="list-style-type: none"> A. Operating in FILTER mode #4. B. Clogged or blocked suction or skimmer. C. Dirty filter. D. Suction or discharge line partially plugged. E. Slide Shutoff valves partially or fully closed. F. Pump running at sub-normal speed. G. Worn or damaged pump seal. 	<ul style="list-style-type: none"> A. Select Hydro Jet mode #2 or #3 for maximum action. B. Clean floor suction/skimmer. C. Clean or replace. D. Contact dealer. E. Open both slice valves. F. Contact dealer. G. Contact dealer.
6. No water flow from jets.	<ul style="list-style-type: none"> A. Unit not plugged in. B. Selector switch in OFF. C. House circuit breaker tripped, no power to system. D. Equipment panel door open or not in place. E. Slice valves closed. F. GFCI tripped. G. Faulty pump or motor. 	<ul style="list-style-type: none"> A. Plug unit in. B. Select other function. C. Reset circuit breaker at home panel. D. Put equipment panel door in place. E. Open slice valves. F. Reset GFCI. G. Contact dealer.
7. Noisy pump and motor.	<ul style="list-style-type: none"> A. Clogged floor suction or skimmer. B. Leakage of air into suction line. C. Low water level. D. Damaged or worn motor bearings. E. Impeller rubbing inside case. F. Debris inside pump. G. Intake slice valve closed. 	<ul style="list-style-type: none"> A. Clean floor suction/skimmer. B. Locate and repair leaks. C. Add water to normal water level (6" below lip). D. Contact dealer. E. Contact dealer. F. Contact dealer. G. Open both slice valves.
8. Water leakage at pump shaft (rotating connection between pump and motor).	<ul style="list-style-type: none"> A. Worn or damaged pump seal. 	<ul style="list-style-type: none"> A. Contact dealer.

P R O B L E M S O L V I N G G U I D E

PROBLEM	USUAL CAUSE	SOLUTION
9. Motor will not operate.	A. Main power switch in STANDBY.	A. Turn power switch ON.
	B. House circuit breaker tripped or in OFF position.	B. Reset circuit breaker.
	C. Equipment panel door not in place.	C. Put equipment panel door in place.
	D. GFCI tripped.	D. Reset GFCI.
	E. Improper or defective wiring.	E. Contact dealer.
	F. High temperature safety switch tripped.	F. Reset button on heater after water has cooled; contact dealer if switch continues to trip.
	G. Inadequate electrical supply.	G. Contact dealer.
	H. Locked shaft or impeller.	H. Contact dealer.
	I. Motor windings burned out.	I. Contact dealer.
	J. Defective starting switch inside motor.	J. Contact dealer.
	K. Motor overload condition.	K. Let cool for one hour. Motor overload will reset; if problem persists contact dealer.
	L. Mode switch failure.	L. Contact dealer.
	10. Blower motor will not operate.	A. OFF mode selected.
B. House or panel mounted circuit breaker tripped or in OFF position.		B. Reset circuit breaker on Equipment Pak face on Home circuit breaker panel.
C. Equipment panel door not in place.		C. Put equipment panel door in place.
D. GFCI tripped.		D. Reset GFCI.
E. Improper or defective wiring.		E. Contact dealer.
F. Inadequate electrical supply.		F. Contact dealer.
G. Motor windings burned out.		G. Contact dealer.
H. Defective starting switch inside motor.		H. Contact dealer.
I. Brushes worn.		I. Contact dealer.
J. Selector switch failure.		J. Contact dealer.
K. Relay failure.		K. Contact dealer.



LIMITED WARRANTY SUMMARY

(Please see the Warranty Card included with your product for complete warranty information.)

Coleman Spas, Inc. provides a limited warranty to our customers. It applies to the spa structure, surface, most plumbing, the pump, filter, heater, blower, controls and underwater lights.

The warranty has limitations. These include transportation charges, removal or installation charges for replacement caused by improper maintenance, improper installation, misuse, abuse, accident, fire, normal wear and tear or improper water maintenance. Unauthorized modifications of the spa will void the warranty.

Coleman stresses that prospective consumers carefully read the complete warranty to fully understand its benefits and limitations.

SPA SOAKING GUIDELINES.

1. Persons with heart disease, diabetes, high or low blood pressure or any serious illness, and pregnant women should not enter a spa without prior consultation with their doctor.
2. People with skin, ear, genital or other body infections, open sores or wounds should not use the spa because of the possibility of spreading infection.
3. Before entering, look at the water in your spa. If there is cloudiness or foaming, or if a strong chlorine smell is present, the water needs treatment. Soaking in such water greatly increases your chances of getting a skin rash (pseudomonas). Be sure to maintain the water properly. Ask your Authorized Coleman Spas Dealer for guidance.
4. Shower with soap and water before and after using the spa. Showering before use washes away many of the common skin bacteria, and removes lotions, deodorants, creams, etc. Perspiration and lotions will reduce the effectiveness of the disinfectant and lessen the ability of the filter to work efficiently.
5. Enter the spa slowly and cautiously. Be careful of your footing, and allow your body to gradually get used to the water temperature. Leave slowly as well, because your leg muscles may be sufficiently relaxed to make you a bit unsteady, and you may become lightheaded.
6. Soaking for too long makes some people nauseous, dizzy, lightheaded or faint. **DON'T SOAK FOR MORE THAN 15 MINUTES AT ONE SITTING IN 104°F (40°C) WATER.** If you wish to soak for a longer period of time in high temperatures, leave the spa after 15 minutes, shower, cool down and then return for another brief stay. In lower temperatures (e.g. 98.6°F - normal body temperature) most people can comfortably and safely soak for longer periods at one sitting. If you have any questions about what's right for you and your family, consult with your doctor.
7. Keep an accurate thermometer in the spa at all times to monitor the water temperature. Be sure you check the water temperature before and while in the spa.
8. Never use the spa while under the influence of alcohol.
9. With any drug or medication, consult with your doctor about potential harmful effects from combined use of the drug and hot water soaking.
10. Never use the spa when you are alone, for safety's sake.
11. Never allow children to use the spa unsupervised.

COLEMAN *Spas*™
Coleman Spas

25805 South Arizona Avenue
Chandler, Arizona 85248

© 1988 COLEMAN SPAS, INC.

