

Coleman Spas 500 Series



By MAAX

Owner's Manual

Copyrights and Trademarks

©Copyright 2001 MAAX Spas (Arizona), Inc.. All rights reserved. No parts of this publication may be reproduced, stored in a retrieval system, or transmitted, in any form or by any means (electronic, mechanical, photocopying, recording or otherwise), without prior written permission.

Horizon®, Spectrum®, California Cooperage®, Journey™, Powerworks®, Comfort Collar™, Thermo-Lock®, Foot Relief Zone™, and GRIP® are registered trademarks of the Maax Spas (Arizona), Inc.

Disclaimer:

The information in this manual is accurate to the best of MAAX Spas (Arizona), Inc.'s knowledge. However, MAAX Spas (Arizona), Inc. assumes no responsibility for errors or omissions. Nor is any liability assumed for damages resulting from use of the information contained herein.

Congratulations on your purchase of a Coleman Spa. Your Owner's Manual provides installation, operation and maintenance instructions. Please review it and keep it for future reference.

Save These Instructions

Owner's Record Information

Date Purchased _____

Purchased From _____

Phone Number _____

Installed By _____

Serial Number _____ Model _____

Limited Warranty Summary

Please see the Warranty Card included with your product for complete warranty information.

Please note that in order to perform prompt warranty service it is extremely important that you return your warranty card complete with model and serial number to MAAX Spas (Arizona), Inc. immediately upon installation.

MAAX Spas (Arizona), Inc. provides a limited warranty to our customers. It applies to the spa structure, surface, most plumbing, the pump, heater, blower, and controls.

The warranty has limitations. These include improper maintenance, improper installation, misuse, abuse, accident, fire, normal wear and tear or improper water maintenance. Unauthorized modifications of the spa may void the warranty. Replacement costs associated with transportation, removal, and reinstallation are the sole responsibility of the spa owner.

This manual refers to only year 2001 model spas. MAAX Spas (Arizona), Inc. reserves the right to make changes in design or material of its products at any time without incurring liability. This limited warranty applies to the first retail purchaser and terminates upon any transfer of ownership.

IMPORTANT SAFETY INSTRUCTIONS

When installing and using this electrical equipment, basic safety precautions should always be followed, including the following:

(1) **READ AND FOLLOW ALL INSTRUCTIONS**

- (2) A green colored terminal or a terminal marked G, GR, Ground, Grounding, or the international symbol*  is located inside the supply terminal box or compartment. To reduce the risk of electric shock, this terminal must be connected to the grounding means provided in the electric supply service panel with a continuous copper wire equivalent in size to the circuit conductors supplying this equipment.

*IEC Publication 417, Symbol 5019.

- (3) At least two lugs marked "BONDING LUGS" are provided on the external surface or on the inside of the supply terminal box or compartment. To reduce the risk of electric shock, connect the local common bonding grid in the area of the hot tub or spa to these terminals with an insulated or bare copper conductor not smaller than No. 6 AWG.
- (4) All field-installed metal components such as rails, ladders, drains or similar hardware within 5 ft of the spa or hot tub shall be bonded to the equipment grounding bus with copper conductors not smaller than No. 6 AWG.

(5) **SAVE THESE INSTRUCTIONS.**

WARNING: Children should not use spas or hot tubs without adult supervision

and

AVERTISSEMENT: Ne pas laisser les enfants utiliser une cuve de relaxation sans surveillance

WARNING: Do not use spas or hot tubs unless all suction guards are installed to prevent body and hair entrapment

and

AVERTISSEMENT: Pour éviter que les cheveux ou une partie du corps puissent être aspirés, ne pas utiliser une cuve de relaxation si les grilles de prise d'aspiration ne sont pas toutes en place

WARNING: People using medications and/or having an adverse medical history should consult a physician before using a spa or hot tub

AVERTISSEMENT: Les personnes qui prennent des médicaments ou ont des problèmes de santé devraient consulter un médecin avant d'utiliser une cuve de relaxation

WARNING: People with infectious diseases should not use a spa or hot tub

AVERTISSEMENT: Les personnes atteintes de maladies infectieuses ne devraient pas utiliser une cuve de relaxation

WARNING: To avoid injury exercise care when entering or exiting the spa or hot tub

AVERTISSEMENT: Pour éviter des blessures, user de prudence en entrant dans une cuve de relaxation et en sortant

WARNING: Do not use drugs or alcohol before or during the use of a spa or hot tub to avoid unconsciousness and possible drowning

AVERTISSEMENT: Pour éviter l'évanouissement et la noyade éventuelle, ne prendre ni drogue ni alcool avant d'utiliser une cuve de relaxation ni quand on s'y trouve

WARNING: Pregnant or possibly pregnant women should consult a physician before using a spa or hot tub

and

AVERTISSEMENT: Les femmes enceintes, que leur grossesse soit confirmée ou non, devraient consulter un médecin avant d'utiliser une cuve de relaxation

Warnings

WARNING: Water temperature in excess of 100°F (38° C) may be injurious to your health and

AVERTISSEMENT: Il peut être dangereux pour la santé de se plonger dans de l'eau à plus de 38° C

WARNING: Before entering the spa or hot tub measure the water temperature with an accurate thermometer and

AVERTISSEMENT: Avant d'utiliser une cuve de relaxation mesurer la température de l'eau à l'aide d'un thermomètre précis

WARNING: Do not use a spa or hot tub immediately following strenuous exercise and

AVERTISSEMENT: Ne pas utiliser une cuve de relaxation immédiatement après un exercice fatigant

WARNING: Prolonged immersion in a spa or hot tub may be injurious to your health and

AVERTISSEMENT: L'utilisation prolongée d'une cuve de relaxation peut être dangereuse pour la santé

WARNING: Do not permit electric appliances (such as a light, telephone, radio, or television) within 1.5m of the spa or hot tub and

AVERTISSEMENT: Ne pas placer d'appareil électrique (luminaire, téléphone, radio, téléviseur, etc) à moins de 1.5, de cette cuve de relaxation

WARNING: Maintain water chemistry in accordance with manufacturer's instruction and

AVERTISSEMENT: La teneur de l'eau en matières dissoutes doit être conforme aux directives du fabricant.

WARNING: The use of alcohol or drugs can greatly increase the risk of fatal hyperthermia in hot tubs and spas and

AVERTISSEMENT: La consommation d'alcool ou de drogue augmente considérablement les risques d'hyperthermie mortelle dans une cuve de relaxation.

HYPERTHERMIA

The causes, symptoms, and effects of hyperthermia may be described as follows. Hyperthermia occurs when the internal temperature of the body reaches a level several degrees above the normal body temperature of 98.6°F (37° C). The symptoms of hyperthermia include drowsiness, lethargy, and an increase in the internal temperature of the body. The effects of hyperthermia include

- (a) unawareness of impending hazard;
- (b) failure to perceive heat;
- (c) failure to recognize the need to exit spas;
- (d) physical inability to exit spa;
- (e) fetal damage in pregnant women; and
- (f) unconsciousness and danger of drowning.

Contents

Important Safety Instructions	2	Jets, Air Controls and Air Injectors ...	16
Do's and Don'ts	3	Jets	16
Hyprethermia	3	Air Controls	16
Spa System Components	4	Maintenance	16
Spa Components	5	Water Chemistry	16
Spa Installation	6	Sanitizing	16
Site and Positioning	6	pH Level	16
Outdoor Installation	6	pH Sensor Operation	17
Indoor Installation	6	Water Maintenance With the	
Electrical Information	6	Powerworks® Ozonator	17
Ground-Fault Circuit-Interrupter	6	Sanitizing With Ozone	17
Important Safety Instructions	7	Specialty Chemicals	17
Installation Options	7	Hot Water Guide	18
Start Up Procedures	8	Spa Cabinet Care	19
Operating Instructions	9	Draining Spa	19
Powerworks 500 Series - 506, 508SLII, 550, 555		Drain Access	20
Control System	9	Priming Spa	20
User's Pads	9	Spa Surface Care and Cleaning	20
Temperature Controls	9	Filter Maintenance	20
Time and Filtration Cycles	10	Winterizing	21
Preset Filter Cycles	10	Light Bulbs	21
Changing Filter Cycles	10	Problem Solving Guide	22
Ozone Operation	11	Spa Soaking Guidelines	24
Powerworks 500 Series - 502, 508SLI		Technical Specifications	24
Control System	12	500 System Wiring Diagram 502, 508SLI ...	25
User's Pads	12	500 System Wiring Diagram 506, 508SLII, 550, 555 ...	26
Temperature Controls	12	Safety Sign	27
Time and Filtration Cycles	13		
Preset Filter Cycles	13		
Changing Filter Cycles	13		
Ozone Operation	14		
Safety Features	15		
Automatic Time Outs	15		
Error Messages	15		

IMPORTANT SAFETY INSTRUCTIONS

**Caution: Risk of electrical shock.
Read and follow all instructions.**

When installing and using this electrical equipment, basic safety precautions should always be followed, including the following:

1. READ AND FOLLOW ALL INSTRUCTIONS.

2. **Warning:** To reduce the risk of injury, do not permit children to use this product unless they are closely supervised at all times.
3. A wire connector is provided on this unit to connect a minimum No. 6 AWG (5.15 mm²) solid copper conductor between this unit and any metal equipment, metal enclosures of electrical equipment, metal water pipe, or conduit within 5 feet (1.5 m) of the unit.
4. **Danger:** Risk of Injury.
Never connect unit to a power supply with a load controller.

IMPORTANT SAFETY INSTRUCTIONS

5. **Danger:** Risk of Accidental Drowning. Extreme caution must be exercised to prevent unauthorized access by children. To avoid accidents, ensure that children cannot use this spa unless they are supervised at all times.
6. **Danger:** Risk of Injury. The suction fittings in this spa are sized to match the specific water flow created by the pump. Should the need arise to replace the suction fittings or the pump, be sure that the flow rates are compatible.
Never operate spa if the suction fittings are broken or missing. Never replace a suction fitting with one rated less than the flow rate marked on the original suction fitting.
7. **Danger:** Risk of Electrical Shock. Install at least

5 ft (1.5 m) from all metal surfaces. As an alternative, a spa may be installed within 5 feet of metal surfaces if each metal surface is permanently connected by a minimum No. 6 AWG (5.15 mm²) solid copper conductor attached to the wire connector on the terminal box that is provided for this purpose.

8. **Danger:** Risk of Electric Shock. Do not permit any electric appliance, such as a light, telephone, radio, or television, within 5 ft (1.5 m) of a spa.

A licensed electrician should make the final electrical connections.

The electrical supply for this product must include a suitably rated switch or circuit breaker to open all ungrounded supply conductors to comply with section 422-20 of the National Electrical Code ANSI/NFPA 70-1987. This disconnecting means must be readily accessible for operation but installed at least 5 ft. (1.5 m) from the spa as required to comply with local code requirements. All electrical connections should comply with article 680-D of the NEC.

Install to provide drainage of compartment for electrical components.

9. **Warning:** To reduce the risk of injury:
 - a) The water in a spa should never exceed 104°F (40°C) . Water temperatures between 100°F (38°C) and 104°F (40°C) are considered safe for a healthy adult. Lower water temperatures are recommended for young children and when spa use exceeds 10 minutes.
 - b) Since excessive water temperatures have a high potential for causing fetal damage during the early months of pregnancy, pregnant or possibly pregnant women should check with physician before entering spa, and limit spa water temperatures to 100°F (38°C).
 - c) Before entering a spa, the user should measure the water temperature with an accurate thermometer since the tolerance of water temperature-regulating devices varies.
 - d) The use of alcohol, drugs, or medication before or during spa use may lead to unconsciousness with the possibility of drowning.
 - e) Persons suffering from obesity or with a medical history of heart disease, low or high blood pressure, circulatory system problems,

or diabetes should consult a physician before using a spa.

- f) Persons using medication should consult a physician before using a spa since some medication may induce drowsiness while other medication may affect heart rate, blood pressure, and circulation.

10. **SAVE THESE INSTRUCTIONS.**

Do's and Don'ts

Do:

- Replace your cover immediately after use.
- Be aware of the dangers of a wet and slippery surface. Use caution when entering and exiting your spa.
- Have a **licensed electrician** make all final electrical connections.
- Keep your water chemistry correctly balanced. Untreated spa water will cause problems with your spa and equipment as well as being a health risk.
- Clean your filter monthly. (See filter maintenance pg. 20)
- Position your spa in such a way as to leave adequate room to access all sides for maintenance purposes.
- Use a bathing cap with long hair.
- Refer to information on hyperthermia on this page.
- Use only authorized spa care products for the best performance and to keep your water properly balanced for years of enjoyment.

Don't:

- Use the spa at 104°F (40°C) for long periods of time. Do refer to information on hyperthermia on this page.
- Use an extension cord to power your spa.
- Allow anyone to stand on the spa cover. It is not designed to support weight.
- Power the spa unless it is filled with water to the water level mark on the Weir door.
- Operate the pump for extended periods of time with the cover in place. Extended operation can

cause heat build-up and interfere with spa operation.

Hyperthermia

The causes, symptoms, and effects of hyperthermia may be described as follows: Hyperthermia occurs when the internal temperature of the body reaches a level several degrees above the normal body temperature of 98.6°F (37°C). The symptoms of hyperthermia include an increase in the internal temperature of the body, dizziness, lethargy, drowsiness, and fainting. The effects of hyperthermia include (1) failure to perceive heat, (2) failure to recognize the need to exit spa or hot tub, (3) unawareness of impending hazard, (4) fetal damage in pregnant women, (5) physical inability to exit the spa or hot tub, and (6) unconsciousness resulting in the danger of drowning.

Warning: The use of alcohol, drugs, or medication can greatly increase the risk of fatal hyperthermia.

Spa System Components

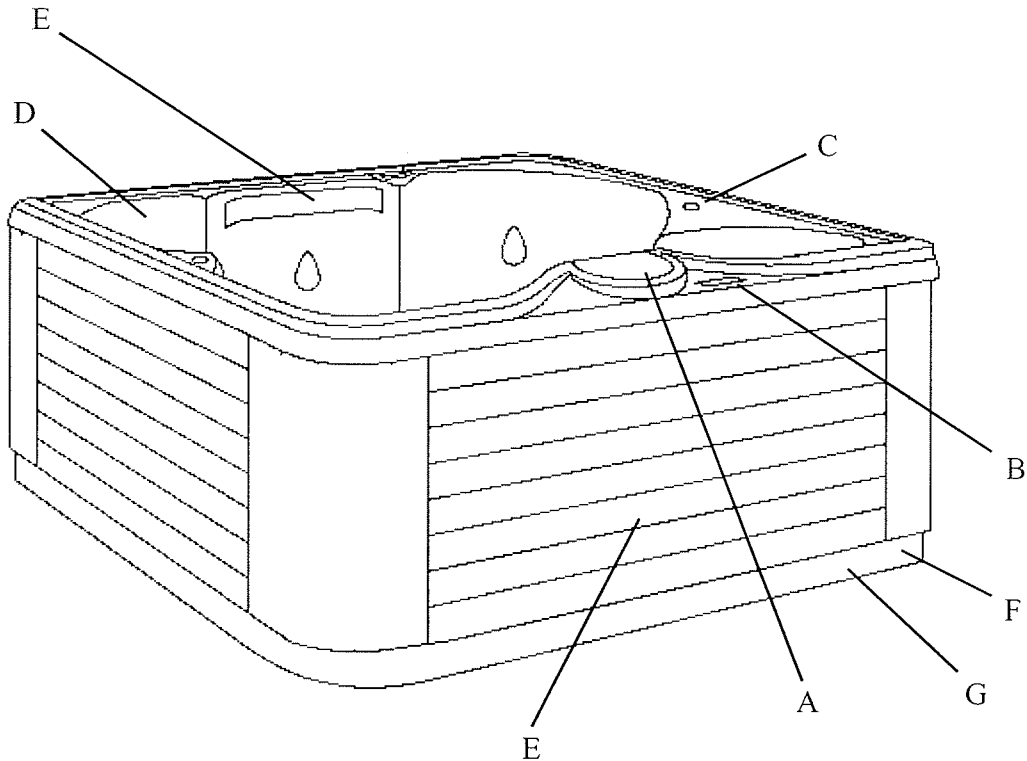

Spa System Components

- A. Filter Skimmer/Weir Door:** Removes floating debris from the water surface, provides a water return path to equipment, and houses water filter element.
- B. Topside Control Panel:** Used to control temperature setting, pump for jets and light.
- C. Air Controls:** Increases or decreases air entering the jets. Close during heating for maximum efficiency.
- D. Coleman Spas Diverta Jet:** Used to direct the flow from the whirlpool jet to the open seating area jets in the spa.
- E. Equipment Pack Service Panel (no user serviceable parts):** Spa support system consisting of one or two pumps, heater, and associated electrical controls (not shown).
- F. Drain Access (Adjacent to the equipment service panel):** Spa drain faucets.
- G. Manufacturer's Identification Label:** Contains identification information for warranty service.

Spa Components

Reference only. Equipment is not always as shown.

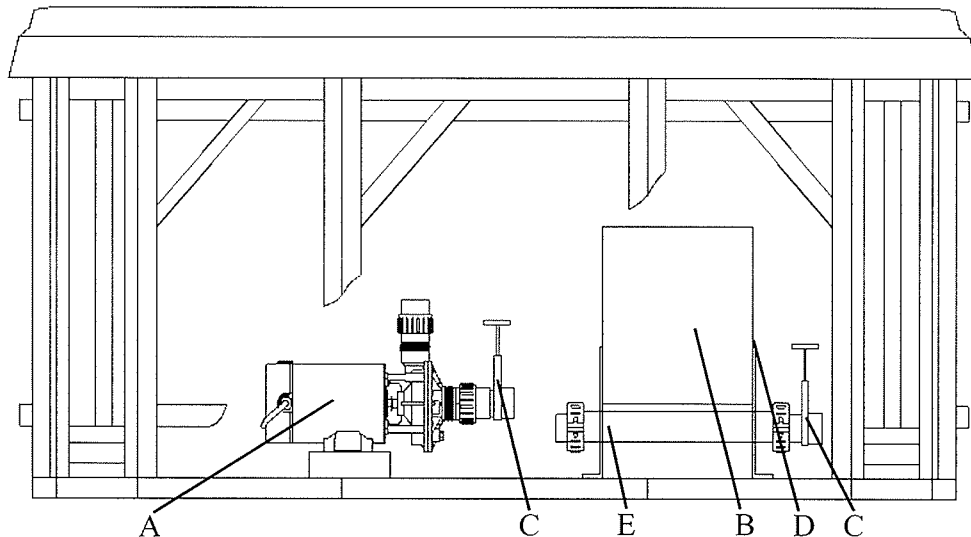

Note: No consumer serviceable parts. -Recommend that only an authorized service technician perform hot tub repair / service

- A. Pumps:** One pump on the Models 502SL and 508SLI, two pumps on Models 506SL, 508SLII, 550SL, and 555SL. Low speed for efficient water circulation during filtration and heating; high speed for maximum action of the jets. The pump functions are activated by topside controls. (Dual pump systems come with 1 dual speed pump and 1 single speed pump.)
- B. Warning and Installation Label:** Contains important safety information and installation instructions.
- C. Slice Valve:** Used to shut off water flow from the spa to the equipment while servicing. Quantity will vary depending on model. All should be open during normal operations.
- D. Electrical Connections:** The electrical plugs for the unit connect here. All existing connections should be intact.
- E. Heater Assembly:** Thermostatically controlled and equipped with an overheat safety shut-off.

Spa Installation

Danger: Risk of electrical shock. Install at least 5 feet from all metal surfaces.

The electrical supply for this product must include a suitably rated switch or circuit breaker to open all ungrounded supply conductors to comply with Section 422- 20 of the National Electrical Code, ANSI/NFPA70-1987. The disconnecting means must be readily accessible but installed at least 5 feet (1.5 meters) from the spa water. All electrical connections should comply with article 680-D of the NEC.

Site and Positioning

Locate the spa on solid, level foundation or flooring. Keep in mind the weight of the filled spa (in excess of 4,000 lbs. on some models). If you have any doubts about the load bearing ability of your chosen site, contact an architect, your building department or a building contractor. The entire perimeter of the spa cabinet and the spa bottom must be evenly supported.

If your spa is installed outdoors, we recommend that you provide a concrete pad for the spa to rest on (8ft.x8ft.x4" level pad). Failure to provide a level surface could structurally damage your spa and will void the warranty.

The spa must be installed to allow access for service and maintenance on all four sides; therefore, below grade level installation is not recommended.

Outdoor Installation

Keep the following additional factors in mind when installing your spa outdoors:

1. Local codes pertaining to fencing.
2. Local electrical and plumbing codes.
3. View from your house.
4. Wind direction.
5. Exposure to sunlight.
6. Location in regard to trees (falling leaves and shade).
7. Dressing and bathroom location.
8. Storage area for maintenance equipment and chemicals.
9. Location to facilitate adult supervision.

10. Landscaping and nighttime lighting.
11. Access to equipment cabinet panels.
12. Power supply location and foot traffic.

Indoor Installation

Keep the following additional factors in mind when installing your spa indoors:

1. Indoor spas promote high humidity, so a means of decreasing this humidity must be provided. This can be accomplished by using either ventilation fans or oversized de-humidifiers. Consult your dealer.
2. **Floor drains must be provided near the spa to drain off water which may cause walking hazards and /or water damage.**
3. Floor area should be flat and non-skid. No carpeting, ceramic tile is preferred.
4. Walls, ceilings, woodwork should be of materials capable of withstanding high humidity (redwood, cedar).
5. Be sure floor load bearing capacities are adequate to support the concentrated spa weight.
6. Spas should be double checked for leaks before installing to avoid possible water damage.
7. Indoor sunrooms are capable of maintaining high ambient temperatures which may effect the spa water temperature. It is **NOT** recommended that you operate your filter cycles for longer than 4 hours under these conditions.

Electrical Information

Caution: Risk of electrical shock. Read and follow all instructions.

Ground-Fault Circuit-Interrupter

A qualified licensed electrician shall connect the spa to a circuit protected by a GFCI. This is a requirement by the National Electric Code, article 680-42, and is also in compliance with Underwriter's Laboratories, Inc.

Important Safety Instructions

Prior to performing any service to the spa equipment, turn off all primary electrical power at the main circuit breaker or disconnect panel. All field electrical connections can be made by removing the front panel of the electrical control box. To gain access to the control box you must remove the exterior equipment access panel.

All electrical connections to this spa package must be accomplished by a qualified **licensed electrician** in accordance with the National Electrical Code and in accordance with local electrical codes in effect at the time of installation.

All connections should be made in accordance with the wiring diagram in the control box.

This equipment is designed to operate on 60Hz alternating current only, at 240 volts or no volts as required.

Connections should be made using copper conductors only. The connecting wire and circuit breakers or fuses must all be sized to accommodate the Total Ampere load as specified on the equipment label.

ALL UNIONS MUST BE HAND-TIGHT AND ALL SLICE VALVES MUST BE LOCKED IN THE "OPEN" POSITION BEFORE FILLING OR REFILLING THE SPA! RUN SPA AND CHECK FOR UNION LEAKS BEFORE REINSTALLING FRONT PANEL.

Installation Options

500 Series

The 500 Series Model 502SL is convertible to either 120 volt or 240 volt electrical service. All other models can **only** be connected to a 240 volt electrical service.

120 Volt Installation

Model:

- The 500 Series Model 502.

Electrical Requirements:

- 120 Volts, 60Hz, Single Phase, 30 amp. or *20 amp 3 wire service, (including ground.)

***20 Amp Option** (see J23 diagram on p8)

The heater can only be activated with the pump on low speed. Only the light can be operating at the same time without disabling the heater. See your authorized Coleman Spas dealer to select this option.

- 500 Series spas installed for 120 volt operation require a 3 wire, 30 amp., 120 volt subfeed in non-metallic pipe to the spa equipment compartment (line 1, neutral and ground). Refer to wiring diagram on page 25. A green colored terminal (or wire connector marked "G", or "GR", "Grounding") is provided in the control box. To reduce the risk of electrical shock, connect this terminal or connector to the grounding terminal of your electrical service or supply panel with a continuous green insulated copper wire equivalent to the circuit conductor supplying this equipment, but no smaller than No. 12 AWG. In addition, a second pressure wire connector is provided on the surface of the control box for bonding to local ground points. To reduce the risk of electrical shock, this connector should be bonded with a No. 6 AWG copper wire to any metal ladders, water pipes, or any metal within 5 feet of the spa. **Coleman recommends using copper wire for all electrical connections.**

240 Volt Installation

Permanently Connected

Model:

- The 500 Series models 506SL, 508SLI, 508SLII, 550SL, and 555SL must be connected to a 240-volt electric service. The model 502SL is convertible to either 120-volt or 240-volt, but comes factory wired for 240-volt service.

Electrical Requirements:

- 240 Volts, 60Hz, Single Phase, 50 amp. 4 wire service (including ground.)

***30 Amp Option** (see J23 diagram on p8)

The heater can only be activated with the pump on low speed. Only the light can be operating at the same time without disabling the heater. See your authorized Coleman Spas dealer to select this option.

Units to be operated at 240 volts must have all electrical connections made by a qualified electrician in accordance with the National Electric Code and in effect at the time of installation.

A hole can be drilled in the pedestal or base of the unit to bring the conduit to the equipment compartment.

- 500 Series spas installed for 240 volt operation require a 4 wire, 50 amp., 240 volt subfeed in non-metallic pipe to the spa equipment compartment (line 1, line 2, neutral, and ground). Refer to wiring diagrams on pages 25 & 26. A green colored terminal (or wire connector marked "G",

Start Up Procedures

GR", "Grounding") is provided in the control box. To reduce the risk of electrical shock, connect this terminal or connector to the grounding terminal of your electrical service or supply service or supply panel with a continuous green insulated copper wire equivalent to the circuit conductor supplying this equipment, but no smaller than No. 12 AWG. In addition, a second pressure wire connector is provided on the surface of the control box for bonding to local ground points. To reduce the risk of electrical shock, this connector should be bonded with a No. 6 AWG copper wire to any metal ladders, water pipes, or any metal within 5 feet of the spa. Coleman recommends using copper wire for all electrical connections.

Jumper J23 Settings			
Input	Jumper Position	Heater & Hi Pump	Heater & Low Pump
120V/20A	20	No	Yes
120V/30A	50	Yes	Yes
240V/30A	20	No	Yes
240V/50A	50	Yes	Yes

Note: Never operate the spa when the water level is below water level mark on weir door. It can damage the pumps and heater and is potentially dangerous.

The UL and the NEC (National Electric Code) both dictate that the amperage rating and the amperage requirements be listed on all electrical appliances. We supply both the rating and the requirements printed on our spas and in our manuals. The rating merely designates a class or range of amperages. For example, an appliance rated at 40 amps may actually draw as little as 36 amps or as much as 44 amps. But it is rated at 40 amps regardless. In contrast, the requirement listed on an appliance states the size of load that the wiring, overcurrent protective device, etc. must be capable of supporting in order to supply current to this appliance. This requirement includes a built-in safety factor. Home inspectors, licensed electricians, and UL technicians receive training explaining the difference between these two terms.

The NEC states: "The ampacity of the branch circuit conductors, and the rating or setting of overcurrent protective devices, shall not be less than 125% of the load of the nameplate rating" see article 680-41h of the NEC and UL section 63.1

(UL Device Rating) times 125% = (Device Requirements)

(40 Amperes) times 125% = (50 Amperes)

Therefore a spa with a rating of 40 amperes will need an overcurrent protective device and copper wiring capable of handling 50 Amperes.

Start Up Procedures

Follow recommendations for site location and electrical connection. The water line on the weir door (see skimmer, page 4) is the level at which the water should be maintained.

1. Fill the spa through the filter hole to the water line on the weir door with tap water. Never use "softened" water in your spa.
2. Turn power on to unit at circuit breaker or disconnect.
3. Open the air controls and cycle the jets from high to low. Water should come from the therapy jets. If water flow is not established, turn off jets and see Priming Spa (page 20).
4. Add chemicals. See Chemical treatment and Water Maintenance section (page 16).

Follow Operating Instructions for your particular model and set the spa to heat to the desired temperature. Initially you may find that the spa requires 12 to 14 hours on 240 Volt installations to reach temperature. Keep your thermal cover on the unit and close the air controls to help the heating process.

Important: Do not operate the spa without full water flow.

Operating Instructions

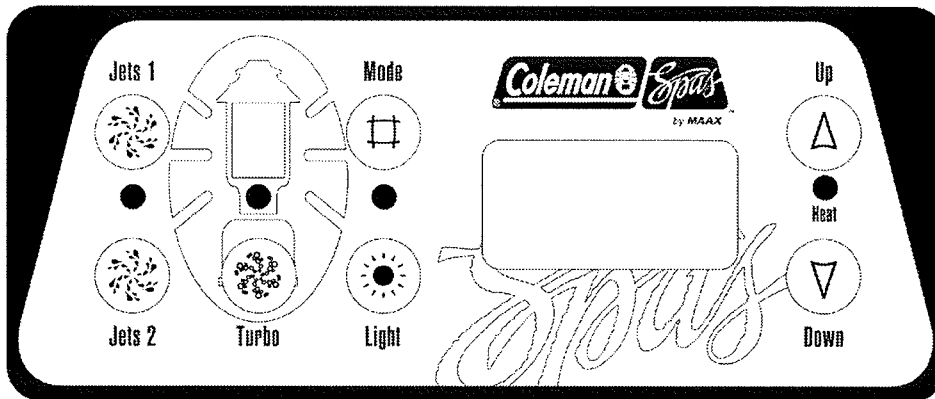

Powerworks 500 Series Control System - Models 506SL, 508SLII, 550SL, and 555SL

The 500 Series Powerworks Control offers you the ultimate in spa control. The backlit, Liquid Crystal Display (LCD) displays current water temperature, set point water temperature, and operating mode setting. Each feature of the system is actuated through the control panel pad. Simply touch the appropriate button to activate desired function.

At start up, when power is supplied to spa, the controls will operate properly and safely under the factory settings. The spa will be in Economy Mode, have a temperature setting of 100°F, and a filtration cycle duration of 3 hours (F3). To fully utilize the unique capabilities of the control system, it is important to know how to set the temperature, operate the pumps, operate the light, adjust the mode setting, and change the filtration cycles.

User's Pads

Temperature

The set temperature of your spa may easily be increased or decreased at any time using these buttons. The maximum set temperature is 104°F (40°C) and the minimum set temperature is 80°F (27°C). When either pad is touched, the set temperature will be displayed in the LCD window. Each successive touch will change the set temperature 1°F in the chosen direction. After 3 seconds the LCD will automatically display the water temperature.

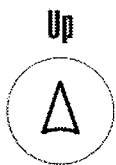

If the spa is set in Standard mode or in a filtration cycle, adjusting the set temperature may result in activating the heater. When the heater is operating, the LED

light between the buttons will light up.

Note: 240-Volt spas in the 500 Series that are wired with the 30 Amp option will not heat when Pump #1 is on in high speed, Pump #2 is on in high speed, or Turbo Air system is in operation.

Note: The “Up” and “Down” buttons are used with the inversion feature of the control system. (page 11)

Note: The “Up” and “Down” buttons are used while programming the duration of filter cycles. (page 10)



Jets 1

Touch this pad to activate the primary filtration pump. The sequence of the jet action is:

- 1—Low jets
- 2—High jets
- 3—Off

Jets 2

Touch this pad to activate the therapy-pump. The sequence of jet action is:

- 1—High jets
- 2—Off

The low speed operation of Pump 1 is timed to automatically turn off after four hours of operation. The high speed operation of Pump 1 and Pump 2 is timed to automatically turn off after 30 minutes of operation.

Note: Pump 1 will automatically operate in low speed whenever the spa calls for a filtration cycle or heat. When this automatic activation occurs, the low speed of Pump 1 can not be turned off; however all other control functions can be activated.

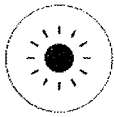

Light

Touch this pad to turn the internal spa light on and off. The spa light will automatically turn off after 60 minutes of operation.

Light

Note: Also used with Optional Fiber Optic system (see page 11).

Standard/Economy Mode

Mode

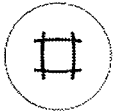

Your spa can be switched from Standard Mode to Economy Mode and vice versa by touching this pad. If your spa is in the Standard Mode, the low speed of Pump 1 and the heater will come on automatically to maintain the set temperature of the water. If your spa is set in the Economy Mode, the heater will operate ONLY during the filtration cycles.

The selected mode will be displayed in the LCD window of the control panel. When in Standard Mode a "Std" message will be displayed. When in Economy Mode a "Econ" message will be displayed. Under normal operation, the LCD display will alternate between the water temperature and mode setting.

Note: The Mode pad is also used while programming filtration cycles as shown in the next section.

Filtration Cycles

This control has been specifically designed so that by simply connecting the spa to its properly grounded source and touching the mode pad, the spa will function properly and safely at 100°F. In this mode, all user pads will be completely functional. However, to fully utilize the unique capabilities of this control, it is important to set the filtration cycles.

Preset Filter Cycles

Your control system is designed with two filter cycles. The first filter cycle will turn on 1 minute after applying power, the second will start 12 hours later. The filter cycles are preset at the factory for 3 hours.

For example: Spa is plugged in at 8:00 AM

Filter cycle #1 will run from 8:01 AM to 11:01 AM

Filter cycle #2 will run from 8:01 PM to 11:01 PM

At the start of each filter cycle, Pump 1 will come on in low speed. The heater will operate on demand if the controls are set in the Economy mode. At 20 seconds into the cycle, Pump 2 will come on in high

speed and operate for 30 seconds to purge the lines of the water system. If your spa is equipped with an ozone generator, it will be activated 60 seconds into the cycle.

Changing Filter Cycles

The duration of each filter cycle can be adjusted to 1, 2, 3, 4, 5, or 6 hours. The amount of time needed to filter your spa will vary depending on usage and ambient conditions. You will need to program your filter cycles based upon your personal use.

To change the duration of the filter cycles:

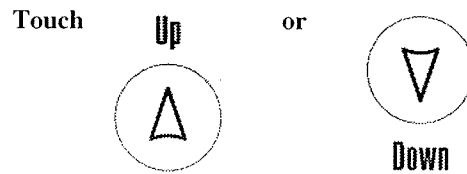

Then The center display will read:

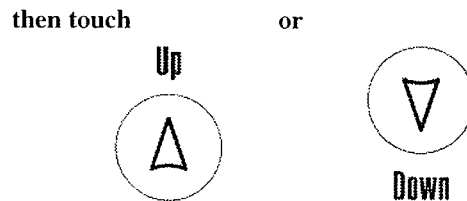

to adjust the cycle duration to the desired setting. After each press, the duration of the cycle will be displayed in the LCD window as follows:

- FIL 1 1 Hour for each cycle, 2 hours per day
- FIL 2 2 Hours for each cycle, 4 hours per day
- FIL 3 3 Hours for each cycle, 6 hours per day
- FIL 4 4 Hours for each cycle, 8 hours per day
- FIL 5 5 Hours for each cycle, 10 hours per day
- FIL 6 6 Hours for each cycle, 12 hours per day

To exit the filter-set procedure:

Touch

Mode

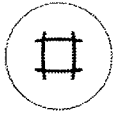

The LCD window should display the current water temperature.

If a change is made to the duration while the spa is in a filtration cycle, it will take effect immediately. If the change is made outside a filtration cycle, it will take effect at the start of the next scheduled cycle.

To change the starting times of your daily filtration cycles, you must turn off the circuit breaker to your spa and turn it back on at the desired start time for the first cycle.

Note: When power is disconnected from the spa, the controls will revert to the default factory settings. Any adjustments to set temperature or filter cycle duration will need to be reprogrammed.

Clean Up Cycle

After periods of heavy use, you can manually start a clean-up cycle by turning Pump 1 on in low speed. The pump will operate for 4 hours and then automatically turn off. The heater will also operate during this period if the controls are set in Standard Mode.

Inversion Feature

Your 500 series Control system is designed to include a display inversion feature. This feature allows you to invert the LCD display for easy viewing while enjoying your spa. To invert the LCD display:

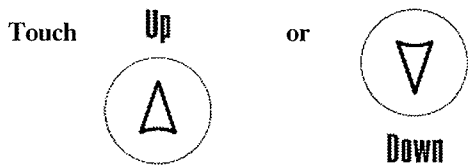

To cancel the inversion feature, simply repeat the sequence.

Turbo Air Operation (Optional)

All 500 Series spas, except the Model 502SL, are optionally equipped with a Turbo Air system to increase the performance and therapeutic action of the jets. To turn the Turbo Air system on and off:

Touch

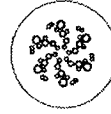

Turbo

The turbo air blower will automatically shut off after 30 minutes.

Note: At the start of each filtration cycle, the blower is activated to purge the lines and ensure complete filtration, ensure all air controls are fully open.

Fiber Optics (Optional)

All 500 series spas may be optionally equipped with a Fiber Optic system that replaces the internal spa light. The fiber optic system has 4 different color settings to increase your overall spa experience. To turn the Fiber Optic system on and off:

Touch

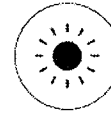

Light

Ozone Operation (Optional)

All 500 series spas may be optionally equipped with Coleman Spas' CleanZone® ozone water treatment system to assist with your water sanitizing needs. All factory installed ozonators are designed to work in conjunction with an injector system to maximize the sanitizing effects by fully mixing the ozone with the water flow.

CleanZone® will produce ozone only when the spa is in a timed filtration cycle. During the filter cycle, activating other functions will suspend ozone production for 30 minutes.

Note: Activating the low speed of Pump 1 for a clean up cycle will initiate filtration, but not ozone production, unless the spa enters a timed filter cycle during the 4 hour period.

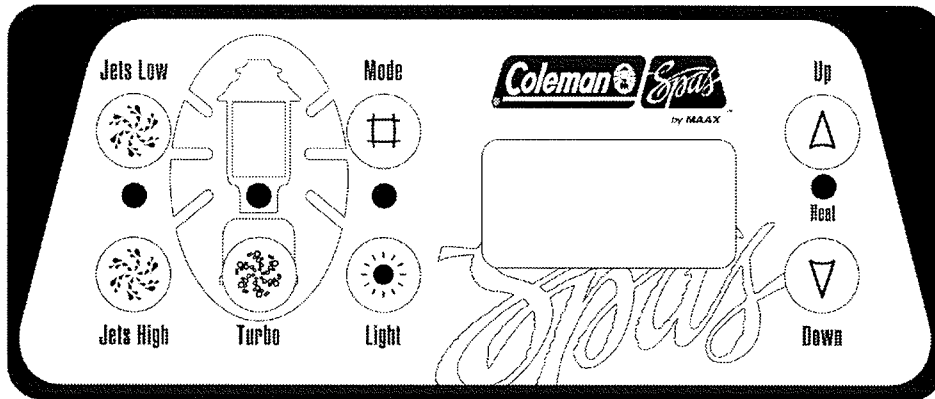

Powerworks 500 Series Control System - Model 502SL & 508SLI

The 500 Series Powerworks Control offers you the ultimate in spa control. The backlit, Liquid Crystal Display (LCD) displays current temperature, set water temperature, and operating mode setting. Each feature is actuated through the control panel pad. Simply touch the appropriate button to activate desired function.

At start up, when power is supplied to spa, the controls will operate properly and safely under the factory settings. The spa will be in Economy Mode, have a temperature setting of 100°F, and a filtration cycle duration of 3 hours (F3). To fully utilize the unique capabilities of the control system, it is important to know how to set the temperature, operate the pumps, operate the light, adjust the mode setting, and change the filtration cycle.

Up Temperature



The set temperature of your spa may easily be increased or decreased at any time using these buttons. The maximum set temperature is 104°F (40°C) and the minimum set temperature is 80°F (27°C).

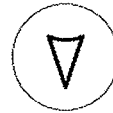

Down

When either pad is touched, the set temperature will be displayed in the LCD window. Each successive touch will change the set temperature 1°F in the chosen direction. After 3 seconds the LCD will automatically display the water temperature.

If the spa is set in Standard mode or in a filtration cycle, adjusting the set temperature may result in activating the heater. When the heater is operating, the LED light between the buttons will light up.

Note: Model 502SL spas that are wired 120V/20 amp will not heat when the pump is on in high speed.

Note: Model 508SLI spas that are wired 240V/30 amp will not heat when the pump is on in high speed or when the Turbo Air system is in operation.

Note: The “Up” and “Down” buttons are used with inversion feature of the control system. (Page 13)

Note: The “Up” and “Down” buttons are used while programming the duration of filter cycles. (Page 13)

Jets Low



Jets Low
Touch this pad to activate the low speed operation of the pump. The sequence of the jet action.

- 1 - Low whirlpool jets
- 2 - Off



Jets High
Touch this pad to activate the high speed operation of the pump. The sequence of the jet action is:

- 1 - High Thereapy jets
- 2 - Off

Jets High

The low-speed operation of the pump is timed to automatically turn off after four hours of operation. The high speed operation of the pump is timed to automatically turn off after 30 minutes of operation.

Note: The pump will automatically operate in low speed whenever the spa calls for a filtration cycle or heat. When this automatic activation occurs, the low speed of the pump can not be turned off; however all the other control functions can be activated.

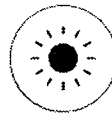

Light
Touch this pad to turn the internal spa light on and off. The spa light will automatically turn off after 60 minutes of operation.

Light

Note: Also used with Optional Fiber Optic sytem.

Standard/Economy Mode

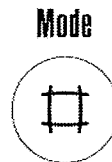

Mode
Your spa can be switched from standard Mode to Economy Mode and vice versa by touching this pad. If your spa is in the Standard Mode, the low speed of Pump 1 and the heater will come on automatically to maintain the set temperature of the water. If your spa is set in the Economy Mode, the heater will operate ONLY during the filtration cycles.

The selected mode will be displayed in the LCD window of the control panel. When in Standard Mode a "Std" message will be displayed, when in Economy Mode a "Econ" message will be displayed. Under normal operation, the LCD display will alternate between the water temperature and mode setting.

Note: The mode pad is also used while programming filtration cycles as shown in the next section.

Time and Filtration Cycles

This control has been specifically designed so that by simply connecting the spa to its properly grounded source and touching the mode pad, the spa will function properly and safely at 100°F. In this mode, all user pads will be completely functional. However, to fully utilize the unique capabilities of this control, it is important to set the filtration cycles.

Preset Filter Cycles

Your control system is designed with two filter cycles. The first filter cycle will turn on 1 minute after power is supplied to the spa. The second filter will turn on 12 hours later. The filter cycles are pre-set at the factory for 3 hours.

For example: Spa is plugged in at 8:00AM

Filter cycle #1 will run from 8:01AM to 11:01AM.

Filter cycle #2 will run from 8:01PM to 11:01PM.

At the start of each filter cycle, Pump 1 will come on in low speed. The heater will operate on demand if the controls are set in the Economy mode. If you spa is equipped with an ozone generator, it will be activated 60 seconds into the cycle.

Changing Filter Cycles

The duration of each filter cycle can be adjusted to 1, 2, 3, 4, 5, or 6 hours. The amount of time needed to filter you spa will vary depending on usage and ambient conditions. You will need to program you filter cycles based upon your personal use.

To change the duration of the filter cycles:

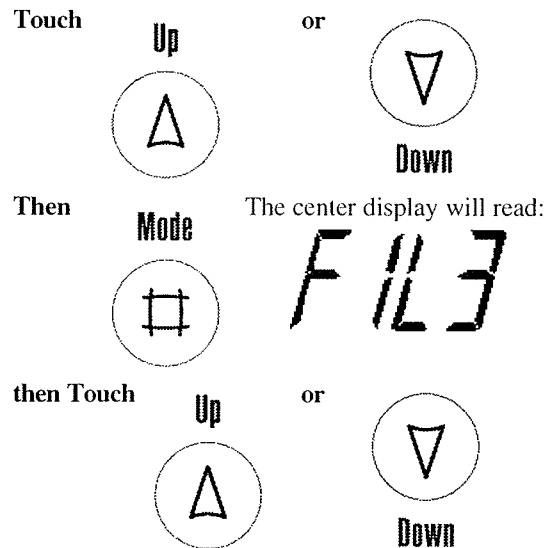

to adjust the cycle duration to the desired setting. After each press, the duration of the cycle will be displayed in the LCD window as follows:

- FIL1 1 Hour for each cycle, 2 hours per day
- FIL2 2 Hours for each cycle, 4 hours per day
- FIL3 3 Hours for each cycle, 6 hours per day
- FIL4 4 Hours for each cycle, 8 hours per day
- FIL5 5 Hours for each cycle, 10 hours per day
- FIL6 6 Hours for each cycle, 12 hours per day

Operating Instructions - Model 502

To exit the filter-set procedure

Touch Mode

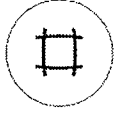

The LCD window should display the current water temperature.

If a change is made to the duration while the spa is in a filtration cycle, it will take effect immediately. If the change is made outside a filtration cycle, it will take effect at the start of the next scheduled cycle.

To change the starting times of your daily filtration cycles, you must turn off the circuit breaker to your spa and turn it back on at the desired start time for the first cycle.

Note: When power is disconnected from the spa, the controls will revert to the default factory settings. Any adjustments to set temperature or filter cycle duration will need to be reprogrammed.

Clean Up Cycle

After periods of heavy use, you can manually start a clean-up cycle by turning Pump 1 on in low speed. The pump will operate for 4 hours and then automatically turn off. The heater will also operate during this period if the controls are set in Standard Mode.

Inversion Feature

Your 500 Series Control system is designed to include a display inversion feature. This feature allows you to invert the LCD display for easy viewing while enjoying your spa. To invert the LCD display:

Touch

Up

or



Down

Then

Jets Low



To cancel the inversion feature, simply repeat the above sequence.

Turbo Air Operation (Optional)

The Model 508SLI may be optionally equipped with a Turbo Air system to increase the performance and therapeutic action of the jets. To turn the Turbo Air system on and off:

Touch

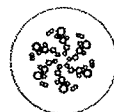

Turbo

The turbo air blower will automatically shut off after 30 minutes.

Note: The Turbo Air option is not available on the Model 502SL.

Note: At the start of each filtration cycle, the blower is activated to purge the lines and ensure complete filtration, ensure all air controls are fully open.

Fiber Optics (Optional)

All 500 series spas may be optionally equipped with a Fiber Optic system that replaces the internal spa light. The fiber optic system has 4 different color settings to increase your overall spa experience. To turn the Fiber Optic system on and off:

Touch

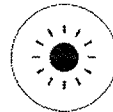

Light

Ozone Operation

All 500 series spas may be optionally equipped with Coleman Spas' CleanZone[®] water treatment system to assist with your water sanitizing needs. All factory installed ozonators are designed to work in conjunction with an injector system to maximize the sanitizing effects by fully mixing the ozone with the water flow.

CleanZone[®] will produce ozone only when the spa is in a timed filtration cycle. During the filter cycle, activating other functions will suspend ozone production for 30 minutes.

Note: Activating the low speed of Pump 1 for a clean up cycle will initiate filtration, but not ozone production, unless the spa enters a timed filter cycle during the 4 hour period.

Safety Features

Your Coleman Spa is equipped with several safety features which are designed to protect the user and the equipment.

Automatic Time Outs

The low speed whirlpool are timed to automatically turn off after four hours of operation. The high speed whirlpool and therapy jets and turbo are timed to turn off automatically after thirty minutes of operation. The spa light will turn off automatically after 60 minutes.

Error Messages

The 500 Series control systems are designed with several error messages that will automatically be displayed on the LCD screen. These messages help describe the operating status of your spa.



Overheat Protection

Each 500 Series control is equipped with two sensors to detect overheating conditions; a water temperature sensor and a hi-limit sensor. If a problem is detected with either one of the sensors the "OH" symbol will be displayed in the LCD window.

The water temperature sensor constantly monitors the temperature of the spa water. If at any time the spa water reaches a temperature of 112°F, the spa will be disabled. Once the water temperature cools down to a temperature below 110°F the spa will automatically be reset.

The hi-limit sensor constantly monitors the temperature of the heater housing. If at any time the heater housing reaches a temperature of 118°F the spa will be disabled. When the heater temperature cools down to 116°F, the spa can be reset by touching the "Mode" pad on the control panel. This overheating condition may be caused by restricted water flow or faulty flow switch and should be investigated thoroughly prior to resetting the controls.

Note: After an "OH" message, it is important that you check the water temperature before entering the spa.

Note: If the "OH" message remains, the spa water temperature does not go down, or the spa will not accept a reset, contact your dealer immediately and DO NOT use the spa.

Flow Switch



Each 500 series spa is equipped with a pressure switch located on the tailpiece of the heater that allows the control system to detect problems with the water flow conditions. If either a *Low Flow* or *No Flow* condition is detected the "FL" symbol will be displayed in the LCD window.

If the "FL" message alternates with the temperature display, a low flow situation has occurred. A low flow condition will occur when the pressure switch fails to close while the pump is operating. Check to make sure all slice valves are open, that there are no obstructions in the pump or water line, and that the filter is clean of any

debris. If the problem persists, contact your dealer for assistance.

If a solid "FLO" message is displayed in the LCD window, a no flow situation has occurred and the spa will be deactivated. A no flow condition will occur when the pressure switch is in a closed position without the pump running. Contact your dealer immediately for assistance and DO NOT use the spa.



Open Sensor Detection

If a problem is detected with either the water temperature sensor or the hi-limit sensor a solid "Sn" message will be displayed in the LCD window. The spa will be deactivated. Contact your dealer for assistance.

Your 500 Series control system is also equipped with a freeze protection program. When a freeze condition is detected (temperature of the heater tube is below 45°F) the system software will automatically activate the pumps to circulate the water. No message will be displayed in the LCD window. The operation of the pumps is a normal spa function and no corrective action is necessary.

Jets and Air Controls

Jets

Coleman's 500 series jets are individually engineered to provide a unique hydro-massage. The jet system is designed so that all like sized jet nozzles are interchangeable and can be added in any quantity. All full sized jets are adjustable from a fully open to closed position. It is very important that you NEVER SHUT ALL FULL SIZED JETS OFF AT ONE TIME! Depending on the model, your spa will have a combination of the following jets.

Cyclone Therapeutic (XL Cyclone, Cyclone, & LS Luxury):

Positioned to focus on large muscle groups, these jets deliver a concentrated, high volume stream of water for a deep massage. Each jet is fully adjustable, allowing users to set the water flow to the most comfortable setting. The nozzle can be rotated to target sore muscle areas.

Cyclone Turbo Swirl Jets (XL Cyclone, Cyclone, & LS Luxury):

Positioned to focus on muscle tension zones, these jets deliver a spinning V-shaped water stream for a gentle, pulsating massage. Each jet is fully adjustable, allowing users to set the water flow to the most comfortable setting.

Diverter/Whirlpool: Positioned to create overall water circulation, this multi-purpose, high volume jet provides whirlpool action throughout the entire spa. In the "on" position the high volume water stream provides either a deep massage for the lower back area or a soothing all-over body massage. In the "off" position, water flow is diverted to 3 or 4 other spa jets.

Euro Ozone Jets: Positioned in the footwell area of the spa, these jets deliver a penetrating massage to dissolve tension in the lower legs. This jet is the entry point for ozone produced during the automatic filtration cycles, and, as such, is not adjustable. Note: Ozone production is suspended when other functions are activated on the control panel by the spa user.

Comfort Collar

Select models in the 500 series are equipped with special above the waterline neck jets in the Comfort Collar. The intensity of the water flow to these jets can be controlled by turning the valve adjacent to the therapy seat.

Note: The comfort collar jets in the Model 506SL are not equipped with a control valve.

Air Controls

The intensity of the jet action can be controlled by altering the amount of air injected with water through the jets. Your spa has 2 to 4 air controls located on the lip of the spa. Each control activates air to specific jets in the spa allowing you to create various combinations and levels of jet action to suit individual taste.

Note: Air controls should be closed during heating cycles for maximum energy efficiency.

Maintenance

Water Chemistry

Water chemistry is critical in a spa system. The combination of high temperature and small volume means that the chemical balance must be watched carefully. It is recommended that you purchase a chemical start up kit from your dealer.

Sanitizing

Sanitizing your water destroys harmful organisms and keeps your spa healthy and safe. Three commonly used spa sanitizers or oxidizing agents are bromine, chlorine and ozone. Chlorine or bromine are chemicals that you will add to the water. Ozone is a gas that is produced by an ozonator and injected into the water. It is important that a residual of sanitizer remain in your water. High water temperature, aeration and use will increase the need for sanitizer. In addition to maintaining a residual, it is important to "shock" your spa water periodically and after heavy use. This addition of substantial amounts of sanitizer super-chlorinates the water and oxidizes non-filterable organic residue. Allow the sanitizer level to drop back to the residual amount before using. Also use your Clean Up Cycle, page 11 or 14, after heavy use for additional filtration.

pH Level

pH is a balance of acidity and alkalinity in the water. Maintaining proper pH is important for the effectiveness of your sanitizer, for user comfort and to prevent corrosion of the spa equipment.

Note: Keep a chlorine or bromine residual of 3.0 to 5.0 ppm. Tests should be done daily with your test kit.

Note: Never mix two chemicals together. Never store any chemicals in the equipment compartment.

Note: Do not use muriatic acid to balance pH as it will damage your spa surface and equipment.

Recommended Levels

pH: 7.2–7.6 (Ideal 7.4–7.6)

Sanitizer Residual: 3.5–5.0 ppm

Total Dissolved Solids: 100–200 ppm

Free Available Sanitizer: 3.0–5.0 ppm

Note: Make sure you use fresh test kit reagents. They lose their accuracy with age. Total Alkalinity: 80–100 ppm ideal for dichlor, trichlor, and bromine.

Water Maintenance With the CleanZone® Water Treatment System

Equipping your spa with a CleanZone® system is a smart decision. The use of ozone in conjunction with the normal spa sanitizing and water balancing chemicals will give you a cleaner, healthier spa environment. Maintenance and chemical usage will be significantly reduced, and you will enjoy the cleanest water which won't irritate your skin.

Sanitizing With Ozone

Spas vary in size and the amount that they are used will vary considerably from family to family. For this reason you will need to establish your sanitizing program based upon your own personal use. When using ozone you should start by balancing your water chemistry as you normally would. A spa should run and be ozonated no less than six hours per day. This starting point should not be considered final. If your spa is heavily used, this run time should be increased. Your spa produces ozone during filtration cycles. (See page 14.)

The amount of a residual sanitizer (chlorine or bromine) that you maintain in the water will also vary

depending on use. It is recommended that you maintain a residual of 3.0–5.0 ppm. Periodically, and after periods of heavy use, it is necessary to “shock” your spa with large amounts of sanitizer. The clean up cycle, page 11 or 14, will provide extra filtration during periods of heavy use.

Specialty Chemicals

Although ozone will greatly reduce the need for specialty chemicals, it is recommended to always have some on hand. There may come a time when you will be required to add some of these due to heavy usage of the spa or when changing the water.

Hot Water Guide

If you are in an area which has metals in the source water, a specialty chemical program should be followed to avoid staining.

These guidelines cover the most common procedures when operating a spa with ozone. Should you encounter a situation which you don't completely understand, contact your dealer for assistance.

Hot Water Guide

Problem	Cause	Solution
Cloudy Water	<ul style="list-style-type: none"> Inadequate filtration/dirty filter Excessive oils/organic matter Improper sanitation/bacteria High pH and/or high alkalinity Suspended particles/organic matter High total dissolved solids (TDS) 	<ul style="list-style-type: none"> Check to make sure the filter is running properly/Clean filter with a filter cleaner or degreaser. Shock the spa with a chlorine or bromine sanitizer/shock or other shock treatment product. Increase sanitizer level to balance water and shock if needed. Adjust pH; add appropriate sodium bisulfate product. Use clarifier Note: If using an ozone generator, do not use polymer based clarifiers. Depending on the severity-drain the spa to half and refill; or drain the spa completely, clean and refill.
Water Odor	<ul style="list-style-type: none"> Excessive organics/too many chloramines/insufficient free available sanitizer Improper sanitation Inadequate filtration Low pH 	<ul style="list-style-type: none"> Shock the spa with a chlorine or bromine sanitizer/shock or other shock treatment product. Increase sanitizer level to balance water; shock if needed. Check to make sure the filter is running properly/Clean filter with a filter cleaner or degreaser. Raise pH with sodium bicarbonate product. If metals are present, add chelating agent.
Chlorine Odor	<ul style="list-style-type: none"> Too many chloramines-insufficient free available chlorine Low pH 	<ul style="list-style-type: none"> Shock the spa with a chlorine sanitizer/shock or non-chlorine shock treatment. Adjust pH; raise pH with sodium bicarbonate product.
Bromine Odor/ Yellow Water	<ul style="list-style-type: none"> Low pH 	<ul style="list-style-type: none"> Adjust pH; raise pH with sodium bicarbonate product.
Musty Odor	<ul style="list-style-type: none"> Bacterial or algae growth 	<ul style="list-style-type: none"> Shock the spa with a chlorine or bromine sanitizer/shock or equivalent shock treatment product. If problem is visible drain, clean, refill and balance spa.
Foaming/Scum Ring Around the Tub	<ul style="list-style-type: none"> Build up of body oils, lotion and chemicals resulting from soap or detergent 	<ul style="list-style-type: none"> Add defoamer; or drain and refill.
Algae	<ul style="list-style-type: none"> pH Imbalance Low free chlorine or bromine concentration 	<ul style="list-style-type: none"> Adjust pH Shock with a chlorine or bromine sanitizer/shock or other shock treatment product.

Eye Irritation	<ul style="list-style-type: none"> • Low pH • Insufficient free available chlorine 	<ul style="list-style-type: none"> • Raise pH with sodium bicarbonate product. • Shock with a chlorine sanitizer/shock or other shock treatment product.
Skin Irritation/ Rash	<ul style="list-style-type: none"> • Unsanitary/polluted water • Soaking too long • Water temperature too high 	<ul style="list-style-type: none"> • Keep recommended sanitizer residual at all times; superchlorinate or use a non-chlorine shock treatment. • Soak for smaller intervals, such as 15 minutes. • Reduce water temperature.
Scale	<ul style="list-style-type: none"> • Too much calcium dissolved in water pH and total alkalinity too high 	<ul style="list-style-type: none"> • Add a scale control product. Adjust total alkalinity and pH levels by adding the appropriate sodium bisulfate product; with concentrated scale deposits-drain the spa, scrub the scale off, refill the spa and balance the water.
Erratic pH Test Results/Unusual pH Test Color	<ul style="list-style-type: none"> • Sanitizer level too high • Old pH indicator dye 	<ul style="list-style-type: none"> • Test the pH, when the sanitizer level is below 5 ppm • Replace the pH indicator dye.
Sanitizer Dissipating Too Rapidly	<ul style="list-style-type: none"> • Excessive organics in water • Temperature too high • Low pH • Low pH Corrosion of Metal Fixtures • Low calcium hardness • Low total alkalinity 	<ul style="list-style-type: none"> • Increase shock dosage; add sanitizer; have bathers shower before entering spa. • Reduce temperature. • Raise pH with sodium bicarbonate product. • Use a chelating agent if metals are present. Keep proper pH level (7.2 to 7.6). • Use a chelating agent if metals are present. Maintain minimum 150-200 ppm calcium hardness. • Use a chelating agent if metals are present. Maintain proper alkalinity for type of sanitizer used.

Spa Cabinet Care

The 500 series cabinets are made from quality handcrafted cedar and/or special high impact plastic. The wood has been treated with a sealer and stain prior to spa assembly to preserve its appearance and help prevent weathering. Further wood protection requirements depend on spa location (indoors or outdoors, sun, shade, etc.), and local climate conditions. Re-treat with an appropriate product recommended by your authorized dealer upon installation and 3 to 4 times per year.

Cleaning the spa cabinet: Rinse dirt and dust regularly with clear water. To remove stubborn dirt, grime, and mild discoloration, wash with a mild detergent and warm water.

Draining Your Spa

Always turn the spa heater and circuit breaker off when you drain your spa. Do not turn the spa heater back on until you have full flow coming out of your jets for several minutes.

The water level in the spa must be kept at its normal level water line mark. Note: Evaporation and splashing will cause the water level to drop.

High concentrations of impurities caused by water evaporation, body oils, perfumes, and other contaminants may accumulate in the spa and cannot be filtered out. Consequently, it is advisable to drain your spa and refill it with fresh water every six to eight weeks or more often, depending on the amount of use.

Drain Access

All 500 Series spas are equipped with both an internal and external drain. The external drain is used when draining and filling your spa for normal water maintenance purposes. The internal drain is used when Winterizing (page 21) your spa.

The external drain is located in the lower part of the front access panel. To use this drain, simply remove the outer black cap, connect a standard garden hose to the fitting, turn the back of the valve counter-clockwise 90°, then pull out to open the valve.

The internal drains are located behind either the front access panel (models 502SL and 506SL) or in the black pedestal base adjacent to the equipment service panel. To access these drains, simply remove the screws holding the access panel on and pull the drain hoses out. Once the drains have been pulled out, remove the caps on the drains, attach a garden hose to the faucets, and open the valves.

Note: Do NOT attempt to use the pump to drain the spa.

Note: Close and replace caps on all drains prior to refilling the spa.

Priming Spa

Be aware that after draining and refilling your spa you may need to discharge air in the system in order for the pump to operate again. Should you experience an air-lock, you can remove the filter and insert a garden hose into the center hole and flush water through the system.

Spa Surface Care and Cleaning

Your spa shell surface is made of acrylic. A minimum amount of care and cleaning will keep your spa looking new for years.

To protect your spa finish, always keep your cover on the spa when not in use.

Use a spa cleaner for residue and lime buildup at the water level of the spa surface. This can be applied to the acrylic surface with a soft cloth and wiped clean. Use small amounts to avoid polluting spa water. It may be necessary to lower the water level 2 to 3 inches before cleaning if heavily soiled at the waterline.

Use common household, non-abrasive cleaners to clean your spa shell. (For example: Lysol Basin, Tub & Tile Cleaner®; Glass Plus®; Mr. Clean®; and Top Job®, or a mild dishwashing detergent such as Ivory® Liquid.) Rinse well and dry with a clean cloth.

Do not allow your acrylic surface to come into contact with products such as acetone (nail polish

Never use abrasive cleaners.

remover), nail polish, dry cleaning solution, lacquer thinners, gasoline, pine oil, etc.

Remove dust and dry dirt with a soft, damp cloth.

Clean grease, oil, paint and ink stains with isopropyl (rubbing) alcohol.

Avoid using razor blades or other sharp instruments that might scratch the surface.

Filter Maintenance

The removable filter cartridge is located in the filter canister behind the skimmer. The filter should be inspected at least monthly during normal use, and more often when spa use is heavy.

Keep the filter clean! A clogged filter decreases both performance and water quality.

To clean the filter, simply follow these steps: (**Note:** It is not necessary to drain the spa.)

1. Turn the pump off.
2. Remove skimmer lid on top of spa.
3. Remove strainer basket.
4. Remove filter cartridge from the filter canister by grasping the top and lifting upwards.
5. Soak, filter in filter cleaner/degreaser and hose out filter cartridge, unless replacing with new cartridge.
6. Place filter cartridge back into filter canister. When the spa is empty, the Weir door may block the filter canister. You must hold it out of the way when reinstalling the cartridge. When the tub is full of water the door will float so you will have easy access for installing the filter cartridge.
7. Replace strainer basket and skimmer lid.
8. Turn the pump ON.

In addition to performing normal filter maintenance, it will be necessary to occasionally remove oils that coat the filter reducing filter flow. To remove these oils, soak the cartridge in a plastic pail containing a commercial filter cleaning solution (available from your Coleman Spas dealer or most pool supply stores). Follow the manufacturer's instructions for use.

We suggest that you replace your filter cartridge yearly to maintain optimum performance. Filter maintenance depends on usage. Coleman recommends the filter be cleaned once every 90 days at a minimum, more often after heavy use or if water becomes cloudy.

Winterizing

In cold climates where freezing temperatures occur, special care is required to prevent the possibility of damage to the spa and equipment due to freezing.

If you plan on using your spa during cold months, be sure your pump and heater are in good working order. The spa shell has been insulated to provide efficient operation in cold weather areas.

Special Note: If you do not intend to use your spa during the winter months and there is danger of freezing, the spa must be winterized! You must do the following:

1. Turn off all electrical power to the spa.
2. Drain spa of all water. Open all unions, and remove drain plugs from bottom of pumps. If you cannot draw off all of the water (especially from hoses) R.V. antifreeze should be added to the remaining water through the bottom of the skimmer and jets. If antifreeze is used, it must be an inhibitor Propylene Glycol such as Dow Frost available through Dow Chemical Distributors.
3. Be sure to drain all drain hoses.
4. The filter should be drained, and the cartridge removed and cleaned.
5. Check to see that there is no water in the heater element chamber.
6. Clean your spa as per previous maintenance instructions.
7. Cover your spa with a waterproof, water-shedding, impenetrable cover.

8. For further information on blowing out the plumbing lines and winterizing procedures, contact your local dealer.

Note: If you elect not to drain your spa and the temperature is going to be below freezing for extended periods of time, especially 0° and sub zero, it is best to operate the spa heater at high temperature (90°–100°F). If the tub is not going to be used and kept in the 100°F range, you may have problems if your power goes out. It is wise during these bad weather periods to set the thermostat higher. This will keep the spa water from freezing quickly if you have a power failure.

Light Bulbs

The Spa light bulb is serviceable from outside the spa. You must remove the side panel and insulation closest to the light. Once the panel is removed, look for the bulb holding bracket and pull bracket towards you to change the bulb.

Problem Solving Guide

Problem	Usual Cause	Solution
1. System not operating.	A. House circuit breaker tripped or if OFF position.	A. Reset circuit breaker on home breaker panel.
2. Heater not operating	A. Water level too low. B. Heater mode not selected. C. No power to heater. D. Thermostat set lower than water temperature. E. Heater not operating. F. Flow switch malfunction.	A. Add water to reach fill line on weir door. B. Refer to temperature and heater functioning. Control instructions on pages 9–15. C. Check house circuit breaker. D. Set to desired temperature. E. Contact dealer. F. Contact dealer.
3. Water not clean.	A. Clogged or blocked floor suction or skimmer. B. Filter clogged (dirty). C. Poor water chemistry. D. Insufficient filtering time. E. Improper maintenance. F. High content of solids in water.	A. Clean floor suction/skimmer. B. Clean or replace. C. See “Chemical Treatment” section. D. Run filtration mode longer. Contact dealer. E. See maintenance section. F. Use clarifier or drain and refill spa.
4. Abnormal water usage.	A. Excessive evaporation and/or splashing.	A. Use spa cover.
5. Overheating.	A. High ambient temperature	A. See page 6, Indoor Installation.
6. Low water flow from jets.	A. Operating in FILTER mode-low speed. B. Clogged or blocked suction or skimmer. C. Dirty filter. D. Jets in OFF position. E. Slice valves closed.	A. Select hi-speed jets. B. Clean floor suction/skimmer. C. Clean or replace. D. Open jets. E. Open slice valves.
7. No water flow from jets.	A. Pump not primed. B. Adjustable jets turned off. C. House circuit breaker tripped, no power to system. D. Faulty pump or motor. E. Pump surges. F. Slice valves closed.	A. See priming section page 20. B. Turn on jets. C. Reset circuit breaker at home panel. D. Contact dealer. E. Low water. Check level on Weir door. F. Open slice valves.

Problem Solving Guide

Problem	Usual Cause	Solution
8. Noisy pump and motor.	A. clogged floor suction or skimmer.	A. Clean floor suction/skimmer.
	B. Low water level.	B. Add water to normal water level (6" below lip).
	C. Damaged or worn motor bearings.	C. Contact dealer.
9. Water leakage from under spa.	A. Check unions & drain hoses.	A. Contact dealer.
10. No air flow from jets.	A. Air control not open.	A. Open control.
	B. Jet nozzle not seated properly.	B. Check jet nozzles.
	C. Jet nozzle missing.	C. Inspect jets.
11. Motor will not operate.	A. House circuit breaker tripped or in OFF position.	A. Reset circuit breaker
	B. Improper or defective wiring or electrical supply.	B. Contact dealer.
	C. Thermal Overload Protection switch tripped.	C. Auto reset after motor has cooled. Contact dealer if motor continues to cycle.
12. Black powder film around water line.	A. Wearing in of turbo/blower brushes.	A. Will disappear after use.
13. The spa will not shut off	A. Spa trying to heat	A. Check set temperature in Standard mode
	B. Spa is in filter cycle	B. Normal. No need to change.
	C. Spa is in standard Mode.	C. Check mode setting.

Spa Soaking Guidelines

1. Persons with heart disease, diabetes, high or low blood pressure or any serious illness, and pregnant women should not enter a spa without prior consultation with their doctor.
2. People with skin, ear, genital or other body infections, open sores or wounds should not use the spa because of the possibility of spreading infection.
3. Before entering, look at the water in your spa. If there is cloudiness or foaming, or if a strong chlorine smell is present, the water needs treatment. Soaking in such water greatly increases your chances of getting a skin rash (pseudomonas). Be sure to maintain the water properly. Ask your Authorized Coleman Spas Dealer for guidance.
4. Shower with soap and water before and after using the spa. Showering before use washes away many of the common skin bacteria, and removes lotions, deodorants, creams, etc. Perspiration and lotions will reduce the effectiveness of the sanitizer and lessen the ability of the filter to work efficiently.
5. Enter the spa slowly and cautiously. Be careful of your footing, and allow your body to gradually get used to the water temperature. Leave slowly as well, because your leg muscles may be sufficiently relaxed to make you a bit unsteady, and you may become lightheaded.
6. Soaking for too long makes some people nauseous, dizzy, lightheaded or faint. Don't soak in 104°F (40°C) water. If you wish to soak for a longer period of time in high temperatures, leave the spa after 15 minutes, shower, cool down and then return for another brief stay. In lower temperatures (e.g. 98.6°F—normal body temperature) most people can comfortably and safely soak for longer periods at one sitting. If you have any questions about what's right for you and your family, consult with your doctor.
7. Be sure you check the water temperature before and while in the spa.
8. Never use the spa while under the influence of alcohol.
9. With any drug or medication, consult with your doctor about potential harmful effects from combined use of the drug and hot water soaking.
10. Never use the spa when you are alone, for safety's sake.
11. Never allow children to use the spa unsupervised.

Technical Specifications

Structural Features	Model 502SL	Model 506SL	Model 508SLI	Model 508SLII	Model 550SL	Model 555SL
Western Red Select Cabinet	Horizontal	Horizontal	Horizontal/Vertical Mix	Horizontal/Vertical Mix	Horizontal/Vertical Mix	Horizontal/Vertical Mix
Dimensions (allow 1/2" variance)	78" x 51 1/2" x 29 1/2"	83 3/8" x 83 1/2" x 34 1/2"	72 1/2" x 88 1/2" x 29 1/2"	72 1/2" x 88 1/2" x 29 1/2"	88" x 88 1/2" x 34 1/2"	88" x 88" x 34 1/2"
Seating Capacity	2	6	4	4	6	5
Usable Gallons	135	330	235	235	355	335
Weight in lbs (empty / full)	335 / 1455	660 / 3425	605 / 2535	605 / 2536	675 / 3470	675 / 3470
Electrical Requirements	240V, 30A/50A 120V, 20A/30A	240V, 30A/50A	240V, 30A/50A	240V, 30A/50A	240V, 30A/50A	240V, 30A/50A

500 Series System Wiring Diagram - Model 502SL

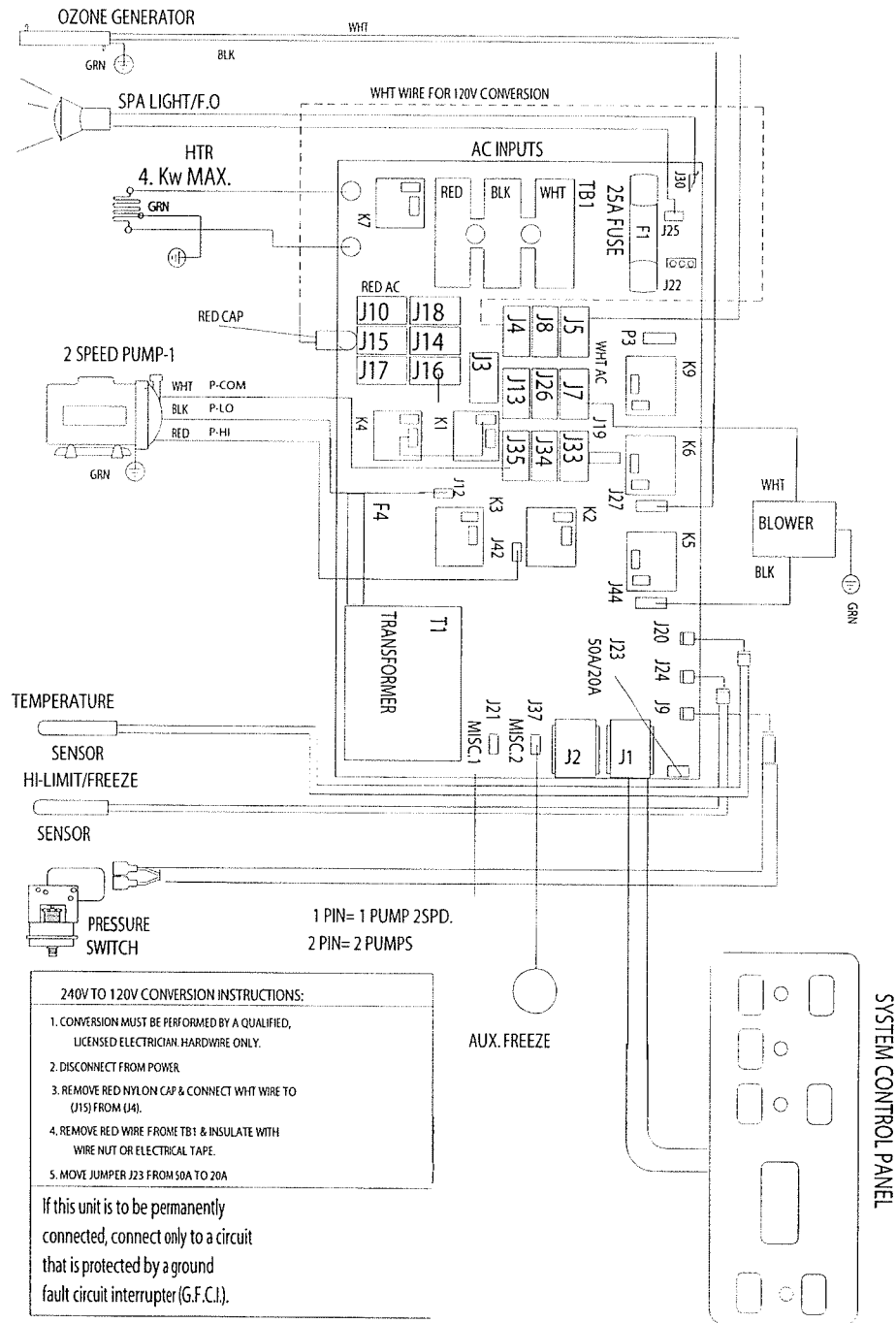

500 Series System Wiring

Diagram - Model 506SL, 508SLI, 508SLII, 550SL, & 555SL

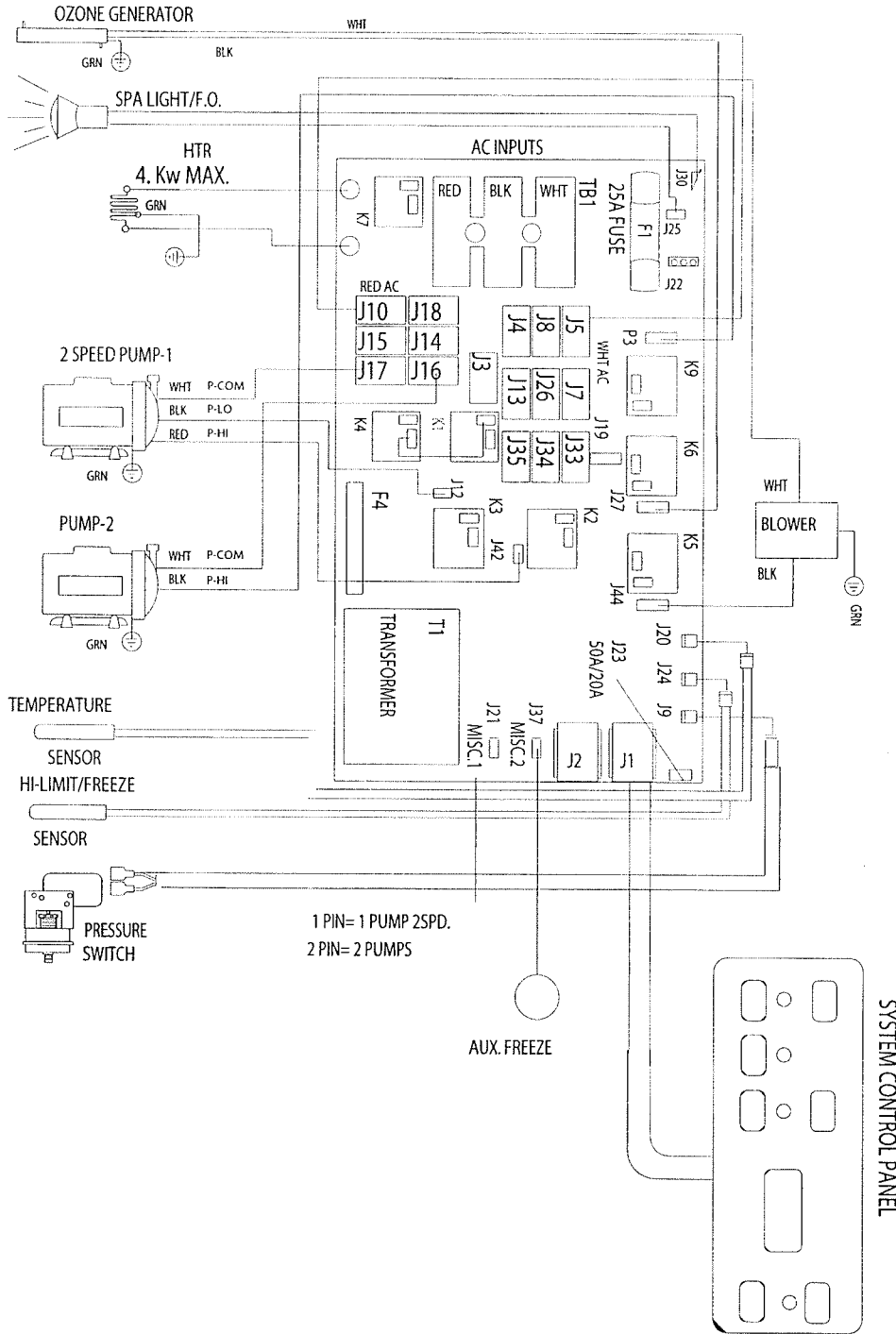

Safety Sign

The safety sign enclosed with your Owner's Manual should be permanently installed where visible to the users of the spa.

The sign is adhesive backed and there are also four screws supplied for mounting on rough surfaces.

It is very important that you, as a spa owner, review the important safety instructions before you operate your spa. It is equally important that you instruct all users, even occasional ones, as to the warnings associated with spa use.

You may obtain additional signs or replacement ones by contacting:

MAAX SPAS ARIZONA
Customer Service
25605 South Arizona Avenue
Chandler, Arizona 85248
1-800-223-4724



By MAAX

9501-6207 REV. 4/00
Retail Value \$9.95US

25605 South Arizona Avenue, Chandler, Arizona 85248
©1993-2001MAAX Spas (Arizona), Inc. • Printed in U.S.A.

