



OWNER'S MANUAL

This Owner's Manual has been expressly designed to acquaint you with your new tub's operation and general maintenance. We suggest that you take some time to carefully review all seven sections in this manual. Please keep this manual available for reference.

If you have questions about any aspect of your HOT SPOT's set-up, operation or maintenance, Watkins Manufacturing Corporation's Customer Service Department can be reached toll-free at:

WATKINS MANUFACTURING CORPORATION

1280 Park Center Drive, Vista, CA 92083
(800) 999-4688 (Extension 432)

OWNER'S RECORD

DATE PURCHASED:

DATE INSTALLED:

DEALER:

ADDRESS:

TELEPHONE:

SERIAL #:

The Serial Number/Identification label is located within the equipment compartment of your HOT SPOT. The serial number should also be documented on the delivery receipt from your dealer.

IMPORTANT: Watkins Manufacturing Corporation reserves the right to change specifications or design without notification and without incurring any obligation.

The following instructions are required to be printed by Underwriters Laboratories as a condition of their listing of this product. They contain important safety information, and we strongly encourage you to read and apply them.

IMPORTANT SAFETY INSTRUCTIONS

WHEN INSTALLING AND USING THIS ELECTRICAL EQUIPMENT, BASIC SAFETY PRECAUTIONS SHOULD ALWAYS BE FOLLOWED, INCLUDING THE FOLLOWING:

1. READ AND FOLLOW ALL INSTRUCTIONS.

2. **WARNING** - To reduce the risk of Injury, do not permit children to use this product unless they are closely supervised at all times.
3. **DANGER - RISK OF CHILD DROWNING.** Extreme caution must be exercised to prevent unauthorized access by children. To avoid accidents, ensure that children cannot use a hot tub or spa unless they are supervised at all times.
4. **DANGER - RISK OF INJURY.**
 - A. Connect only to a grounded, grounding type receptacle.
 - B. Do not bury the power cord.
 - C. **WARNING** - To reduce the risk of electrical shock, replace damaged cord immediately.
5. **DANGER** - To reduce the risk of injury to persons, **DO NOT** remove suction fittings. (Never operate spa if the suction fittings are broken or missing.)
6. **DANGER - RISK OF INJURY.** The suction fittings in this spa are sized to match the specific water flow created by the pump. Should the need arise to replace the suction fittings or the pump, be sure that the flow rates are compatible.
7. A ground terminal (pressure wire connector) is provided on the control box inside the unit to permit connection of a minimum No. 8 AWG (8.4 mm) solid copper bonding conductor between this point and any metal equipment, metal water pipe, metal enclosures of electrical equipment, or conduit within five feet (1.5 m) of the unit as needed to comply with local requirements.
8. **WARNING** - Your spa is provided with a ground-fault-circuit-interrupter located on the front face of the control panel. Before each use, with the unit operating, push the test button. The unit should stop operating and the reset

button should protrude. Push the reset button. The spa should now return to normal operation. If the interrupter fails to operate in this manner, there is excessive ground current leaking, indicating the possibility of an electric shock. Disconnect the power until the fault has been identified and corrected.

9. Install to provide drainage of the compartment for the electrical components.
10. **DANGER - RISK OF ELECTRICAL SHOCK.** Install at least 5 feet (1.5 m) from all metal surfaces. (A spa may be installed within 5 feet of a metal surface if each metal surface is permanently connected by a minimum No. 8 AWG (8.42 mm²) solid copper conductor attached to the wire connector on the terminal box that is provided for this purpose). National Electrical Code ANSI/NMFA70-1993.
11. **DANGER - RISK OF ELECTRIC SHOCK.** Do not permit any electrical appliances, such as a light, telephone, radio, or television within 5 feet (1.5 m) of a spa or hot tub.
12. **WARNING - TO REDUCE THE RISK OF INJURY:**
 - A. The water in a spa should never exceed 40 degrees Celsius (104 degrees F). Water temperatures between 38 degrees C (100 F) and 40 degrees C (104 F) are considered safe for a healthy adult. Lower water temperatures are recommended for extended use (exceeding 10 minutes) and for young children.
 - B. Since excessive water temperatures have a high potential for causing fetal damage during the early months of pregnancy, pregnant or possibly pregnant women should limit spa or hot tub temperatures to 38 degrees C (100 degrees F).
 - C. Before entering a spa, the user should measure the water temperature with an accurate thermometer, since the tolerances of water temperature regulating devices may vary as much as $\pm 3^{\circ}\text{C}$ (5°F .)
 - D. The use of alcohol, drugs or medication before or during spa or hot tub use may lead to unconsciousness with the possibility of drowning.
 - E. Persons suffering from obesity or with a medical history of heart disease, low or high blood pressure, circulating system problems, or diabetes should consult a physician before using a spa or hot tub.
 - F. Persons using medication should consult a physician before using a spa or hot tub since some medication may induce drowsiness while other medication may affect heart rate, blood pressure and circulation.

13. SAVE THESE INSTRUCTIONS

TABLE OF CONTENTS

Owner's Record	1	VI. SERVICE INFORMATION	
Important Safety Instructions	2	General Information	23
I. GENERAL INFORMATION		G.F.C.I. & High Limit Thermostat	23
DOs and DON'Ts	4	Miscellaneous Service & Information	23
Warnings	5	Equipment Removal & Installation	24
Tub Specifications & Illustrations	6	Acts Invalidating Warranty	24
		Disclaimers	24
		Troubleshooting Guide	25
II. INSTALLATION INSTRUCTIONS			
Site Preparation/Positioning Your Tub	7	VII. APPENDIX	
Electrical Requirements & Precautions	8	Skirt Installation Instructions	I
Skirt Installation Instructions	8	Cover Restraint Installation Instructions	II
Tub Installation Instructions	8	Approved Accessories & Tub Chemicals	III
		Warranty Service Form	IV
III. OPERATING INSTRUCTIONS			
Start-up Procedures	9		
Hydrotherapy & Heating Systems	10		
Stationary Jets	10		
Control Panel	10		
IV. TUB CARE AND MAINTENANCE			
General Information	11		
Draining the Water	11		
Filter Maintenance	11		
Care of the Exterior Finish	12		
Vacation Care Instructions	13		
Prevention of Freezing/Winterizing	13		
V. WATER QUALITY AND MAINTENANCE			
General Information	14		
Water Chemistry Terminology	14		
Use of the Test Kit or Test Strips	15		
Adding Tub Water Chemicals	17		
Sanitation	18		
pH Control	18		
Maintenance Schedule	19		
Supplemental Water Maintenance	20		
Troubleshooting Guide	21		
Chemical Safety and Storage	22		
Do's & Don'ts of Tub Water Maintenance	22		

I. GENERAL INFORMATION

Prolonged immersion in water that is warmer than normal body temperature can result in a dangerous condition known as HYPERTHERMIA. The causes, symptoms, and effects of hyperthermia may be described as follows: Hyperthermia occurs when the internal temperature of the body reaches a level several degrees above the normal body temperature of 98.6 degrees F. The symptoms of hyperthermia include dizziness, fainting, drowsiness, lethargy, and an increase in the internal temperature of the body. The effects of hyperthermia include (1) unawareness of impending hazard, (2) failure to perceive heat, (3) failure to recognize the need to exit the spa, (4) physical inability to exit the spa, (5) fetal damage in pregnant women, and (6) unconsciousness resulting in a danger of drowning.

WARNING — The use of alcohol, drugs, or medication can greatly increase the risk of fatal hyperthermia in hot tubs and spas.

Persons taking medications which induce drowsiness such as tranquilizers, anti-histamines or anti-coagulants should not use the spa. Pregnant women and persons with a medical history of heart disease, circulatory problems, diabetes or high blood pressure should consult their physician before using the spa.

Children are especially sensitive to hot water. At no time should children have unsupervised access to the spa. The use of elevated decking may encourage children to climb onto the thermal cover — **THE HOT SPOT IS SHIPPED WITH A COVER RESTRAINT FOR USE WITH THE SPLIT-TOP THERMAL COVER — INSTALL THE RESTRAINT FOR YOUR CHILDREN'S SAFETY.**

DO'S AND DON'Ts

- DO** disconnect the tub from the power supply before draining the tub or servicing the electrical components.
- DO** test the Ground Fault Circuit Interrupter monthly.
- DO** test the water temperature with your hand before entering the tub to be sure that it's comfortable.
- DO** remember that wet surfaces can be very slippery. Take care when entering and exiting the tub.
- DO** use the thermal cover when the tub is not in use, empty or full.
- DO** keep the water clean, clear and sanitized by correct chemical care.
- DO** follow the Tub Care and Maintenance recommendations stated in this manual.
- DO** clean the filter cartridge monthly.
- DO** turn the air control to the "Off" position after tub use.

- DON'T** use the tub for long periods of time at water temperatures in excess of 104 degrees F.
- DON'T** connect your tub to an extension cord.
- DON'T** allow the hydrotherapy jet pump to operate for extended periods of time with the thermal cover in place. Extended pump operation will cause a slow heat build-up due to water friction and will trip the tub's high limit thermostat.
- DON'T** operate the tub at any time with the filter cartridge removed or the filter compartment open.
- DON'T** store chemicals in the tub's equipment compartment.
- DON'T** roll the HOT SPOT on its vinyl skirt without providing padding or protection.
- DON'T** hesitate to call your Watkins Customer Service representative with any questions or maintenance problems.

WARNING: Watkins Manufacturing Corporation recommends that the HOT SPOT be installed above ground. Lowering the top of the tub to ground level, or employing decking which raises standing level toward the top of the tub substantially increases the hazard of accidental entry. Consult a licensed building contractor to design or evaluate your custom decking requirements.

WARNINGS

The following warnings contain important safety information, and we strongly encourage you to read and apply them.

WARNING:

1. A split-top cover restraint is included in the HOT SPOT Owner's Package. Watkins Manufacturing Corporation strongly recommends installing the restraint if your HOT SPOT is accessible by small children. The restraint should also be installed if your tub installation site is subjected to freezing temperatures or to high winds which may dislodge the thermal cover. (See Appendix for installation instructions.)
2. Use only approved accessories and recommended spa chemicals and cleaners.
3. Maintain proper water chemistry. The recommended level for your HOT SPOT is:

Free Available Chlorine (FAC): 3.0 - 5.0 ppm FAC

Water pH: 7.4 - 7.6

Total Alkalinity: 125 -150 ppm

Calcium Hardness 200 ppm

(Refer to Water Quality and Maintenance section for complete instructions.)

4. NEVER use an extension cord to connect the HOT SPOT to its power source. The cord may not be properly grounded and the connection is a shock hazard. An extension cord may cause a voltage drop which will cause over heating of the jet pump motor and motor damage.
5. Do not attempt to open the electrical control box. There are no user serviceable parts inside. Opening of the control box by the tub owner will void the warranty. If you have an operational problem, carefully go through the steps outlined in the Troubleshooting section. If you are not able to resolve the problem, contact your dealer or Watkins Manufacturing Corporation.

SAFETY SIGN

Effective December 13, 1993, each HOT SPOT will be shipped with a SAFETY SIGN in the owner's package. The sign, which is required by Underwriter's Laboratories as a condition of their listing of this product, should be permanently installed where it is visible to the users of the tub. To obtain additional SAFETY SIGNS, contact your HOT SPOT dealer and request Part # 34329.

TUB SPECIFICATIONS & ILLUSTRATIONS

HORIZONTAL DIMENSIONS:	73" (74" w/ cover)
HEIGHT (Without Cover):	29" (31" w/ cover)
EFFECTIVE FILTER AREA:	25 sq. ft.
HEATER (watts):	1000 w (1.0 kw)
WATER (capacity):	230 gallons
DRY WEIGHT (lbs.):	200# Dry, 2,120 Filled (w/ cover)
DEAD WEIGHT (lbs. per sq. ft. filled):	89 lbs. per sq. ft.
ELECTRICAL REQUIREMENTS:	115 volt/15 amp grounded circuit

OVERHEAD VIEW

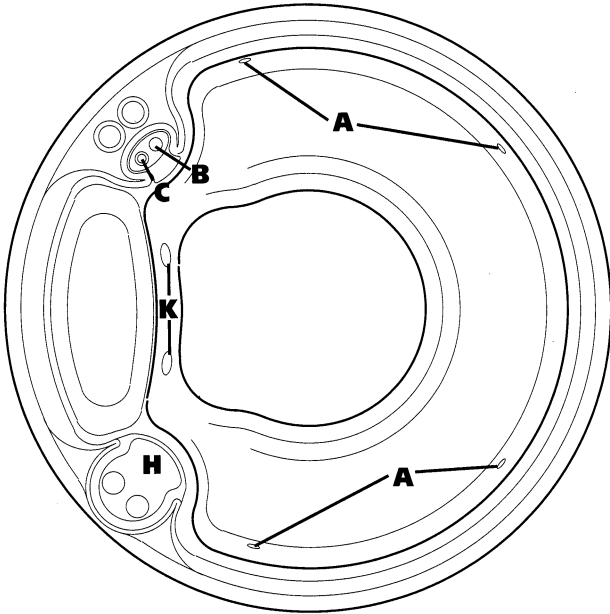

- A. Hydrotherapy Jet
- B. Hydrotherapy Pump ON/OFF Air Switch
- C. Hydrotherapy Jet Air Control Valve
- D. Heater High-Limit Thermostat
- E. G.F.C.I.
- F. Jet Pump
- G. 1.0 kw Heater
- H. Filter Compartment Cover
- I. Tub Drain Valve
- J. Circuit Breaker
- K. Jet Pump Anti-Suction Grill
- L. Temperature Control
- M. Compression Unions

EQUIPMENT COMPARTMENT

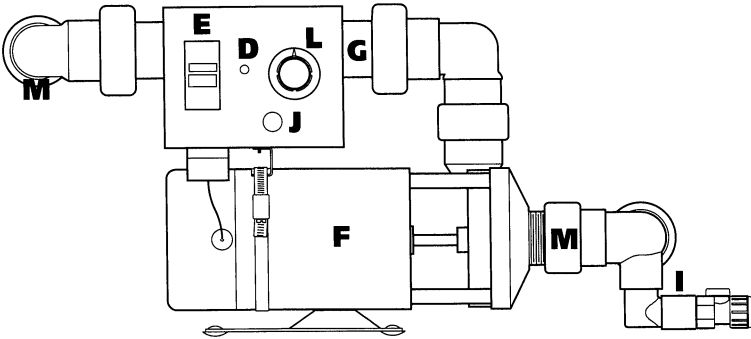

II. INSTALLATION INSTRUCTIONS

SITE PREPARATION/ POSITIONING YOUR TUB

Your HOT SPOT is totally self-contained and portable. You can locate it just about anywhere you wish---on a patio, deck, or even indoors. Regardless of your choice, the tub should always be placed on a structurally strong, level surface. The surface must be able to support the weight of the tub when it is filled with water and occupants. This weight could be as much as 120 pounds per square foot depending on the number of people in the tub. When selecting an installation site, be sure to allow for drainage away from the equipment compartment which houses the electrical components. The installation site should allow for easy access to the Ground Fault Circuit Interrupter (G.F.C.I.) switch which is located on the front of the control box (accessed through the vinyl skirt pane) for monthly testing. The 115 volt, 15 amp plug and the receptacle it is plugged into must be protected from weather and landscape sprinklers - - they should never get wet. Allowing moisture to enter the receptacle will result in tripping of the main circuit breaker in the house electric panel. Allow for access to the equipment compartment should service be required.

Outdoor/Patio Installation

The HOT SPOT has been engineered to be installed on all kinds of common yard surfaces. While a 3" - 4" thick reinforced concrete pad is best for long-term use, other foundations are acceptable so long as they are level. Probably the easiest foundation to prepare utilizes pea gravel or pre-cast stepping stones which are positioned in a level 6' x 6' square tub pad. It is important to note that soft foundations, even when stepping stones are used to evenly distribute the weight of the tub, may still have a tendency to settle thus resulting in an unlevel tub. Also, placing the tub on grass or dirt may increase the amount of debris which is inadvertently brought into the tub water on users' feet.

Deck Installation

Please refer to the Tub Specification Section of this manual for the dead weight per square foot. This figure does not take into consideration occupant weight. Should you be unsure of your deck's maximum load capacity, please consult a qualified building contractor or structural engineer.

Indoor/Basement Installation

Water which splashes on the floor during use of the tub may cause a walking hazard and/or structural damage to the dwelling; good drainage is mandatory! Proper

building materials must be used in the area surrounding and beneath the tub. Consider the room humidity which will exist due to high tub water temperatures. Providing natural or forced ventilation into the room will help maintain comfort and minimize moisture damage to the building. Consult an architect for aid in designing your indoor tub or garden room.

How to Unpackage and Move the Hot Spot

The HOT SPOT has been designed to be easy to move and install. For ease of handling, the HOT SPOT should be moved in its shipping carton as close as possible to the installation site before unpackaging. Next, with the carton flat on the ground, cut the plastic bands and stretch film around the carton. Lift off the cardboard top, remove the four spacers from inside the carton and then lift off the side panel. Either slide or lift the tub off the cardboard bottom.

Once the shipping carton has been removed, the Hot Spot should be left in its protective film packaging until moved into place. If the tub will have to be turned on its side and rolled through a gate or doorway — the Split-Top Thermal Cover **must** be removed first. Carefully pull back the top packaging film to allow removal of the two cover sections. All other packaging should remain intact. When rolling a wrapped HOT SPOT over a rough or sharp surface, or up or down stairs, or rolling an **unwrapped HOT SPOT at anytime**, always roll on furniture pads, thick blankets or use the flattened cardboard shipping carton.

IMPORTANT REMINDERS:

- The HOT SPOT weighs 200 pounds when in its packaging. At least two people are required to safely roll and set down the tub.
- Do not twist the tub back and forth while on its side. Abrasion to the vinyl skirt or trim ring may result.
- Do not roll the HOT SPOT with the split-top thermal cover in place.

INSTALLATION NOTES:

- 1) If you are an owner of a condominium, town home/patio home or are a member of homeowner's association, contact your representative regarding their requirements. If you have any questions regarding zoning requirements or building codes, contact your local city government office.
- 2) **IMPORTANT:** Watkins Manufacturing Corporation DOES NOT recommend the tub be shimmed if it is installed on an unlevel surface. The tub is designed to be installed on a relatively flat and level surface. Installing the tub on an unlevel surface will result in unlevel water and an aesthetically unbalanced tub but will not effect it's performance. Shimming of the tub may place additional stress on the tub's support system. Damage to the HOT SPOT caused by the incorrect installation of the tub is not covered by the tub warranty.

ELECTRICAL REQUIREMENTS AND PRECAUTIONS

GENERAL INFORMATION

Your HOT SPOT has been carefully engineered to provide maximum safety against electric shock. Remember, connecting the tub to an improperly wired circuit will negate many of its safety features. Please read and follow the electrical installation requirements and instructions completely!

Electrical Requirements

The tub must be connected to a 115 volt, 15 amp grounded circuit. A dedicated circuit is recommended; the term "dedicated" means the electrical circuit is not being used for any other high-load electrical items (patio lights, appliances, garage circuits, etc.). If the tub is connected to a nondedicated circuit, overloading will result in "nuisance tripping" which requires resetting of the breaker switch at the house electrical breaker panel. The circuit must be properly wired; that is, it must have a minimum 15 amp circuit breaker in the house breaker panel, #14 AWG or larger wire (including the ground wire) and the correct polarity throughout the circuit.

A pressure wire connector is provided on the exterior surface of the tub's electrical control box, located inside the equipment compartment. This is to permit the connection of a bonding wire between this point and any metal equipment, enclosures, pipe or conduit within five feet of the tub (if needed to comply with local building code requirements). The bonding wire must be at least a #8 AWG solid copper wire.

NEVER CONNECT THE TUB TO AN EXTENSION CORD!

SKIRT INSTALLATION INSTRUCTIONS

The HOT SPOT is available in either a standard "Factory Installed" skirt color model or in a skirtless model if a custom skirt color was selected at the time of purchase. HOT SPOT skirts have been specifically designed for quick and easy installation by the homeowner. Or if you prefer, your HOT SPOT dealer may offer skirt installation services for a nominal charge. If you choose to install the tub skirt, complete installation instructions are included in the custom/replacement skirt carton and can also be found in the Appendix section of this Owner's Manual. If you are replacing an existing tub skirt, only replace with a skirt manufactured by Watkins Manufacturing Corporation specifically for the HOT SPOT.

NOTE: HOT SPOT custom color skirts have been conveniently packaged for ease of storage should you wish to purchase an extra skirt color for a special occasion or a different tub site. For instance, you may wish to have a bright

skirt color when your tub is installed on your patio during the summer or during a tub party and then have a softer color skirt if your tub is moved indoors during the winter months.

IMPORTANT! A vinyl skirt **MUST** be installed on the HOT SPOT prior to use. Never operate the tub without a skirt! As vinyl material is susceptible to shrinkage in cold weather and expansion in hot weather, the skirt should be stored at room temperature before installation. Do not attempt to install a skirt in ambient temperatures below 60° F. The HOT SPOT skirt prevents moisture from entering the electrical components and protects the foam insulation.

TUB INSTALLATION INSTRUCTIONS

Each HOT SPOT comes equipped with approximately 15 feet of usable power cord (this is the maximum length allowed by Underwriters Laboratories and the National Electric Code). On "pre-skirted" and skirtless HOT SPOTs, the power cord is easily accessible at the bottom of the equipment compartment. To remove the power cord, locate the cord plug which was secured to the tub's drain valve and remove the tie-wrap. Carefully pull the cord out of the equipment compartment to the desired length.

For your safety, if you are having an electrician install an electric outlet for the tub OUTDOORS, it should be no closer than ten (10) feet and no farther than fifteen (15) feet from the tub. If the tub is being installed INDOORS, it should be no closer than five (5) FEET AND no farther than ten (10) feet from the tub. [Reference National Electrical Code 680 - 6a(1) and 680 - 41a.]

The Ground Fault Circuit Interrupter (G.F.C.I.) is located on the front of the tub's electrical control box. This device is for your protection. It is very important to protect it from rain and other moisture. Once a month, with the plug connected to the power supply, push the test button located on the G.F.C.I. The reset button should pop out, shutting off power to the tub. Next, push the reset button back in. The button should stay in restoring power to the tub. If the Interrupter fails to operate in this manner, there may be a ground fault indicating the risk of an electric shock.

Disconnect the plug from the receptacle until the source of the malfunction has been identified and corrected by an authorized service agent.

IMPORTANT: Should you ever find occasion to move or relocate your HOT SPOT, it is essential that you understand and apply its installation requirements. Your HOT SPOT has been carefully engineered to provide maximum safety against electric shock. Remember, connecting the tub to an improperly wired circuit will negate many of its safety features.

III. OPERATING INSTRUCTIONS

START-UP PROCEDURES

Your HOT SPOT tub has been thoroughly tested during the manufacturing process to ensure reliability and long term customer satisfaction. A small amount of water may have remained in the plumbing after testing and as a result may have spotted the tub shell or pre-installed tub skirt prior to delivery. Before filling the tub, wipe the tub shell clean with a soft rag or polish with Spa Shine. Your HOT SPOT dealer also carries Cover Shield which is a vinyl care product formulated to clean and protect the vinyl skirt material.

CAUTIONS:

- Do not fill the tub with hot water as damage to the control thermostat calibration or tripping of the high-limit thermostat may result.
- Do not connect power to an empty tub.
- Before using your tub after filling, super-chlorinate the tub water to ensure all bacteria and contaminants have been oxidized. (See Water Quality and Maintenance Section).
- Watkins Manufacturing Corporation does not recommend the tub be filled with "softened" water.

STEP 1: Ensure that the cap is on the tub's drain valve and the spigot is closed.

STEP 2: CAUTION: Ensure the filter cannister ring has been installed, the cannister ring lock engaged and the airbleed valve closed. Failure to lock the cannister cover in place may result in personal injury when the tub is turned on the first time.

STEP 3: Fill the tub with tap water to within 5 inches from the top.

STEP 4: Once the tub has been filled with water, plug in the power cord to the house receptacle, open the control access panel and push in the G.F.C.I. "Reset" button located on the front of the control box to supply power to the tub.

STEP 5: The jet pump, heating system and all internal plumbing will achieve a partial prime during filling of the tub with water. To check the operation of the jet system and purge any remaining air from the equipment and plumbing, push in the button labelled "JETS" (located on the top of the tub shell) to get the jet pump operational. To purge any remaining air from the filter cannister, slowly open the airbleed valve until water sprays from the valve. Close the bleed valve and place the padded filter cover over the filter compartment. Priming of the system is now complete.

IMPORTANT: The air control which is located on the top of the tub shell and labelled "AIR" should be set to the "ON" position when checking jet operation. **Always turn the air control to the "OFF" position anytime the tub is not being used.** This will help to make the tub operate quieter and heat more efficiently when the thermal cover is in place.

STEP 6: IMPORTANT: First adjust Total Alkalinity, calcium hardness, water pH and finally sanitize (super-chlorinate) the tub water by following the procedures listed in the Water Quality and Maintenance Section.

OPERATION NOTE: Adjusting the Total Alkalinity (TA), as the first step is important, as out-of-balance TA will affect your ability to adjust the pH correctly and prevent the chlorine from sanitizing effectively.

STEP 7: Once the tub water has been chemically balanced and sanitized, shut off the jet pump and turn the air control to the "OFF" position. Place the thermal cover on the tub and secure in-place using the cover restraint (see WARNING #1, page 5 and refer to the Appendix for installation instructions).

STEP 8: Open the equipment access panel and turn the "TEMPERATURE CONTROL" on the control box to number 7. Within 18 to 24 hours, the tub water will reach a temperature of approximately 100 degrees F. A water temperature not exceeding 104 degrees F can be achieved by setting the Temperature Control not higher than number 7 1/2 (halfway between #7 and #8). Please note, the numbers around the temperature dial are reference points to be used during temperature adjustments. They do not reflect the actual water temperature of the tub. If you find that you prefer cooler water, rotate the temperature control toward the next lower number. Conversely, if you prefer warmer water, rotate the temperature control toward the next higher number. Remember that a small change of the temperature control will yield a difference of several degrees, so make small adjustments until you find your preferred temperature. Allow several hours between adjustments. Thereafter, the water will remain within one degree of your selected temperature.

OPERATION NOTE: The HOT SPOT is equipped with a ten minute timer-delay on the heat cycle. Whenever the jet pump has been turned off (and a one degree temperature drop has occurred) or the temperature control has been turned up, it will take ten minutes before the low-speed of the jet pump and heater become activated. Always push the JET button to turn off the jet pump when exiting the tub. The HOT SPOT heating system does not operate simultaneously with the high speed of the jet pump.

HYDROTHERAPY & HEATING SYSTEMS

JET PUMP SYSTEM

The HOT SPOT utilizes a 2-speed pump to operate both its hydrotherapy jets and circulate the water through the heating system. On the low-speed, which is activated by the control thermostat, water will slowly be drawn in through the suction intakes and into the pump and then pushed through the heater, filter and back into the tub through the four jets. When the "Jet" switch is pushed, the high-speed of the jet pump will be activated and the heater will become deactivated. In a 115 volt electrical system, the tub heater will not operate simultaneously when the jet pump is operating on high-speed, even if a drop in the water temperature has occurred. Once the high-speed of the jet pump is turned off and the thermostat senses a 1 degree F. temperature drop, the heater and low-speed of the jet pump will be activated (Within 10 minutes of the jet pump high-speed being turned off).

IMPORTANT: The 115 volt electrical system of the HOT SPOT is not convertible to a 230 volt system. Any modification to the original equipment will void the tubs U.L. Listing, result in an unsafe tub and void the tubs warranty! Never operate the tub with the equipment compartment access door removed.

STATIONARY JETS

The stationary hydrotherapy jets are adjustable. The intensity of these jets is determined by the volume of water being pumped into the jet chambers and mixing with air. The air control valve can be utilized to change the intensity of all four jets simultaneously. Each jet is also adjustable; turn the jet nozzle either clockwise to decrease jet pressure or counter-clockwise to increase jet pressure. Closing one or two adjustable jets will make the remaining jets stronger. In addition, the jets of the HOT SPOT are interchangeable to accommodate a rotary jet nozzle. Contact your dealer regarding the purchase of Rotary Jet Kits for your HOT SPOT.

CONTROL PANEL

The control box of the HOT SPOT is attached to the equipment skid pack. DO NOT open the control box as there are no user serviceable parts inside and opening it will void the warranty. The operation and function of each of the switches or controls is explained as follows:

G.F.C.I. - The Ground Fault Circuit Interrupter is a safety device that is designed to sense as little as 5 milliamps of electrical current leakage to ground. Watkins Manufacturing recommends that the G.F.C.I. be tested monthly to ensure it is functioning correctly. With the plug connected to the power supply and the tub operating, push the

"TEST" button. The tub should stop operating and the "RESET" button should appear. Reset the G.F.C.I. by pushing in the "RESET" button. The tub will now operate normally. If the interrupter does not perform in this manner, a ground current is flowing indicating the possibility of an electric shock. Disconnect the plug from the receptacle until the fault has been identified and corrected. Test the G.F.C.I. monthly.

HEATER HIGH-LIMIT SWITCH - The heater high-limit thermostat sensor is secured to the heater housing. If for any reason the internal temperature of the heater exceeds 120 degrees F., the red "RESET" button on this switch will trip and turn off the tub. This switch is described as "trip free"; that is, it cannot be reset or the circuit closed by physically holding in the button, until the sensor cools to approximately 110 degrees F. The cause of the tripping must be located to prevent a reoccurrence. The most common cause of limit-tripping is allowing the jet pump to run on high-speed for an extended period of time (12-16 hours) which will cause a slow increase in the tub's water temperature. This results from both water friction and the transfer of heat from the jet pump. As the water temperature approaches 118 degrees F., the Heater High-Limit Switch will trip. Once the sensor cools, reset the switch. The reason for tripping could also be a result of inadequate water flow through the system. This is caused by an obstruction within the pump water lines, the non-function of the low-speed of the jet pump, or the malfunction of a regulating switch.

TEMPERATURE CONTROL - The temperature control is used to regulate the water temperature of the tub. As stated in the Start-up Procedures, a water temperature not exceeding 104 degrees F. can be achieved by setting the dial not higher than number 7 1/2. Please note, the numbers around the dial are reference points to be used during temperature adjustments. They do not reflect the actual water temperature of the tub. Once the dial has been set and the water temperature stabilized, then the water will stay within 1 degree of your selected temperature.

CIRCUIT BREAKER - The HOT SPOT is equipped with a mini-circuit breaker for protection of the equipment in the event of a circuit overload within the spa controls and to preclude reliance on the house circuit breaker. If the circuit breaker "trips", identify and correct the cause and reset the breaker (See Troubleshooting Guide).

IV. TUB CARE AND MAINTENANCE

GENERAL INFORMATION

Your HOT SPOT is manufactured from the highest quality, most durable materials available. Even so, Watkins Manufacturing Corporation recommends that a tub care and maintenance program be followed to increase your comfort and maintain the tub's reliability. The tub care and maintenance program you follow will ultimately determine how long your tub or its individual components will last. The following maintenance section when adhered to, will help you protect your investment.

DRAINING THE WATER

Detergent residues from bathing suits as well as soap film from your body may gradually accumulate in the water. Your HOT SPOT dealer offers soap foam inhibitors which will suppress the foam but cannot remove soap from the water. The soap is not oxidized by any chemical. Eventually the soap build-up in the water will be concentrated enough to leave an unclean feeling on the user's skin, cause sudsing and make the water impossible to clarify. Depending on the amount of soap input, the tub water should last between two and three months.

NOTE: Showering without using soap prior to entering the tub or only using a "rinse" cycle when laundering your bathing suit will help to avoid detergent residue in the tub water.

TO DRAIN YOUR TUB:

1. Disconnect the tub from the power supply by removing the power cord from the house receptacle.
2. Locate the tub drain near the bottom right corner of the equipment compartment and remove the drain cap. (Removal of the tub skirt is not required.) Attach the inlet of a garden hose to the drain valve and route the outlet of the hose to an appropriate draining area.

IMPORTANT: Tub water with a high sanitizer level may harm plants and grass.

3. Open the valve and the tub will drain almost completely by gravitational flow. Water remaining in the tub after draining may need to be bailed out using a soft plastic cup.
4. When empty, inspect the tub shell and clean as required. (Follow Care of the Vinyl Skirt and Tub Shell Instructions).

5. Remove the filter cartridge and clean as required.
6. Close the drain valve and replace the drain cap; replace the filter cartridge and secure the cannister ring.
7. Refill the tub BEFORE restoring power to it.

NOTE: Always sanitize and chemically balance the tub water after cleaning and refilling the tub.

8. Replace the split-top thermal cover on the tub.

FILTER MAINTENANCE

As with any water filtering system, a clogged filter cartridge will result in reduced water flow. In your HOT SPOT it is important to maintain a clean, unobstructed filtering system to provide maximum performance from the hydrotherapy jets. Watkins Manufacturing recommends the filter cartridge be cleaned (either spraying clean with water or soaking to dissolve minerals) EVERY MONTH!

CAUTION! To reduce the risk of spilling tub water, do not turn on the jet pump with the filter cannister cover removed.

TO REMOVE AND CLEAN THE FILTER CARTRIDGE:

1. Disconnect the tub from the power supply.
2. Remove and carefully set aside the filter compartment cover.
3. Lift the filter cannister ring lock and turn the ring counter-clockwise. Carefully pull upward on the cannister cover to remove it from the filter cannister and then set it aside.
4. Remove the filter cartridge and place it on a clean surface. Spray the cartridge using a garden hose. It will be necessary to rotate the cartridge while spraying so as to thoroughly remove debris lodged between the filter pleats.
5. After allowing it to dry, inspect the filter cartridge for calcium deposits (scaling) or an oil film.

SERVICE NOTE: Extremely hard water will cause a rapid build-up of minerals on the cartridge. Additionally, the use of oil-base tub water scents and body oils may coat the filter cartridge. The use of a garden hose will not remove the mineral deposits or oil film. A filter cartridge cleaner for soaking the cartridge is available from your HOT SPOT dealer and should be used as part of your tub maintenance program.

6. Use a rag to wipe out any debris which may be in the bottom of the filter cannister. Replace the filter cartridge, cannister cover and cannister ring lock. Carefully set the filter compartment cover back over the top of the cannister cover.

NOTE: The air will need to be purged from the filter cannister after every time the filter has been cleaned. (See Start-Up Procedure STEP 5).

CARE OF THE EXTERIOR FINISH

Tub Shell

Your HOT SPOT is manufactured with a high quality polypropylene shell. Stains and dirt generally will not adhere to this surface. Cleaning of the surface at the waterline to remove any body oil or "bath tub ring" can be done easily with baking soda and a soft sponge. When your tub has been drained for cleaning, the use of a spa/tub surface cleaner is recommended to clean the tub shell. The use of a soft rag, soft sponge or nylon scrubber should easily remove most dirt buildups. The use of Spa Shine is recommended after the tub shell has been dried to polish the surface.

SERVICE NOTES: 1) Iron and copper may stain the tub shell if allowed to go unchecked. Your HOT SPOT dealer stocks a Stain and Scale Inhibitor to use if your water has high concentrations of dissolved minerals. 2) Your dealer may also stock Scum Balls which can be used in your tub to help control "bath tub ring".

IMPORTANT: Always thoroughly rinse off any tub shell cleaning agent. Some surface cleaners contain eye and skin irritants. Keep all cleaners out of reach of children and use care when applying.

Vinyl Tub Skirt

The vinyl tub skirt of the HOT SPOT is manufactured from durable U.V. resistant material. Even so, monthly cleaning and periodic conditioning is recommended to maintain its beauty. To clean and condition the vinyl skirt:

1. With a garden hose, lightly spray the skirt to rinse away and loosen any dirt or debris.
2. Using a large sponge or soft cloth, and using a very mild soap solution (1 teaspoon dishwashing liquid with 2 gallons of warm water) or saddle soap, scrub the vinyl in a circular motion. Use care not to let the vinyl dry with a soap film on it before it can be rinsed clean.
3. Lightly spray the tub skirt to rinse away the cleaning solution.

IMPORTANT: To avoid soap getting into the tub water, the tub cover should be left on the tub during cleaning and rinsing.

4. To condition the vinyl after cleaning, apply a thin film of Cover Shield and buff to a high lustre.

SERVICE NOTE: To remove tree sap, use lighter fluid (not charcoal lighter but the kind used in cigarette lighters). Use sparingly and rinse with a mild soap solution afterwards. Wipe dry.

Thermal Cover

The HOT SPOT split-top thermal cover is a durable, foam-filled, U.V. stabilized, polyethylene product designed for year-round use. As with the tub shell and vinyl skirt, the thermal cover will retain its original beauty if it is maintained correctly. This includes monthly cleaning, periodic polishing and preventative maintenance during the winter or adverse weather conditions.

To ensure many seasons of use, the following use and care instructions should be noted:

1. Remove the two cover halves from the tub and gently lean them against a wall or fence.
2. With a garden hose, spray the cover halves to rinse away and loosen dirt or debris.
3. Use a large sponge or soft cloth to apply a spa/tub shell surface cleaner to the top and sides of the cover. Do not apply to the bottom surface of the cover.
4. After allowing the cleaner to set on the surface for a minute or two to soften the dirt, scrub the cover.
5. Thoroughly rinse off the cover after cleaning and wipe dry.
6. The use of Spa Shine is recommended after the surface has been dried to polish the plastic surface.
7. Use a damp cloth to remove any dirt from the bottom of the cover halves before replacing them back on the tub.

IMPORTANT REMINDERS:

- DO remove snow build-up to avoid possible surface damage from the additional weight.
- DO attach the cover restraint to secure the split-top cover to the tub to prevent access by small children and prevent the cover from becoming dislodged in high winds.
- DO NOT drag the tub cover.
- DO NOT walk, stand or sit on the tub cover.

IMPORTANT: Whenever the tub is not in use, it is essential that the thermal cover be in place. When filled, this ensures effective temperature maintenance and economical operation. When empty, this prevents potential damage to the surface finish of the interior walls which can result from the excessive heat of the sun. This type of damage is specifically excluded from warranty protection.

VACATION CARE INSTRUCTIONS

If you plan to be away, follow these instructions to ensure the water quality of your tub is maintained:

Short Time Periods (3-5 Days):

1. Adjust the water pH by following the instructions outlined in the Water Quality and Maintenance Section.
2. Sanitize the water by following the "super-chlorination" procedures also listed in the Water Quality and Maintenance Section. Make sure the air control is turned to the "OFF" position.
3. Secure your thermal cover in place using the cover restraint.
4. Upon your return, sanitize the water (super-chlorinate, if necessary) and balance the pH.

Long Time Periods (5-14 Days):

If you will not be using your tub for an extended period of time (more than 5-7 days) and an outside maintenance service (or neighbor) is not available to assist with the water maintenance, draining or winterizing of the tub is recommended.

PREVENTION OF FREEZING/WINTERIZING

The HOT SPOT has been designed and engineered for year-round use in any climate. In some areas, extremely cold temperatures combined with strong wind will result in a decrease in the tub's energy efficiency because the heater will cycle on more frequently. To help maintain the tub's energy efficiency, the cover restraint should be installed and tightly secured.

In very cold weather you may not want to venture outside to use your tub. In this case, you can easily move the HOT SPOT to a heated area, or leave it where it is until the weather warms. If you do leave the tub unused for a long period of time in severely cold weather, you should drain the water to avoid accidental freezing due to a failure in your utility's power supply.

To winterize the tub, first perform the Draining the Water instructions mentioned at the beginning of this section. Then:

1. Remove the filter cartridge, clean and store in a dry place. Clean and store the filter compartment cover as well.
2. Wipe the inside of the tub and filter canister completely dry.
3. To ensure the internal plumbing has drained completely and to remove any water that may be remaining in the jet pump, a wet/dry shop vac can be used at the tub drain. If you do not have access to a wet/dry shop vac, carefully lift the side of the tub (opposite the equipment compartment) approximately one foot off the ground to assist in drainage. Once you are sure the internal plumbing has drained completely, set the tub flat again.
4. Coil the power cord and place it in the equipment compartment. Leave the drain valve open during winterizing months.
5. Place the split-top thermal cover back on the tub and cover the HOT SPOT with a tarp.

To Reactivate:

Reinstall the filter cartridge, close the tub drain and replace the drain cap. Follow the Start-Up Procedures to get your HOT SPOT operational.

ACCESSORY NOTE: Your dealership stocks the HOT SPOT Dust Cover which is designed to completely cover the tub and Split-Top Cover. The dust cover will help to keep the HOT SPOT skirt and cover clean during periods of time the tub is winterized or not used.

V. WATER QUALITY AND MAINTENANCE

Introduction

Just as the care and maintenance of your tub is important to maintaining its value and ensuring trouble-free performance, water quality and maintenance is important for user enjoyment and protection. It is important to note that while at first you may be overwhelmed by the amount of information contained in this section, tub water maintenance actually consists of three separate, easy-to-develop programs. They are:

- Sanitizing and maintaining a safe level of sanitizer in the tub water.
- Balancing the pH and maintaining the recommended mineral content levels in the tub water.
- Achieving and maintaining water clarity.

Once you have had an opportunity to read this section and apply the information during the first 30 days of tub ownership, you will be well on your way to developing a Water Quality and Maintenance Program. It will be based upon your tub use (frequency and duration), user load (number of tub users), rate of contamination (again dealing with number of tub users and frequency), and the beginning mineral content of your tap water. Should you have any questions regarding tub water maintenance that have not been answered in this section or by your authorized HOT SPOT dealer, please contact Watkins Manufacturing Corporation's Service Department at the number listed on the inside first page of this Owner's Manual.

GENERAL INFORMATION

Safe, comfortable and clean tub water isn't difficult to achieve. However, a total tub water maintenance program is required. This program encompasses not only water circulation and filtration, but also correct tub water chemistry achieved through water sanitation and mineral balance. Watkins Manufacturing Corporation recommends the following tub sanitation and pH control procedures (based on average tub use in an ideal situation). Additionally, your HOT SPOT dealer is a trained professional who can assist you in developing a start-up and maintenance program based on your "tap water" mineral content and the average user load for your tub. Check with your dealer, many offer in-house water analysis to assist in resolving specific water chemistry problems.

Tub water sanitation is chemically achieved with CHLORINE (Sodium/Dichloro-S-Triazinetrione or Sodium Dichloro-Isocyanurate). Mineral balance and pH control are chemically achieved with mineral additives. Filtration is

mechanically achieved by pumping water through a filter with tiny pores. Viruses and most bacteria are so small they pass right through the filter pores. They must be killed by chemical actions; i.e. chlorine. Both sanitation and filtration are necessary for water clarity. Maintaining the correct pH and mineral balance of the tub water will ensure a long life for the metal components exposed to water and reduce tub surface scaling.

IMPORTANT: Your HOT SPOT warranty specifically **excludes** surface or component damage caused by poor water chemistry, the improper use or application of chemicals, the use of non-approved chemicals, or the non-control of pH.

IMPORTANT: Any tub shell, plumbing, electrical system, thermal cover, or other component failure resulting from the addition of any **non-approved** alternate water sanitation or purification device, heating system or the modification of the original equipment is not covered by your HOT SPOT warranty.

WATER CHEMISTRY TERMINOLOGY

The following chemical terms will be used in this Water Quality and Maintenance Section. Understanding their meaning will help you to better understand the water maintenance process.

Bromamines: Compounds formed when bromine combines with nitrogen from body oils, urine, perspiration, etc. Unlike chloramines, bromamines have no pungent odor and are effective sanitizers.

Bromine: A sanitizer in the same chemical family as chlorine. Bromine is commonly used in stick, tablet, or granular form.

WARNING: See Note #3 in DOs and DON'Ts of Tub Water Maintenance for additional information.

Calcium Hardness: The amount of dissolved calcium in tub water. This should be approximately 100-200 ppm. High levels of calcium can cause cloudy water and scaling. Lower levels can harm the equipment.

Chloramines: Compounds formed when chlorine combines with nitrogen from body oils, urine, perspiration, etc. Chloramines can cause eye irritation as well as strong odors. Unlike bromamines, chloramines are very weak sanitizers.

Chlorine: An efficient sanitizing chemical for tubs. Watkins Manufacturing Corporation recommends the use of "Sodium Dichlor" type granulated chlorine for sanitizing the water. This type is preferred as it is totally soluble and nearly pH neutral.

Chlorine (or Bromine) Residual: The amount of chlorine or bromine remaining after chlorine or bromine demand has been satisfied. This residual is, therefore, the amount of sanitizer which is chemically available (FREE CHLORINE) to kill bacteria and algae.

DPD: The preferred reagent used in test kits to measure and indicate Free Available Chlorine.

Halogen: Any of the five elements; fluorine, chlorine, bromine, iodine and astatine.

OTO: A test reagent used to measure total chlorine in tub water. OTO can't readily distinguish between Free Available Chlorine and Combined Chlorine, so it is less desirable than DPD.

pH: The measure of acidity and alkalinity. The recommended pH for tub water is 7.4 to 7.6. Below 7.0 (considered neutral), the tub water is acidic and can damage the heating system. Above 7.8 the water is too alkaline and can result in cloudy water and scale formation on the tub shell and heater.

ppm: An abbreviation for "parts per million," the accepted measurement of chemical concentration in tub water.

Phenol Red: A chemical reagent used in testing for pH.

Reagent: A chemical material in liquid, powder or tablet form for use in chemical testing.

Scale: Rough calcium-bearing deposits that can coat tub surfaces, heaters or plumbing lines, and clog filters. Generally, scaling is caused by mineral content combined with high pH and enhanced by hot water.

Super-chlorination: Also known as "shock treatment", Super-chlorination is a process of adding significant doses of a quick dissolving sanitizer ("dichlor" is recommended) to oxidize non-filterable organic waste and to remove chloramines and bromamines.

Total Alkalinity: The amount of bicarbonates, carbonates, and hydroxides present in tub water. Proper total alkalinity is important for pH control. If the TA is too high, the pH is difficult to adjust; if it is too low, the pH will be difficult to hold at the proper level. The desired range of TA in tub water is 125 to 150 ppm.

USE OF THE TEST KIT OR TEST STRIPS

The use of a test kit is absolutely essential for maintaining chemically balanced water. The test kit (a calibrated test block and reagents) allows you to test the water for chlorine levels, pH, and other measures such as total alkalinity. You should make these tests daily until user load is established, then several times weekly to be sure proper levels are maintained.

Test strips are also an acceptable (and the most convenient) method but are susceptible to heat and moisture contamination which will result in inaccurate readings. Test strips are an excellent "quick-check" method for your tub water.

When using the test kit method, a few simple precautions must be taken to ensure maximum efficiency and accurate test data:

1. Water samples for each test should be taken at least 18" below the surface of the water. Rinse the test cells before and after each use. Do not dispose of test samples in the tub water.
2. Test comparisons should be made in natural light.
3. Reagents should be replaced at least yearly to maintain accuracy of test results.
4. When adding drops of reagents, the bottle must be held vertically and the drops added slowly to insure correct quantities are administered.
5. All test reagents should be kept out of the reach of children.

CHLORINE TEST NOTE: Because of its accuracy, a "DPD" test is recommended by Watkins Manufacturing Corporation when checking the "FREE CHLORINE" residual in your tub.

Alternatives to the DPD test kit are four-function test strips and five-function test kits, OTO and Phenol Red Kits. A five-function test kit is a DPD kit plus reagents for testing total alkalinity and mineral content. An OTO test is slightly less reliable than the DPD test as it only measures the Total Available Chlorine level (free chlorine residual **and** combined chlorine).

Free Chlorine Test

1. Remove the stopper plug from the test block chamber marked either CHLORINE or CL.
2. With your finger tightly covering the CL chamber, dip the test block into the tub water. At a level approximately 18" below the water surface, remove your finger and allow the chamber to fill to the top line. Remove the test block from the tub water.
3. Place one **DPD #1** tablet in the filled CL chamber. Do not touch the tablet with your fingers as this may result in a false reading.

Super-Chlorination/Free Available Chlorine Test

To test for 10 ppm Free Available Chlorine using a test block that is only calibrated to 3.0 or 5.0 ppm, the following procedures should be followed:

FOR A TEST BLOCK CALIBRATED TO 3 PPM

1. In a glass, mix 1 test block full of tub water with 2 full test blocks of DISTILLED WATER.
2. Pour a portion of this water mixture back into the chlorine test block until it reaches the top line.
3. Follow steps 3 and 4 (Free Chlorine Test).
4. Match the color of the water sample to the calibrated test block color standards.
5. Multiply the chlorine level indicated by 3. Example: If the color standard indicates a level of 2.5 ppm then the Free Available Chlorine is 7.5 ppm. NOTE: To reach a level of 10 ppm, the water sample's color should be slightly darker than 3 ppm.

FOR A TEST BLOCK CALIBRATED TO 5 PPM:

1. In a glass, mix 1 test block full of water with 1 full of DISTILLED WATER.
2. Same steps as 2, 3, and 4 previously stated.
3. Multiply the chlorine level indicated by 2.

Total Alkalinity Test: The total alkalinity content of your tub water should be maintained in the 125 to 150 ppm range. Your HOT SPOT dealer can supply you with test strips or should be able to test the mineral content of the tub water for you.

HOT SPOT
STANDARD CHEMICAL
SANITATION PROGRAM

CHLORINE DPD TEST KIT OR TEST STRIP READING		DO NOT USE THE TUB UNTIL THE TEST KIT READING IS BELOW THIS LEVEL
5.0		RECOMMENDED LEVEL SAFE
4.0		
3.0		
ADD CHLORINE		
2.0		DO NOT USE TUB; ADD CHLORINE TO REACH RECOMMENDED SAFE LEVEL
1.0		
0		

pH: The pH of the tub water should be tested with a Phenol Red reagent and compared to the calibrated color standards on the test block.

**THE RECOMMENDED pH FOR YOUR
TUB WATER IS 7.4 - 7.6**

NOTE: The tub water should be allowed to stabilize for at least an hour prior to testing for pH.

	pH	
ALKALINE TUB WATER (SCALING ZONE)	8.2 7.8	ADD pH DECREASER TO LOWER pH
COMFORT ZONE IDEAL		
ACIDIC TUB WATER (CORROSIVE ZONE)	7.6 7.4 7.2 6.8	ADD pH INCREASER TO RAISE pH

ADDING TUB WATER CHEMICALS

IMPORTANT: ALL TUB WATER CHEMICALS MUST ALWAYS BE ADDED DIRECTLY INTO THE CENTER OF THE TUB WATER WHILE THE HYDROTHERAPY JET PUMP IS OPERATING ON HIGH SPEED.

This includes granulated Dichlor, granulated pH Increase or Decrease, granulated Total Alkalinity Increaser, liquid Stain and Scale Inhibitor, liquid Stain and Scale Inhibitor, liquid De-Foamer and any other type of approved spa/tub water chemical. (PREMIXING OF CHEMICALS IS NOT REQUIRED.)

To Administer Tub Water Chemicals:

1. Remove half of the thermal cover.
2. Push the button labeled "Jets" to get the hydrotherapy jet pump operational.
3. Carefully measure the recommended amount of tub water chemical and slowly pour it into the center of the tub water. (Refer to the Sanitation Table for dichlor amounts; follow the directions on the spa/tub chemical container for recommended amounts.) Use care not to splash chemicals on your hands, in your eyes or on the tub shell surface.
4. Replace and secure the thermal cover. Shut the hydrotherapy jet pump off after 10 minutes thus completing the application procedure.

IMPORTANT: "SUPER-CHLORINATE/SHOCK TREATMENT" NOTE: When administering a super-chlorination treatment to your tub water, it is advisable to open the thermal cover at least half way to allow the chlorine gas to vent off. This venting is extremely important as the concentration of trapped chlorine gas which may exist as a result of super-chlorination (not daily sanitation) may eventually cause degradation to the thermal cover seal.

Never leave an open tub unattended if children are present!

IMPORTANT: Granulated chlorine will degrade if stored improperly or for a long period of time. We recommend purchasing granulated Dichlor in one or two pound containers and storing it in a cool place to maintain the chlorine's freshness. Use care when handling.

CAUTION/WARNING: Watkins Manufacturing Corporation **does not** recommend the use of any type of floating chemical dispenser.

SANITATION

Chlorine

There are several forms of stabilized chlorine available for use in spas/tubs and swimming pools. Each form has specific chemical characteristics which makes it EXTREMELY IMPORTANT that you use the one specifically designed for small bodies of water such as a tub.

WARNING: Using the **incorrect** product such as Trichlor, which has a very low pH (2.6), dissolves very slowly, is highly concentrated, and was designed for concrete or plaster swimming pools—may cause damage to the HOT SPOT.

Watkins Manufacturing Corporation recommends ONLY "Sodium Dichlor" type granulated chlorine be used for sanitizing the water.

To maintain the minimum level, Sodium Dichlor type granulated chlorine must be added to your tub **daily**. It is also advisable to check the free chlorine residual regularly, especially just prior to use. It is important to note that a tub being used over an extended period of time, such as a whole afternoon or evening, will need chlorine added at least every hour or more frequently to maintain the **minimum** level of 2 ppm Free Chlorine Residual. The recommended **maximum** chlorine level when **using** your tub is 5 ppm or less.

In addition to maintaining your tub's Free Chlorine Residual in the 3 ppm-5 ppm range, a **weekly** "shock treatment" is required. When using a chlorine water sanitation system, the shock treatment is a process in which you add substantial amounts (see Tub Water Maintenance Schedule) of Sodium Dichlor to SUPER-CHLORINATE your tub water to a level of 10 ppm. This super-chlorination destroys chloramines and non-filterable organic wastes. After the super-chlorination, allow the chlorine level to drop below 5 ppm before using your tub.

If you use your HOT SPOT daily, the water should be SUPER-CHLORINATED to a level of 10 ppm at least once per week to oxidize chloramines and organic wastes.

As a final note, super-chlorination is recommended after refilling your tub each time. This process will kill any bacteria which may be present in the plumbing or may have entered the tub during non-use.

WARNING: Improper chemical maintenance may increase the risk of catching or spreading infection. Also, no one should be in the tub while chemicals are being added or are dissolving.

pH CONTROL

Maintaining proper pH is extremely important for sanitizer effectiveness, user comfort, and for preventing equipment deterioration. pH is the measure of acidity and alkalinity in the water. The proper level is 7.4 to 7.6. This level is not only considered safe for tub surfaces and equipment, but is a comfortable level for a tub user's skin.

If a pH is high (above 7.8), chlorine sanitizers are less effective, tub surfaces and equipment can scale, water may become cloudy, and filter cartridge pores may become obstructed. Correct this high pH condition by adjusting with a pH "decrease" additive.

Low pH (below 7.0) causes sanitizers to dissipate more rapidly, increases corrosion of equipment, and may make the water irritating to tub users. Adjust low pH by using a pH "increase" additive.

IMPORTANT: Tub water additives for pH control should **always** be added into the tub water while the jets are running. Failure to maintain proper pH will result in damage to various components, including the tub shell surface and may void your warranty.

TUB WATER MAINTENANCE SCHEDULE

RECOMMENDED SANITIZER	Sodium dichloro-s-triazinetrione, granular or Sodium dichloro-isocyanurate, granular (Common Name: Dichlor Chlorine, granular, 53%-65% available chlorine)
DAILY MAINTENANCE	Water Sanitation (average use) - Maintain level of 3-5 ppm free available chlorine residual. Add the recommended amount of dichlor (See Sanitation Table) <u>into</u> the tub water while the jet pump is operating. Run the jet pump for 10 minutes.
WEEKLY MAINTENANCE	<ol style="list-style-type: none"> 1. Test tub water pH; maintain pH in 7.4-7.6 range. Adjust as required. 2. Super chlorination (shock treatment) - Add the recommended amount of dichlor (See Sanitation Table) into the tub water while the jet pump is operating to raise the free available chlorine residual above 10 ppm. Run the jet pump for 10 minutes. Allow the free chlorine residual to drop to 5 ppm or below before using the tub! 3. Wipe off any "bath tub ring" using baking soda and a sponge. 4. Vacuum the tub using a Water Vac to remove any sand or debris from the floor.
MONTHLY MAINTENANCE	<ol style="list-style-type: none"> 1. Clean the filter cartridge 2. Clean tub shell, thermal cover, and tub skirt as required.
SANITATION TABLE	<p>Daily Chlorination - 3/4 - 1 tsp.</p> <p>Weekly Super-Chlorination - 2 - 3 tsp.</p>
IMPORTANT	<ul style="list-style-type: none"> • A tub being used over an extended period of time, such as a whole afternoon or evening, will need chlorine added at least every hour or more frequently to maintain the average level of 3-5ppm free chlorine residual. • The use of trichloro-s-triazinetrione (trichlor) for water sanitation or swimming pool acid (muratic acid) to lower pH could damage your tub and is therefore not recommended! • Keeping the thermal cover on and secured at all times (except when tub is used) will reduce chemical demand and help to maintain the tub's energy efficiency. • Always add all tub chemicals into the center of the tub water while the jet pump is operating on high speed. • Always test the tub water temperature with your hand to make sure it's comfortable before entering.
WARNING	Improper water chemistry or the use of non-recommended chemicals may cause severe damage to the tub surface or equipment which is not covered by the HOT SPOT warranty.

SUPPLEMENTAL WATER MAINTENANCE

Mineral Content

Proper mineral content is also an important factor in tub water. Total Alkalinity (TA) and Calcium Hardness (CH) are the two primary minerals which should be monitored. Total alkalinity is a measure of the buffering capacity of water, or its ability to resist a change in pH. Technically, total alkalinity is the total of carbonates, bicarbonates, hydroxides, and other alkaline substances in the water. When total alkalinity is too low, it will cause the pH level to fluctuate widely and can result in corrosive water. When total alkalinity is too high, the pH level will tend to be high (and difficult to lower) and may cause scale to form on the tub surface and equipment.

The recommended Total Alkalinity for your tub water is 125 to 150 PPM.

Low levels of calcium (water too soft) can lead to corrosion of equipment and staining of the tub shell surface. High levels of calcium can cause scaling of equipment and the tub shell surface.

Check with your HOT SPOT dealer for recommendations on controlling these mineral related problems.

Proper water sanitation and mineral balance (pH control) are ABSOLUTELY essential for a tub water maintenance program. The following points are optional:

Flocculating Agent

A flocculating agent consists of relatively large particles which when added to water attract very small particles to them like a magnet. These small particles will normally go through some cartridge filters. When they are attached to the flocculent particles, however, the combination is large enough to be trapped. The flocculent allows clarification of water contaminated with particles too small for some filters. Water sanitation is not improved by flocculating agents because with proper chlorination these small particles are rendered inert (biologically dead).

Mineral Deposit Inhibitors

As water evaporates from your tub, and make-up water is added, the amount of dissolved minerals that the tub water contains increases. The tub water will eventually become "hard" enough to damage the heater by calcifying the surface. Proper pH control can minimize this. Normal soap build-up demands water replacement regularly enough to where mineral depositing usually is not a problem. Keeping a lid on the tub will reduce evaporation substantially, and delay the water's hardening. Occasionally, high copper content or high iron content in the water may produce green or brown stains on the tub. In these cases, a mineral deposit inhibitor may be of help.

SERVICE NOTE: *Well water may contain high concentrations of minerals. The use of a low water volume, extra fine pore, water filter will help to remove many of the larger particles during the filling of the tub. These in-line, prefilters can usually be purchased at a hardware or plumbing supply store.*

IMPORTANT: Contact your local HOT SPOT dealer if you have a specific water chemistry problem or require assistance in developing a "tub care" program.

ACCESSORY NOTE: A Water Vac is available from your HOT SPOT dealer that can be used to remove sand and heavier debris from the floor of the tub. (See Appendix for additional information.)

TUB WATER MAINTENANCE Troubleshooting Guide

PROBLEM	PROBABLE CAUSE	SOLUTIONS
Cloudy Water	<ul style="list-style-type: none"> Inadequate filtration/dirty filter Excessive oils/organic matter Improper sanitation High pH and/or high alkalinity Suspended particles/organic matter Overused or old water 	<ul style="list-style-type: none"> Clean filter with a filter cleaner or degreaser. Shock the tub with chlorine (super-chlorinate). Increase sanitizer to recommended level. Adjust pH; add appropriate sodium bisulfate product. Use clarifier. Drain the tub, clean and refill.
Water Odor	<ul style="list-style-type: none"> Excessive organics/too many chloramines - insufficient free available chlorine Improper sanitation Low pH 	<ul style="list-style-type: none"> Shock the tub with chlorine. Increase sanitizer level to recommended level. Raise pH with sodium bicarbonate product.
Chlorine Odor	<ul style="list-style-type: none"> Too many chloramines - insufficient free available chlorine Low pH 	<ul style="list-style-type: none"> Shock the tub with chlorine. Adjust pH; raise pH with sodium bicarbonate product.
Musty Odor	<ul style="list-style-type: none"> Bacterial or algae growth 	<ul style="list-style-type: none"> Shock the tub with chlorine. If problem visible, draining and cleaning may be required.
Foaming	<ul style="list-style-type: none"> Buildup of body oils, lotion and chemicals resulting in soap or detergent Overused or old water Excessive organics 	<ul style="list-style-type: none"> Add defoamer, or drain and refill. Drain and refill Shock with chlorine.
Organic Buildup/Scum Ring Around The Tub	<ul style="list-style-type: none"> Body oils and dirt Inadequate filtration 	<ul style="list-style-type: none"> Wipe off scum with a clean rag. Depending on severity-drain tub, use a spa/tub surface cleaner to remove the scum, refill tub and adjust water. Clean filter with a filter cleaner or degreaser.
Algae	<ul style="list-style-type: none"> High pH Low free chlorine 	<ul style="list-style-type: none"> Shock with chlorine; adjust pH. Shock with chlorine; maintain sanitizer at recommended level.
Eye Irritation	<ul style="list-style-type: none"> Low pH Insufficient free available chlorine 	<ul style="list-style-type: none"> Raise pH with sodium bicarbonate product. Shock with chlorine.
Skin Irritation/Rash	<ul style="list-style-type: none"> Unsanitary/polluted water Chlorine level too high (above 5ppm FAC). 	<ul style="list-style-type: none"> Maintain recommended sanitizer residual at all times; super-chlorinate. Allow chlorine level to drop below 5ppm before using tub.
Stains	<ul style="list-style-type: none"> pH or total alkalinity too low drain and clean with appropriate product. High iron or copper in water 	<ul style="list-style-type: none"> Adjust pH and total alkalinity; use sequestering agent; drain and clean with appropriate product. Use sequestering agent for metals; adjust water.
Scale	<ul style="list-style-type: none"> Too much calcium dissolved in water-pH and total alkalinity too high 	<ul style="list-style-type: none"> Adjust total alkalinity and pH levels by adding the appropriate sodium bisulfate product; with concentrated scale deposits-drain the tub, scrub the scale off, refill the tub and balance the water.

CHEMICAL SAFETY AND STORAGE

When using chemicals, read labels carefully and follow directions precisely. Though chemicals protect you and your tub when used correctly, they may be hazardous in a concentrated form. Observe these guidelines:

1. Accurately measure and use the exact quantities specified, never more. Do not overdose.
2. Handle all containers with care. Store in a cool, dry, well ventilated place. (Not in tub's equipment compartment.)
3. Always keep chemical containers closed when not in use. Replace caps on proper containers.
4. Allow only a responsible person to handle tub chemicals. Keep them out of the reach of children.
5. Don't inhale fumes or let chemicals come in contact with your eyes, nose or mouth. Wash your hands after use.
6. Follow the emergency advice on the product label in case of accidental contact, or if the chemical is swallowed. Call a doctor or local Poison Control Center. If a doctor is needed, take the product container along so that the substance can be identified.
7. Don't let chemicals get on surrounding surfaces or landscaping. Don't use a vacuum cleaner to clean up chemical spills.
8. Don't smoke around chemicals. Some fumes can be highly flammable.

DOs AND DON'Ts OF TUB WATER MAINTENANCE

1. Many sanitizers, though of the same chemical family, have differing rates of solubility and pH. Their effectiveness could either be substandard or exceptionally harsh and damaging to the tub surface and equipment. For this reason:

DO NOT use "Tri-Chloro" granulated or tablet chlorine.

DO use Sodium Dichlor type granulated chlorine.

2. Many sanitizers may raise the level of total dissolved solids in water or are dangerous to handle. For this reason:

DO NOT use household bleach (liquid sodium hypochlorite).

3. Your HOT SPOT dealer may recommend a BROMINE tub water sanitation program. Whereas bromine and bromamines (the combined form of bromine) are effective sanitizers, the methods in which bromine administered to the tub water and the quality and composition of the product varies from each chemical manufacturer. The use of bromine sticks or tablets in floaters which may become entrapped on the seat (or sink to the floor) have shown to cause discoloration or surface distress to the PVC and ABS tub fittings. (The HOT SPOT tub shell can withstand the effects of Bromine except in instances where a floating dispenser becomes entrapped or if the dispenser is set on too high of a setting, thus creating an "over-bromination" or "high concentration" situation. In these situations, discoloration to the tub shell may occur.) In addition, automatic floating dispensers either have a tendency to "over" brominate or "under" brominate; as the rate of erosion varies greatly and must be monitored. For these reasons:

DO NOT use a bromine sanitation system as a low or no maintenance solution to your tub water sanitation program. If a bromine sanitation system is used, Quick-Dissolved Granulated Bromine is recommended. If a bromine sanitation system utilizing a floating dispenser is used (this method is **not** recommended by Watkins Manufacturing), carefully follow your authorized dealer's written instructions and discontinue its use immediately should signs of discoloration to the tub shell surface occur.

4. Many swimming pool water care products can cause damage to tub surfaces and equipment of smaller bodies of water such as spas and hot tubs. For this reason:

DO NOT use swimming pool (muriatic) acid to lower pH.

5. **DO NOT** store chemicals in the tub's equipment compartment.

VI. SERVICE INFORMATION

GENERAL INFORMATION

The HOT SPOT has been designed to provide years of trouble-free use. As with any appliance, problems may occasionally occur that require the expertise of a qualified service person. Though such simple repairs as resetting a high-limit thermostat or a G.F.C.I. may not require a service call, they may indicate that a more serious condition exists. These conditions may require an experienced service person. Before calling for service, please refer to the TROUBLESHOOTING GUIDE.

NOTE: Always retain your original sales receipt for future reference.

G.F.C.I. AND HIGH-LIMIT THERMOSTAT

If your tub fails to operate at any time, the following items should be checked:

1. Check the power supply to the tub.
2. Check the G.F.C.I. and see if it has tripped. If a G.F.C.I. has tripped, reset it. If it will not reset, this may be an indication of a ground fault (short circuit) within the electrical components. Contact an authorized service technician for a complete diagnosis.
3. If upon checking the G.F.C.I. you find that it has not tripped, check the house breaker panel and ensure the main breaker for the electrical circuit supplying the tub has not tripped. If it has, this is an indication that the circuit was either overloaded or a ground fault exists between the breaker panel and the tub receptacle. Contact a qualified electrician.
4. If upon checking the main house breaker and tub G.F.C.I. you find no failures, the heater high-limit thermostat should be checked. Tripping of the heater high-limit thermostat is always a result of one or a combination of any of these problems. 1) blockage within the system plumbing, 2) switch malfunction in the heater circuit, or 3) the low speed of the jet pump is not functioning (see Improper House Wiring). To check the heater high-limit open the equipment access panel and depress the red button labelled heater reset. If it has tripped you will hear a click when the switch resets. Push the "Jets" button to check the tub's operation.

5. If upon checking the Heater High-Limit Thermostat you find it has not tripped, the equipment protection circuit breaker should be checked. The circuit breaker is located on the front of the control box. Carefully push in the button to reset the breaker. If the breaker continues to trip, contact an authorized service technician for a complete diagnosis.

If the tub does not function and the G.F.C.I. and Heater High-Limit Thermostat have not tripped or the circuit breaker tripped, then the problem should be referred to a qualified service technician.

MISCELLANEOUS SERVICE INFORMATION

The control and high limit thermostat capillaries are not electrical wires. They are copper tubes with tiny bores which carry expansive fluid. NEVER cut, bend or kink them.

The jet pump is equipped with a thermal overload cutoff switch which is designed to protect the pump from overheating. If the pump shuts itself off in an older tub, it could indicate failure of the pump motor bearings. If the pump shuts itself off in a new tub, it is usually the result of one, or a combination of the following factors:

High Temperature: During the summer months, especially in warmer climates, the ambient temperature contributes to excessively high temperatures within the equipment compartment.

Friction: Sometimes the moving parts of a new pump are tight enough to cause heat build-up due to friction. After a normal break-in period, the pump will run cooler.

Improper House Wiring: If the tub is connected to an extension cord, and/or the house wiring is undersized, the pump may starve for voltage and therefore draw more amperage and generate excessive heat.

If the pump is shutting down due to excessive heat, make sure the equipment compartment has adequate ventilation. The air gap at the bottom must not be blocked. Should your jet pump continue to shut off after short periods of use, contact a qualified service technician.

The HOT SPOT is equipped with a safety suction spring valve which will break the prime of the jet pump if both suction fittings are obstructed.

EQUIPMENT REMOVAL AND INSTALLATION

The equipment skid pack of the HOT SPOT has been designed for easy removal by the homeowner should service be required. To remove the equipment skid pack:

1. Drain the spa.
2. Untie the vinyl skirt cord located at the base of the equipment compartment and unzip the zipper.
3. Pull both lower corners of the vinyl skirting upward and outward and secure them on top of the tub to expose the equipment access door.
4. Remove the five screws that hold the access door in place and remove the door.
5. Locate the two white plumbing compression unions that connect the heater and jet pump system to the tub. One is located in the upper left corner of the compartment between the heater and tub wall and the second one is located at the right side of the jet pump. Turn the union nut counterclockwise to disconnect the equipment skid pack from the tub.
6. Remove the two bolts that secure the skid pack to the floor of the equipment compartment.
7. Reach behind the control box and carefully pull off the 1/8-inch clear vinyl tubing from the air switch fitting.
8. Remove the equipment skid pack from the equipment compartment.

To reinstall, reverse the order in which the skid pack was removed.

IMPORTANT: Ensure there is a rubber O-Ring in the groove of the compression union before tightening. Check for leaks after filling the spa.

IMPORTANT SERVICE NOTE: If the equipment skid pack in your HOT SPOT does not look like the illustration on page 6 or the previous instructions do not correspond to your tub's equipment configuration, contact your authorized service center for supplemental instructions.

ACTS INVALIDATING WARRANTY

The warranty is void if the HOT SPOT has been installed incorrectly, subjected to alteration, misuse or abuse, or if any repairs on the tub are attempted by anyone other than an authorized representative of Watkins Manufacturing Corporation. Alteration is defined as any component or plumbing change, electrical conversion, or the addition of any non-approved sanitation or water

purification device or heating system which contributes to a component failure, unit failure or unsafe operating condition. Misuse and abuse shall include, any operation of the tub other than in accordance with Watkins Manufacturing Corporation printed instructions or use of the tub in an application for which it is not designed. Specifically: use of the tub in commercial application, damage caused by operation of the tub at water temperatures outside the range of 32 degrees F and 120 degrees F, damage caused by dirty, clogged or a calcified filter cartridge; damage to the tub surface caused by the use of Tri-Chloro chlorine, chemical tablets, acid, or any other tub sanitizing chemicals or tub surface cleaners which are not recommended by Watkins Manufacturing Corporation. Damage to components or tub surface caused by improper pH balance or other improper water chemistry maintenance; and damage to the tub surface caused by leaving the tub uncovered while empty of water and in direct exposure to sunlight (this may cause solar heating distress in desert or hot weather regions) are considered abuses and may invalidate this warranty.

DISCLAIMERS

Watkins Manufacturing Corporation shall not be liable for loss of use of the HOT SPOT or other incidental or consequential costs, expenses or damages, which may include but are not limited to the removal of a permanent deck or other custom fixture. Any implied warranty shall have a duration equal to the duration of the applicable warranty stated above. Under no circumstances shall Watkins Manufacturing Corporation or any of its representatives be held liable for injury to any person or damage to any property, however arising.

TROUBLESHOOTING GUIDE

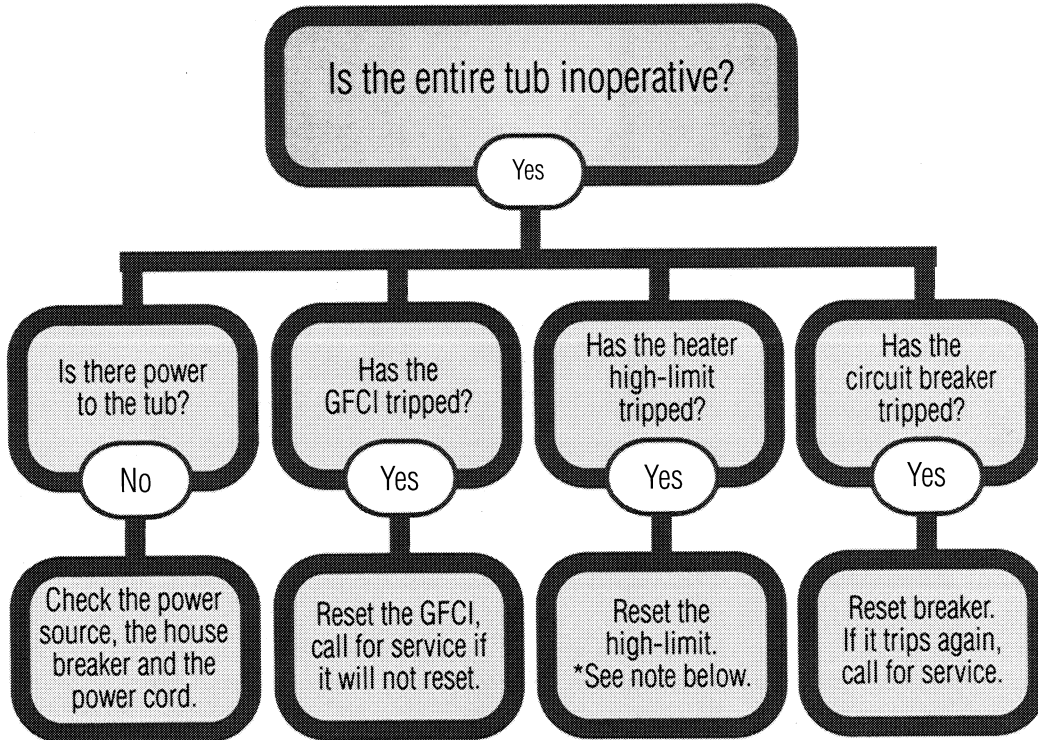

*If the high-speed pump was left running with the cover on the tub, the water was heated by friction.

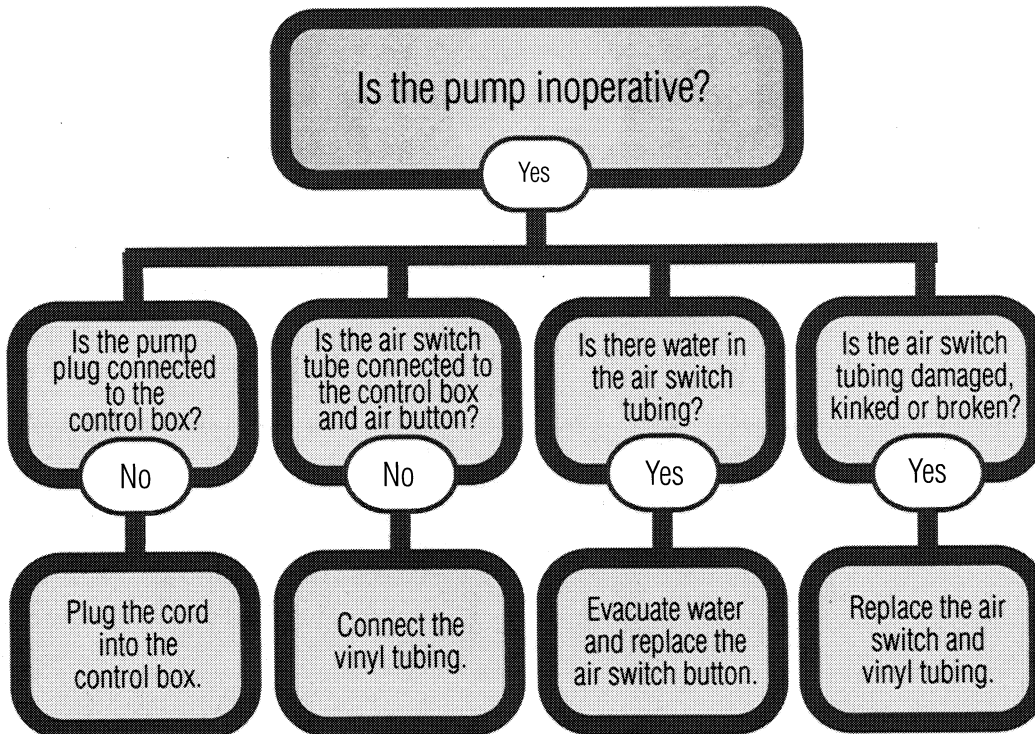

TROUBLESHOOTING GUIDE (CONTINUED)

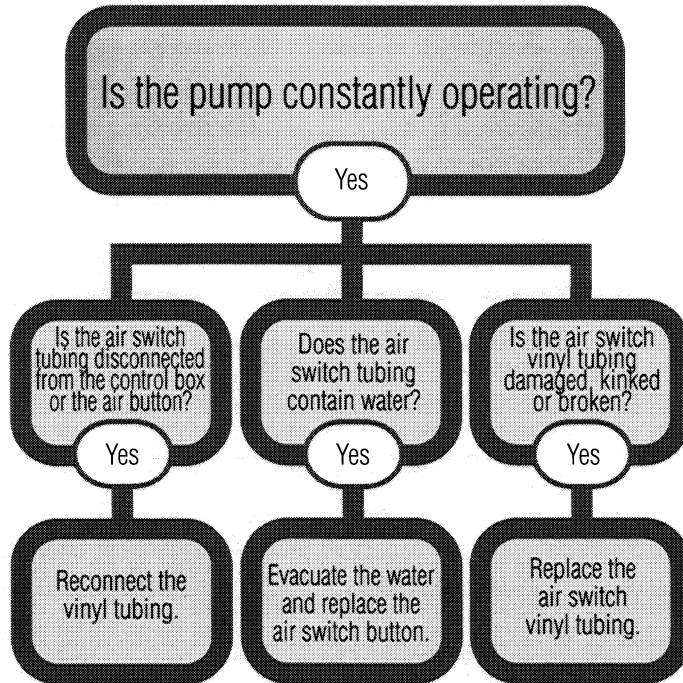
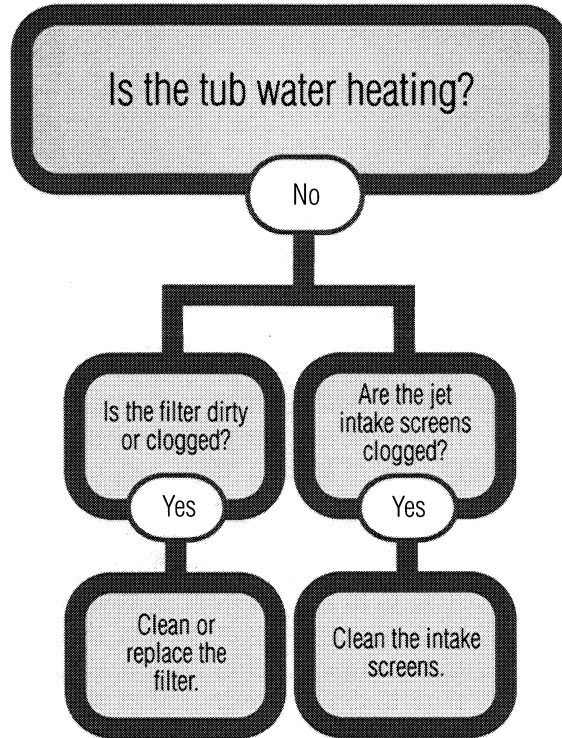

TROUBLESHOOTING GUIDE (CONTINUED)

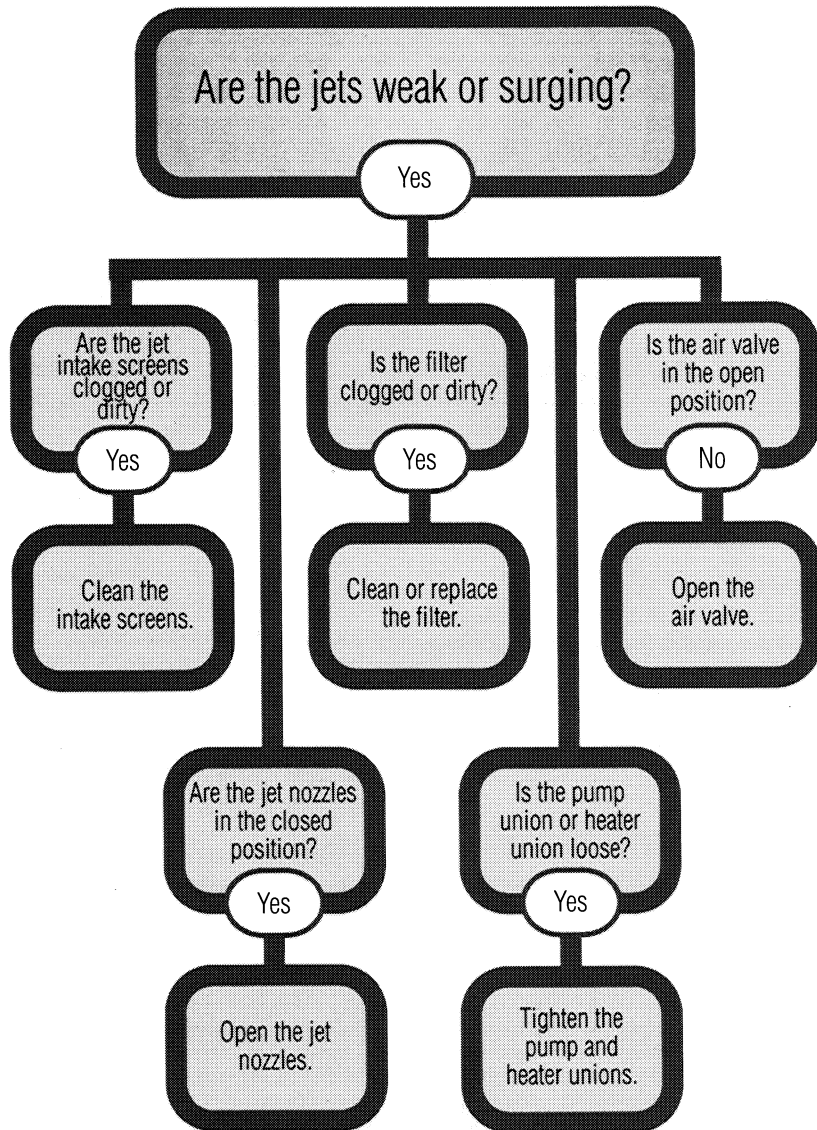

VII. APPENDIX

VINYL SKIRT REMOVAL AND INSTALLATION INSTRUCTIONS



The vinyl skirt of the HOT SPOT has been designed to be easily changed by the tub owner. The vinyl skirting is secured to the upper part of the tub with two sections of spline that are inserted into the skirt retainer (trim ring) around the tub perimeter. The bottom of the skirt is secured in place with a draw string. Two installers are recommended to install a new skirt on your HOT SPOT. The only tool required is a needle-nose pliers.

READ ALL INSTRUCTIONS BEFORE INSTALLATION

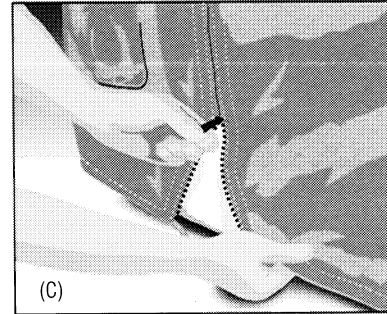
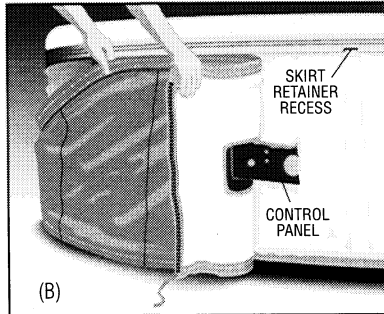
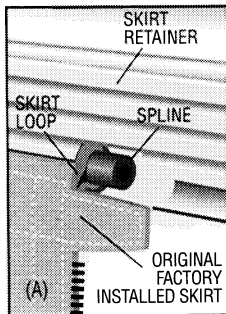

Vinyl Skirt Removal

1. Untie the draw string at the bottom of the vinyl skirt directly below the equipment compartment. Open the zipper and open the flap at the top to unhook the two zipper halves.
2. With a needle-nose pliers, carefully pull the spline out of each half of the skirt retainer (A). Use care not to damage the spline as it is reusable.
3. Gently pull the vinyl skirt loop out of the skirt retainer.

Vinyl Skirt Installation

1. Unroll the vinyl skirt and locate the control access flap, the top of the skirt (loop side) and the bottom of the skirt (draw string side).
2. To locate the starting point, first position the control access flap directly over the tub's control panel. Next, locate the recess in the skirt retainer (B).
3. While one person holds the skirt in this position, a second person should wrap the remaining skirt material around the tub and connect the two zipper halves. Close the zipper (C).

4. While one person inserts the skirt loop into the skirt retainer on the tub, a second person feeds the spline into the skirt loop to secure the left half of the skirt to the tub (D). **NOTE:** The tapered end of the spline should be inserted into the skirt loop.
5. Insert the right side skirt loop into the skirt retainer recess. Insert the spline into the skirt loop and continue feeding the spline into the loop until the skirt is completely secured in place (E).
6. Complete the skirt installation by tucking in the zipper flap at the top and tying together the bottom skirt cords (F).

Installation Tips:

1. The vinyl skirt should be stored at room temperature to ensure it fits perfectly when it's installed. A vinyl skirt will stretch up to an inch when it's hot and shrink approximately 1/2-inch when it's cold.
2. Should the material "bunch-up" when you are installing the second half, pull the spline half way out and firmly pull the wrinkle out of the skirt. Do not use excessive force when pulling on the vinyl.

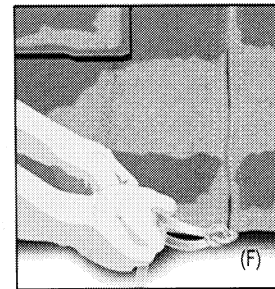
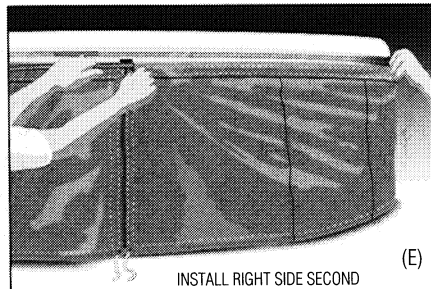
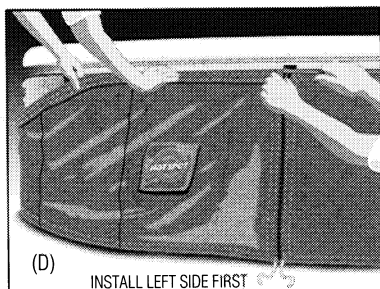

HOT SPOT COVER RESTRAINT INSTALLATION INSTRUCTIONS



WARNING: Watkins Manufacturing Corporation strongly recommends installing the cover restraint on your HOT SPOT if it is accessible by small children. The cover restraint should also be installed if the tub has been installed in a location that is subjected to freezing temperatures or to high winds which may dislodge the cover.

Tools Required:

Drill Motor
1/16" Drill Bit
Phillips-head Screwdriver

Installation Instructions:

1. Place the split-top thermal cover on the tub and orient it to your preferred position (See Illustrations A & B).
2. Connect the two buckles together and lay the cover restraint across the center line of the two cover halves (See Illustration C).
3. Insert a metal bracket through the looped end of the webbing. Place this metal bracket on the skirt retainer/trim ring in a level position approximately 5/8 of an inch up from the bottom of the strip (See Illustration D).

NOTE: To avoid possibly drilling into screw heads, the metal bracket should not be installed over the skirt retainer/trim ring splice cover.

4. Mark the two screw hole locations. Drill starter holes at each marked location with a 1/16" drill bit. Install the two stainless steel screws to secure the metal bracket to the tub.
5. Repeat the process on the opposite side of the tub.
6. Pull the restraining strap to adjust the cover restraint to a tight fit.

ILLUSTRATIONS:

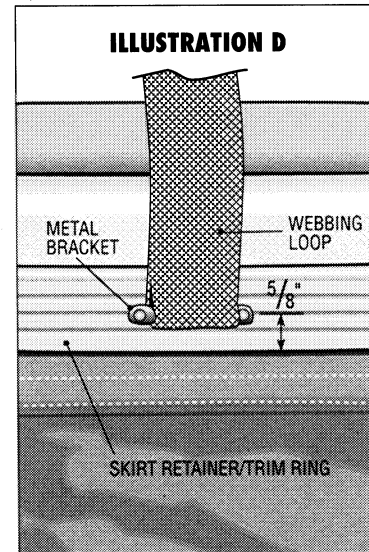
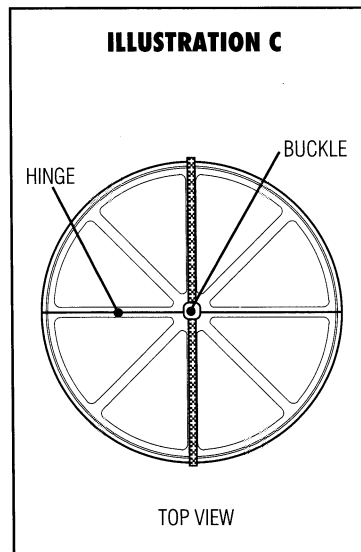
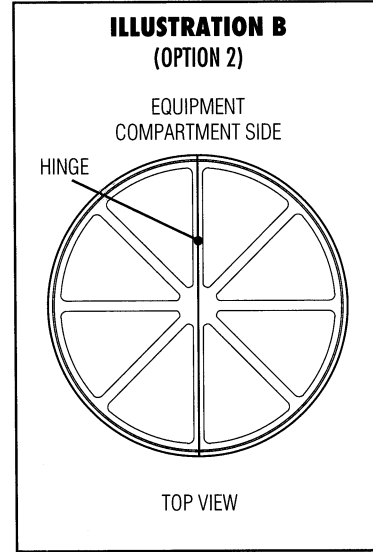
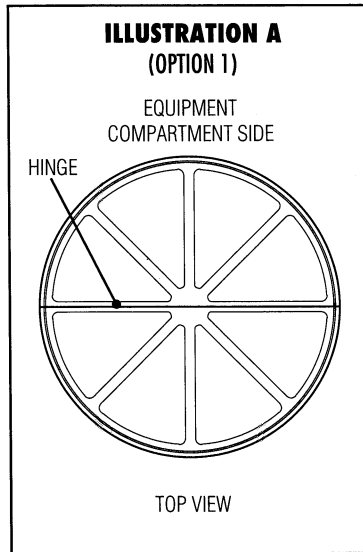

APPROVED ACCESSORIES AND TUB CHEMICALS

ACCESSORIES

- **WATER VAC**
The Water Vac is a multi purpose vacuum that connects to a common garden hose and easily removes sand and debris from the floor of the tub.
- **HYDROMASSAGE JET KIT**
The HOT SPOT stationary jets are interchangeable with a Pulse-Flo rotating jet. Installation tool may be required.
- **DUST COVER**
The HOT SPOT Dust Cover helps to keep the tub skirt and thermal cover clean during periods of time the tub is winterized or not used.
- **SPA PILLOWS**
Your dealer stocks HOT SPOT spa pillows which will add to your comfort during tub use.
- Your HOT SPOT dealer may also offer step kits or wood surrounds to customize your HOT SPOT installation. Contact your dealer for more information.

INTERCHANGEABLE VINYL SKIRTS

(Available Colors)

- SIERRA GRAY
- MISTY BLUE
- TROPICAL TEAL
- INDIGO BLUE
- WINE
- MIDNIGHT BLACK
- FOREST GREEN
- NAUTICAL BLUE
- SANDSTONE
- JAZZY PINK
- PURPLE GLO
- LASER BLUE

TUB CHEMICALS

SANITIZER

- Sodium Dichlor, granular, 53% - 65% available chlorine (sodium dichloro-s-triazinetrione, granular or Sodium dichloro-isocyanurate)

BALANCERS

- pH Increaser
- pH Decreaser
- Total Alkalinity Increaser
- Stain & Scale Control

ACCESSORY CHEMICALS

- Anti-Foam
- Water Clarifier
- Filter Cleaner/Degreaser
- Spa Shine Polish
- Cover Shield

WARRANTY SERVICE FORM

Please complete the following form when returning parts for replacement or repair:

Proof of purchase, such as a receipt or canceled check (or copies), is required for warranty service.

Name: _____

City: _____ State: _____ Zip Code: _____

Home Phone: _____ Work Phone: _____

Tub Serial Number: _____

Date of Purchase: _____

Place of Purchase: _____

Problem with Tub/Part (*Please give details*): _____

Allow 2 - 3 weeks for repair and return of your component.



WATKINS MANUFACTURING CORPORATION
VISTA, CALIFORNIA
U.S.A.

Warnock Hersey



This manual contains installation, operating, maintenance and service information for the following HOTSPOT models:

U.S.A. (Model Z) Canada (Model ZC)

Effective Date 6/94

© 1994 Watkins Manufacturing Corporation