

Owner's Manual



**Watkins
Manufacturing
Corporation**

**Congratulations on your decision
to enjoy the finest spas available...**

**Welcome to the growing family of
Hot Spot® Spa owners.**

Owner's Manual

This Owner's Manual will acquaint you with your new spa's operation and general maintenance. We suggest that you take some time to carefully review all six sections. Please keep this manual available for reference.

If you have any questions about any aspect of your spa's set-up, operation or maintenance, contact your authorized Hot Spot® Spa dealership. They are trained professionals who are familiar with the product as well as new spa ownership concerns. Their expertise will facilitate the enjoyment of your new Hot Spot® Spa.

The Serial Number/Identification label is located within the equipment compartment of your Hot Spot® Spa. The serial number should also be documented on the delivery receipt from your dealer.

IMPORTANT: Watkins Manufacturing Corporation reserves the right to change specifications or design without notification and without incurring any obligation.

DATE PURCHASED: _____

DATE INSTALLED: _____

DEALER: _____

ADDRESS: _____

TELEPHONE: _____

SPA MODEL/SERIAL NUMBER: _____

COVER SERIAL NUMBER: _____

In most cities and counties, permits will be required for the installation of electrical circuits or the construction of exterior surfaces (decks and gazebos). In addition, some communities have adopted residential barrier codes which may require fencing and/or self-closing gates on the property to prevent unsupervised access to a pool (or spa) by children under 5 years of age. Your Hot Spot® Spa is equipped with a locking cover that meets the ASTM F1346-91 Standard for Safety Covers and as a result, is usually exempt from most barrier requirements. As a general practice, your local Building Department will inform you of any applicable barrier requirements at the time a permit is obtained for the installation of an electrical circuit. Your Hot Spot® Spa dealer can provide information on which permits may be required.

The following instructions are required to be printed as a condition of the listing of this product. They contain important safety information, and we strongly encourage you to read and apply them.

IMPORTANT SAFETY INSTRUCTIONS

WHEN INSTALLING AND USING THIS ELECTRICAL EQUIPMENT, BASIC SAFETY PRECAUTIONS SHOULD ALWAYS BE FOLLOWED, INCLUDING THE FOLLOWING:

1. READ AND FOLLOW ALL INSTRUCTIONS.
 - 2A. **WARNING:** To reduce the risk of injury, do not permit children to use this product unless they are closely supervised at all times.
 - 2B. **DANGER: RISK OF CHILD DROWNING.** Extreme caution must be exercised to prevent unauthorized access by children. To avoid accidents, ensure that children cannot use a spa unless they are supervised at all times.
 - 3A. Connect only to a grounded, grounding type receptacle.
 - 3B. Do not bury the power cord.
 - 3C. **WARNING :** To reduce the risk of electrical shock, replace damaged cord immediately.
 4. **DANGER:** To reduce the risk of injury to persons, DO NOT remove suction fittings. (Never operate the spa if the suction fittings are broken or missing.)
 5. **DANGER: RISK OF INJURY.** The suction fittings in this spa are sized to match the specific water flow created by the pump. Should the need arise to replace the suction fittings or the pump, be sure that the flow rates are compatible.
 6. A ground terminal (pressure wire connector) is provided on the control box inside the unit to permit connection of a minimum No. 8 AWG (8.4 mm²) solid copper bonding conductor between this point and any metal equipment, metal water pipe, metal enclosures of electrical equipment, or conduit within five feet (1.5 m) of the unit as needed to comply with local requirements.
 - 7A. **WARNING:** Your spa is provided with a Ground Fault Circuit Interrupter for user and equipment protection. To ensure proper operation of this important safety device, test the breaker monthly, according to the following instructions per electrical configuration.
 - 7B. **Cord-Connected 115 Volt, 15 Amp Models:** The GFCI is located on the face of the equipment control panel (on the front of the control box). Before each use, with the unit operating, push the TEST button. The unit should stop operating and the RESET button should protrude. Push the RESET button. The spa should now return to normal operation. If the interrupter fails to operate in this manner, it is an indication of an electrical malfunction and the possibility of an electric shock. Disconnect the power until the fault has been identified and corrected.
 - 7C. **Hard-Wired 115 Volt, 30 Amp Models:** There are two GFCI breakers and locations used in the hard-wired models. The main GFCI location is inside the subpanel. The GFCI breaker inside the subpanel supplies all of the power to the spa. Before each use, open the subpanel and press the TEST button located on the subpanel GFCI breaker. The breaker should snap into the "tripped" position and the spa should stop operating. Reset the subpanel GFCI breaker by completely flipping the breaker switch down, into the off position. Then, flip the breaker switch up, into the on position. Power should be restored and the spa should resume operation.
The second G.F.C.I location is on the face of the equipment control panel (on the front of the control box). With the unit operating, push the test button. The spa should stop operating and the reset button should protrude. Push the reset button. The spa should now return to normal operation.
- Service Note:** "Hot" wires will exist in the control box when the control box GFCI is tripped in the 30 amp configuration. **DO NOT ATTEMPT SERVICE WITH POWER CONNECTED TO THE SPA.**
- If either the main or the secondary GFCI fail to operate in this manner, it is an indication of an electrical malfunction and the possibility of an electric shock. Disconnect the power until the fault has been identified and corrected.
8. Install the spa to provide drainage of the equipment compartment for the electrical components.
 9. **DANGER: RISK OF ELECTRICAL SHOCK.** Install at least 5 feet (1.5 m) from all metal surfaces. [A spa may be installed within 5 feet of a metal surface if each metal surface is permanently connected by a minimum No. 8 AWG (8.42 mm²) solid copper conductor attached to the wire ground connector on the terminal box that is provided for this purpose.] National Electrical Code ANSI/NMFA70-1993.
 10. **DANGER: RISK OF ELECTRIC SHOCK.** Do not permit any electrical appliances, such as a light, telephone, radio, or television within 5 feet (1.5 m) of a spa.
 - 11A. **WARNING: TO REDUCE THE RISK OF INJURY:**
 - 11B. The water in a spa should never exceed 104°F (40°C). Water temperatures between 100°F (38°C) and 104°F (40°C) are considered safe for a healthy adult. Lower water temperatures are recommended for extended use (exceeding 10 minutes) and for young children.
 - 11C. Since excessive water temperatures have a high potential for causing fetal damage during the early months of pregnancy, pregnant or possibly pregnant women should limit spa temperatures to 100°F (38°C).
 - 11D. Before entering a spa, the user should measure the water temperature with an accurate thermometer, since the tolerances of water temperature regulating devices may vary as much as ±5°F (3°C).
 - 11E. The use of alcohol, drugs or medication before or during spa use may lead to unconsciousness with the possibility of drowning.
 - 11F. Persons suffering from obesity or with a medical history of heart disease, low or high blood pressure, circulating system problems or diabetes should consult a physician before using spa.
 - 11G. Persons using medication should consult a physician before using a spa since some medication may induce drowsiness while other medication may affect heart rate, blood pressure and circulation.
12. SAVE THESE INSTRUCTIONS.

Table of Contents

I. GENERAL INFORMATION	2
Spa Specifications.....	4
II. INSTALLATION INSTRUCTIONS	
Site Preparation	6
Outdoor Installation	6
Deck Installation	6
Indoor Installation	6
Spa Levelling Instructions.....	7
Electrical Requirements	8
III. OPERATING INSTRUCTIONS	
Start-up Procedures	11
Heating and Hydromassage Systems	12
Equipment Control Panel	13
Spa Control Panel	14
IV. SPA CARE AND MAINTENANCE	
Draining the Water.....	14
Filter Maintenance.....	15
Care of the Exterior Finish.....	15
Vacation Care Instructions	16
Prevention of Freezing	17
V. WATER QUALITY AND MAINTENANCE	
General Information.....	18
Methods for Testing the Spa Water	18
Hot Spot® Spa Water Maintenance Program	19
Freshwater Ag+™ Silver Ion Purifier	21
Sanitation Chart.....	22
Silver Ion Sanitation.....	22
Freshwater Ag+™ Silver Ion Purifier Replacement.....	23
Chlorine (Sodium Dichlor)	24
Chlorine Maintenance Schedule.....	25
Common Water Chemistry Questions	26
Water Terminology	27
Troubleshooting.....	28
VII. SERVICE INFORMATION	
General Information.....	29
GFCI and High Limit Thermostat	29
Miscellaneous Service Information.....	29
Acts Invalidating Warranty	30
Disclaimers	30
Watkins Customer Service	30

I. GENERAL INFORMATION

PERSONAL SAFETY

Prolonged immersion in hot water can result in HYPERTHERMIA, a dangerous condition which occurs when the internal temperature of the body reaches a level above normal (98.6°F). The symptoms of hyperthermia include dizziness, fainting, drowsiness, lethargy, and a body temperature above 98.6°F. The physical effects of hyperthermia include unawareness of impending hazard, failure to perceive heat, failure to recognize the need to exit the spa, physical inability to exit the spa, fetal damage in pregnant women, and unconsciousness resulting in a danger of drowning.

WARNING: The use of alcohol, drugs, or medication can greatly increase the risk of fatal hyperthermia in hot tubs and spas.

Persons taking medications which induce drowsiness such as tranquilizers, antihistamines or anticoagulants should not use the spa. Pregnant women and persons with a medical history of heart disease, diabetes, or high blood pressure should consult a physician before using the spa.

Children are especially sensitive to hot water. At no time should children have unsupervised access to the spa. **Children must not be allowed to climb onto the spa cover.** All Hot Spot® Spas are equipped with a locking cover that meets the ASTM F1346-91 Standard for Safety Covers. Always lock the child resistant locks after using the spa for your children's safety.

DO:

- Be sure your spa is connected to the power supply correctly - use a licensed contractor.
- Disconnect the spa from the power supply before draining the spa or servicing the electrical components.
- Test the Ground Fault Circuit Interrupter(s) monthly.
- Test the water temperature with your hand before entering the spa to be sure that it's comfortable.
- Remember that wet surfaces can be very slippery. Take care when entering and exiting the spa.
- Use the cover when the spa is not in use, whether it is empty or full.
- Keep the water clean and sanitized with correct chemical care.
- Follow the Spa Care and Maintenance recommendations stated in this manual.
- Turn on the jet pump for at least ten minutes when adding ANY spa water chemicals into the filter compartment.
- Clean the filter cartridge monthly to remove debris and mineral buildup which may affect the performance of the hydromassage jets, limit the flow, or trip the high limit thermostat which will turn off the entire spa.

DON'T:

- Use the spa with the equipment compartment door removed.
- Use the spa for long periods of time at water temperatures in excess of 104°F.
- Allow the jet pump to operate for extended periods of time with the cover in place. Extended pump operation will cause a slow heat buildup due to water friction. The spa equipment controls are equipped with a built-in safety timer that will automatically shut off the jet pump after two hours of continuous operation should it have been left on inadvertently.
- Operate the spa at any time with the filter cartridge removed.
- Lift or drag the cover by using the tie-down straps; always lift or carry the cover by using the handles.
- Roll or slide the spa on its side. This will damage the skirt.
- Store chemicals in the spa's equipment compartment.
- Leave the Hot Spot® Spa exposed to the sun without water or the cover in place. Exposure to direct sunlight can cause solar distress of the shell material.
- Hesitate to call your Hot Spot® Spa representative with any questions or maintenance problems.

WARNINGS

The following warnings contain important safety information, and we strongly encourage you to read and apply them.

WARNING:

1. The vinyl cover is equipped with locking coverlocks. Watkins Manufacturing Corporation strongly recommends locking the cover if your Hot Spot® Spa is accessible by small children. The cover should also be locked if your spa installation site is subjected to freezing temperatures or to high winds which may dislodge the cover.
2. Use only approved accessories and recommended spa chemicals and cleaners.
3. Maintain proper water chemistry. The recommended levels for your Hot Spot® Spa are:

Free Available Chlorine (FAC):	3.0-5.0 ppm
Water pH:	7.4-7.6
Total Alkalinity:	125-150 ppm
Calcium Hardness:	150-200 ppm

(Refer to Water Quality and Maintenance section for complete instructions.)
4. NEVER use an extension cord to connect the Hot Spot® Spa to its power source. The cord may not be properly grounded and the connection is a shock hazard. An extension cord may cause a voltage drop, which will cause overheating of the jet pump motor and motor damage.
5. Do not attempt to open the electrical control box. There are no user serviceable parts inside. Opening of the control box by the spa owner will void the warranty. If you have an operational problem, carefully go through the steps outlined in the Troubleshooting section. If you are not able to resolve the problem, contact your authorized Hot Spot® Spa dealer. Many problems can easily be diagnosed over the telephone by a service technician.

SAFETY SIGN

Each Hot Spot® Spa is shipped with a SAFETY SIGN in the owner's package. The sign, which is required as a condition of Product Listing, should be permanently installed where it is visible to the users of the spa. To obtain additional SAFETY SIGNS, contact your Hot Spot® Spa dealer and request Part # 70798.

HOT SPOT RE AND RLX MODELS

SPA SPECIFICATIONS & ILLUSTRATIONS

HORIZONTAL DIMENSIONS:	78" (198 cm.) diameter round
HEIGHT (without cover):	29" (74 cm.)
EFFECTIVE FILTER AREA:	30 sq. ft. (2.79 sq. meters)
HEATER:	1000 watts (1.0 kW)
WATER (capacity):	230 gallons (871 liters)
WEIGHT:	200 lbs. dry (91 kg.), 2740 lbs. filled (1243 kg.)
DEAD WEIGHT (filled):	105 lbs. per sq. ft., 510 kg. per sq. meter
ELECTRICAL REQUIREMENTS:	115 volt 15 amp grounded circuit (standard) 115 volt 30 amp grounded circuit (optional—requires 30 amp subpanel)
NOTE:	30 amp wiring must be performed by a licensed electrician.
CERTIFICATIONS:	ETL Listed, Warnock Hersey Certified (Canada)

OVERHEAD VIEW

- A. Hydromassage Jets
- B. Light On/Off Switch
- C. Jet Pump On/Off Air Switch
- D. Hydromassage Jet Air Control Valve
- E. Jet Pump Anti-Suction Grill
- F. Light Lens
- G. Filter Compartment Cover

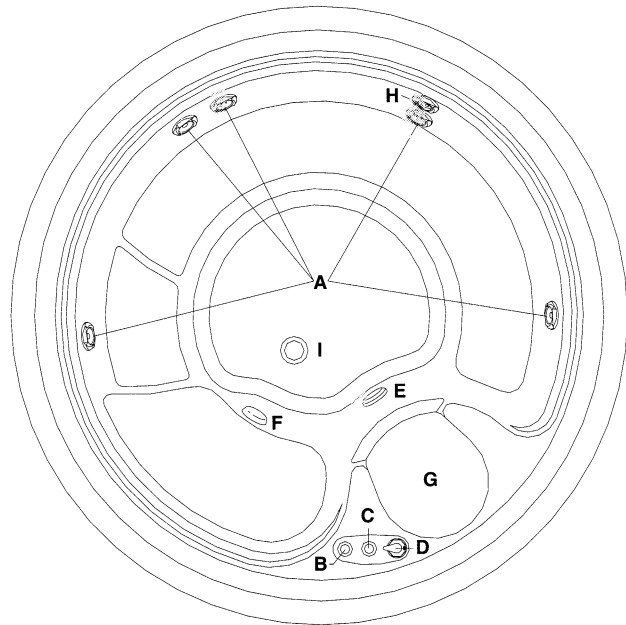

RLX model only

- H. Adjustable rotary hydromassage jet
- I. Floor Drain

EQUIPMENT COMPARTMENT

1. 1.0 kW Heater
2. Spa Drain Valve
3. Electrical control box
4. Compression Unions
5. Jet Pump
6. Jet Pump Vent

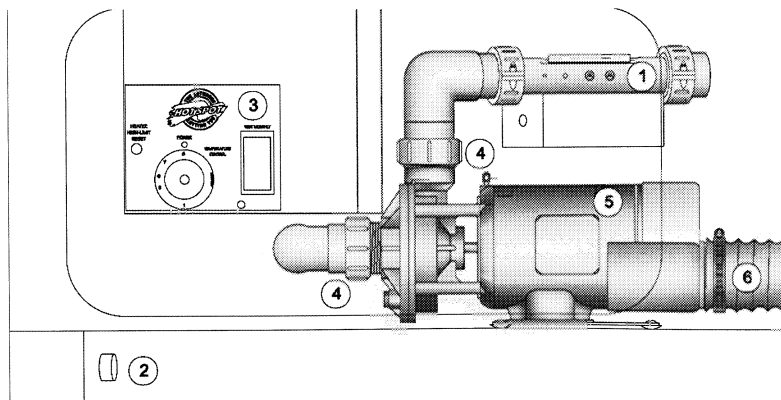

HOT SPOT SE AND SLX MODELS

SPA SPECIFICATIONS & ILLUSTRATIONS

HORIZONTAL DIMENSIONS:	78" (198 cm.) square
HEIGHT (without cover):	29" (74 cm.)
EFFECTIVE FILTER AREA:	30 sq. ft. (2.79 sq. meters)
HEATER:	1000 watts (1.0 kW)
WATER (capacity):	270 gallons (1022 liters)
WEIGHT:	250 lbs. dry (113 kg.), 3285 lbs. filled (1490 kg.)
DEAD WEIGHT (filled):	100 lbs. per sq. ft., 490 kg. per sq. meter
ELECTRICAL REQUIREMENTS:	115 volt 15 amp grounded circuit (standard) 115 volt 30 amp grounded circuit (optional—requires 30 amp subpanel)
NOTE:	30 amp wiring must be performed by a licensed electrician.
CERTIFICATIONS:	ETL Listed, Warnock Hersey Certified (Canada)

OVERHEAD VIEW

- A. Hydromassage Jets
- B. Light On/Off Switch
- C. Jet Pump On/Off Air Switch
- D. Hydromassage Jet Air Control Valve
- E. Jet Pump Anti-Suction Grill
- F. Light Lens
- G. Filter Compartment Cover

SLX model only

- H. Adjustable rotary hydromassage jet
- I. Floor Drain

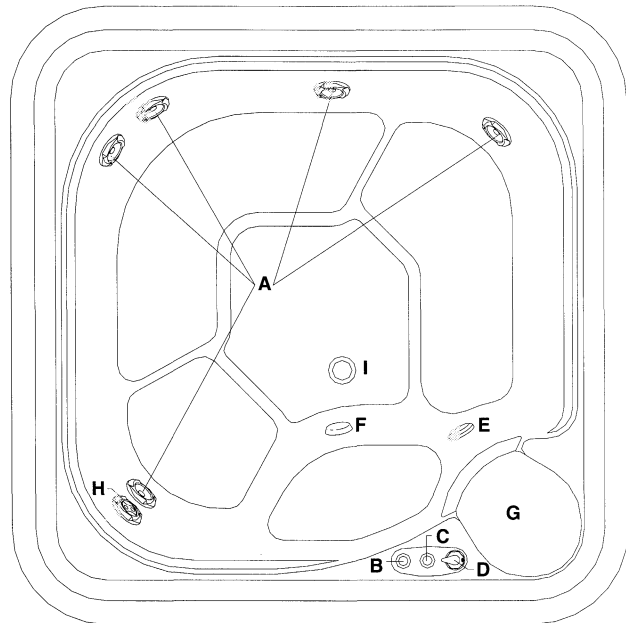

EQUIPMENT COMPARTMENT

- 1. 1.0 kW Heater
- 2. Spa Drain Valve
- 3. Electrical control box
- 4. Compression Unions
- 5. Jet Pump
- 6. Jet Pump Vent

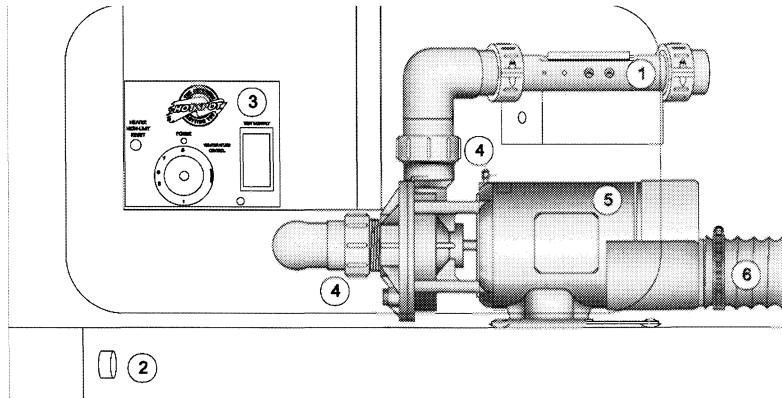

II. INSTALLATION INSTRUCTIONS

SITE PREPARATION

You probably have a spot picked out for your new spa, whether it's indoors or outdoors, on a patio or on a deck. Just make sure you check the following:

- Always put your spa on a structurally sound, level surface. A filled spa can weigh a great deal—as much as 120 pounds per square foot. Make certain that the location you choose can support the weight.
- Don't forget to level your spa before filling it. (See the Spa Leveling section of this manual)
- Be sure to locate your equipment compartment, which houses all of the electrical components, in a place where water drainage will be away from it. Allowing water into the equipment compartment can cause damage to the electronics, or may result in tripping the circuit breaker on your house's electrical panel.
- Leave yourself easy access to the Ground Fault Circuit Interrupter(s) (GFCI's) for monthly testing. GFCI's are located on the control box on all models, and there is an additional GFCI located inside the subpanel of a hard-wired (optional) 30 amp spa.
- Never let water into the subpanel (optional 30 amp models) or into the electrical outlet into which your spa is plugged. Your Hot Spot® Spa comes with a protective box designed to keep out rain and water from sprinkler systems. Your spa's subpanel is raintight when installed correctly with the door closed.
- Leave access to the equipment compartment for periodic spa care and maintenance.

OUTDOOR AND PATIO INSTALLATION

No matter where you put your new spa, it's important that it has a solid foundation to support it. In fact, structural damage to the spa resulting from incorrect installation or placement on an inadequate foundation is not covered under the spa's limited warranty.

If you install the spa outdoors, we recommend a reinforced concrete pad at least four inches thick. The reinforcing rod or mesh in the pad should be attached to a bond wire (see Safety Instructions, item 6).

If you place the spa on the ground, even temporarily, place stepping stones under the leveling areas (see Spa Leveling Instructions). The stones should be at least two inches thick and twelve inches square. Even with stones in place, the spa will inevitably settle and become unlevel. Plus, a spa surrounded by dirt or grass will soon be filled with dirt or grass from users' feet. So get it onto a solid foundation as soon as possible.

DECK INSTALLATION

To be certain your deck can support your spa, you must know the deck's maximum load capacity. Consult a qualified building contractor or structural engineer. To find the weight of your spa, its contents and occupants, refer to the Spa Specifications for your model. This weight per square foot must not exceed the structure's rated capacity, or serious structural damage could result.

INDOOR/BASEMENT INSTALLATION

Be aware of some special requirements if you place your spa indoors. Water will hit the floor around the spa, which can cause poor footing, so flooring materials should give your feet good grip when wet, and good drainage is essential. Water may also get into woodwork and produce dryrot, mildew, or other problems. The area's humidity will naturally be higher with the spa installed, so check for airborne moisture's effects on exposed wood, paper, etc. in the room. To minimize these effects and to make the room more comfortable, it is best to provide plenty of ventilation to the spa area. An architect can help to determine if more ventilation must be installed. Additionally, when building a new room for the spa, install a floor drain to allow easy cleanup of water and disposal of water when draining the spa.

Your Hot Spot® Spa dealer can help you with local information such as zoning regulations and building codes.

HOW TO UNPACKAGE AND MOVE THE HOT SPOT® SPA

The Hot Spot® Spa has been designed to be easy to move and install. For ease of handling, the spa should be moved as close as possible to the installation site before unpackaging.

CAUTION: Do not slide or roll the spa on its side, this will damage the skirt.

IMPORTANT REMINDERS:

- The Hot Spot® RE and RLX weigh 200 pounds and the Hot Spot SE and SLX weigh 250 pounds when in the factory packaging. At least two people are required to safely move and set down the spa.
- Do not roll or slide the spa on its side. Doing so may damage the skirt.
- Do not leave the spa exposed to the sun without water or the cover in place. Exposure to direct sunlight can cause solar distress of the shell material.

INSTALLATION NOTES:

1. If you are an owner of a condominium, town home/patio home or are a member of a homeowner's association, contact your representatives regarding their requirements. If you have any questions regarding zoning requirements or building codes, contact your local city government office.
2. **IMPORTANT:** The spa is designed for installation on a relatively flat and level surface. Installing the spa on an unlevel surface will result in unlevel water and an aesthetically unbalanced spa, but will not affect its performance. The spa may be shimmed according to the following Spa Leveling Instructions, however shimming of the spa may place additional stress on the spa's support system. Damage to the spa caused by the incorrect installation of the spa is not covered by the warranty.

Spa Leveling Instructions

Approved Shim Material [1/4" to 1/2" thick, cut into 2" x 4" rectangles (7 mm to 13 mm thick, cut into 5 cm by 10 cm rectangles)]

- Cedar Shingles
- Redwood
- Exterior Rated Plywood
- Exterior Rated Lumber

Suggested Leveling Procedure:

1. Using a six-foot carpenter's level (or a short level and a straight piece of wood about eight feet long), check the spa to identify the lowest and highest corners.
2. With one end of the carpenter's level resting on the highest corner of the spa, and the opposite end resting on the lowest corner, gently raise the lower end of the level with shims placed on the corner of the spa shell, until a level reading is achieved.
3. Carefully lift and pivot the carpenter's level (so as not to knock over your stack of shims) to each of the remaining corners. Place the required number of shims under the end of the level at each corner until a level reading is achieved. These are now your preselected shims.
4. Carefully remove the carpenter's level and the sets of shims. With one or more persons lifting the lowest side of the spa, place a 4" x 4" block under the spa base, in the center of the side lifted.
5. The Hot Spot® Spas may be shimmed only along the wooden base supports shown as shaded areas in the bottom view of each spa shown below. Set the preselected shim sets under the wooden base support at their designated leveling point for each corner. Lift the spa, remove the support block, and set the spa on the shims. Repeat this procedure for the opposite side of the spa, if necessary.
6. Use the carpenter's level to recheck the level of the spa.
7. Identify the locations of the remaining approved shimming points using the illustrations below, and carefully slide helper shims under the spa beneath each location. These helper shims should create a snug fit between the foundation and base support system. If it is necessary to lift the spa to place the helper shims, use care not to kick out the original corner shims.



Watkins Manufacturing Corporation recommends that the Hot Spot® Spa be installed above ground. Lowering the top of the spa to ground level, or employing decking which raises standing level toward the top of the spa substantially increases the hazard of accidental entry. Consult a licensed building contractor to design or evaluate your custom decking requirements.

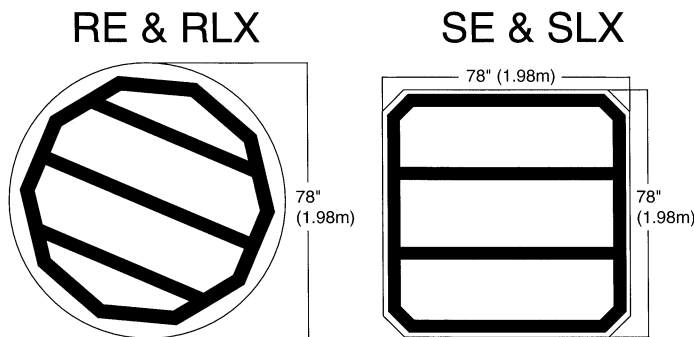

Electrical Requirements and Precautions

GENERAL INFORMATION

Your Hot Spot® Spa has been designed carefully to give you maximum safety against electrical shock. Connecting the spa to an improperly wired circuit will negate many of the spa's safety features. Please read and follow the electrical installation requirements and instructions for your specific spa model completely!

There are two electrical configurations associated with the Hot Spot® Spas. Each spa comes standard as a 115 volt 15 amp, cord-connected electrical configuration, which is designated as an "either/or" hydromassage system. This means that the heater will not activate simultaneously with the high speed mode of the jet pump. If you use your spa for extremely long periods of time with the high speed jet pump operating, you may experience a slight drop in water temperature. This happens because the heater will not heat while the pump is running on high. To allow the heater to operate at the same time as the high speed jet pump, the spa may be converted (by an authorized technician) to a 115 volt 30 amp hard-wired configuration. The 30 amp configuration provides enough electrical current to allow the heater and the high speed jet pump to operate simultaneously. Conversion requires electrical modification within the control box (contact an authorized Hot Spot® service technician) and the installation of an electrical subpanel (available from your Hot Spot® dealer). A licensed electrician must install the subpanel.

ELECTRICAL REQUIREMENTS

The spa must be connected to a 115 volt, 15 amp (30 amp for converted models) grounded circuit. The equipment pack requires a MINIMUM of 104 volts under load. A dedicated circuit is required; the term "dedicated" means the electrical circuit is not being used for any other high-load electrical items (patio lights, appliances, garage circuits, etc.). If the spa is connected to a non-dedicated circuit, overloading will result in "nuisance tripping" of the mini circuit breaker or of the breaker switch at the house electrical breaker panel.

The circuit must be properly wired; that is, it must have the following:

- Standard (cord-connected) 115 volt 15 amp – A minimum 15 amp circuit breaker in the house breaker panel, #14 AWG or larger wire (including the ground wire) and the correct polarity throughout the circuit.
- Converted (hard-wired) 115 volt 30 amp – A minimum 30 amp circuit breaker in the house breaker panel, #10 AWG or larger wire (including the ground wire), a subpanel with an appropriate GFCI breaker, and the correct polarity throughout the circuit.

A pressure wire connector is provided on the exterior surface of the spa's electrical control box, located inside the equipment compartment. This is to permit the connection of a bonding ground wire between this point and any metal equipment, enclosures, pipe or conduit within five feet of the spa (if needed to comply with local building code requirements). The bonding wire must be at least a #8 AWG solid copper wire.

NEVER CONNECT THE SPA TO AN EXTENSION CORD!

SPA INSTALLATION INSTRUCTIONS

Each Hot Spot® Spa comes equipped with approximately 15 feet of usable power cord (this is the maximum length allowed by regulatory standards and the National Electric Code). The power cord is stored for shipping inside the equipment compartment. To remove the power cord, open the equipment compartment and locate the cord. Carefully pull the cord out of the equipment compartment to the desired length.

If you choose to convert your spa to 115 volt 30 amp operation (contact an authorized Hot Spot® Spa service technician to perform the conversion), a licensed electrician must install the subpanel (available from your Hot Spot® Spa dealer). Refer to the 30 amp wiring instructions at the end of this section for electrical connections and specifications.

STANDARD, CORD-CONNECTED 115 VOLT 15 AMP CONFIGURATION

For your safety, if you are having an electrician install an electric outlet for the spa outdoors, it should be no closer than ten (10) feet and no farther than fifteen (15) feet from the spa. If the spa is being installed indoors, it should be no closer than five (5) feet and no farther than ten (10) feet from the spa. [Reference National Electrical Code 680 - 6a(1) and 680 - 41a.]

One GFCI is used in the cord-connected 15 amp configuration. The GFCI breaker is located on the front of the control panel. To test the GFCI, simply press the TEST button. The GFCI should trip to the off condition, disconnecting power to the spa. To reset the GFCI, press the RESET button. The GFCI should reset, and power should be restored to the spa. If the GFCI does not function in this way, unplug the cord and contact an authorized Hot Spot® Spa service technician.

CONVERTED 115 VOLT 30 AMP CONFIGURATION

Conversion Instructions

NOTE: An authorized Hot Spot® Spa technician must perform the conversion.

1. Disconnect power to the spa and access the control box.
2. Open the control panel and locate the program jumpers JP1: JP4 (on the main circuit board).
3. Using a pair of needlenose pliers, carefully install a jumper at location JP1 (refer to Figure 1).
4. Refer to Figure 2. Locate the 15 amp minibreaker. Follow each wire (black) from the load side of the minibreaker to determine which one is connected to the heater interlock relay.
5. At the minibreaker, disconnect the wire to the heater interlock relay (refer to Figure 3A).
6. Locate terminal L1 (hot) on the load side of TB-1.
7. Connect the heater interlock wire (black) to terminal L1 of TB-1 (refer to Figure 3B).
8. Refer to Figure 2. Locate the GFCI (inside the control panel). Follow each wire (white) from the load side of the GFCI to determine which one is connected to the heater interlock relay.
9. At the GFCI, disconnect the wire (white) to the heater interlock relay (refer to Figure 4A).
10. Locate terminal N (neutral) on the load side of TB-1.
11. Connect the heater interlock relay wire (white) to terminal N of TB-1 (refer to Figure 4B).

A licensed electrician must install the subpanel (available from your Hot Spot® Spa dealer) to supply power to the spa. The subpanel must be placed in sight of the spa, at a minimum distance of 5 feet away.

30 A Converted Configuration

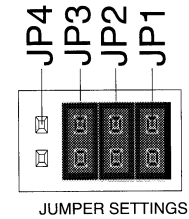

Figure 1

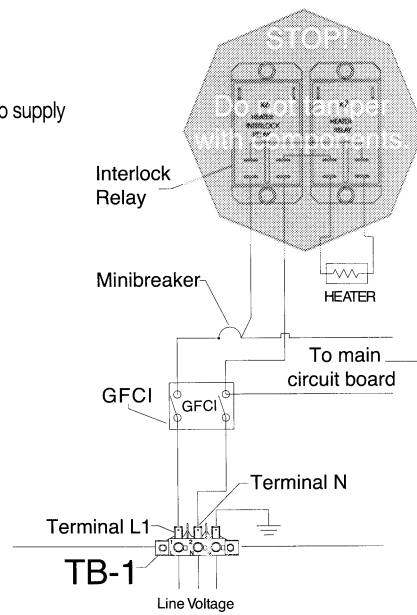

Figure 2

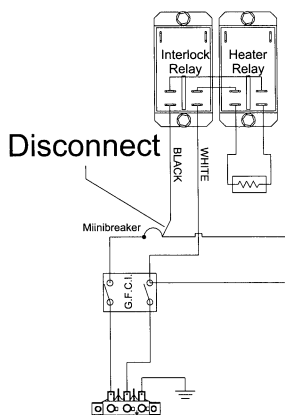

Figure 3

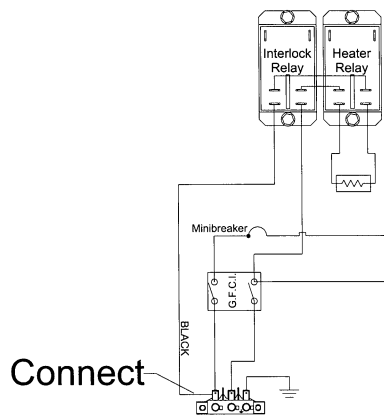

Figure 3B

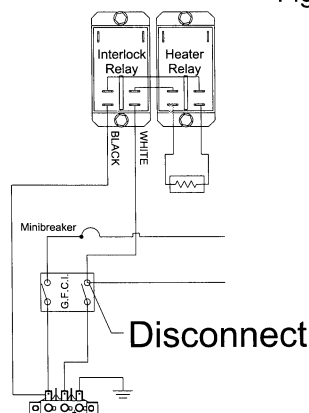

Figure 4A

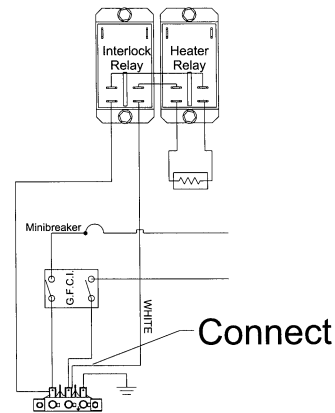

Figure 4B

30 Amp Subpanel Wiring Instructions

NOTE: The subpanel must be placed within 100 feet of the main electrical service panel, and between 5 and 50 feet away from the spa.

Refer to the wiring diagram below.

1. Connect the #10 AWG, WHITE [NEUTRAL] wire from the main electrical service panel to the subpanel NEUTRAL bar.
2. Connect the #10 AWG, GREEN [GROUND] wire from the main electrical service panel to the subpanel GROUND bar.
3. Connect the #10 AWG, BLACK [L1] wire from the main electrical service panel to the subpanel [terminal L1].
4. Check the connections internal to the subpanel and be sure that a pigtail wire exists between the neutral bar and the 30 amp breaker. NEVER remove the pigtail wires!
5. Inside the control panel, locate the terminal block (TB-1).
6. Connect the #10 AWG, BLACK wire from the subpanel 30 amp breaker [terminal L1] to TB-1 terminal L1.
7. Connect the #10 AWG, WHITE wire from the subpanel 30 amp breaker [terminal N, load neutral] to TB-1 terminal N.
8. Connect the #10 AWG, GREEN wire from the subpanel GROUND bar to TB-1 terminal GROUND.

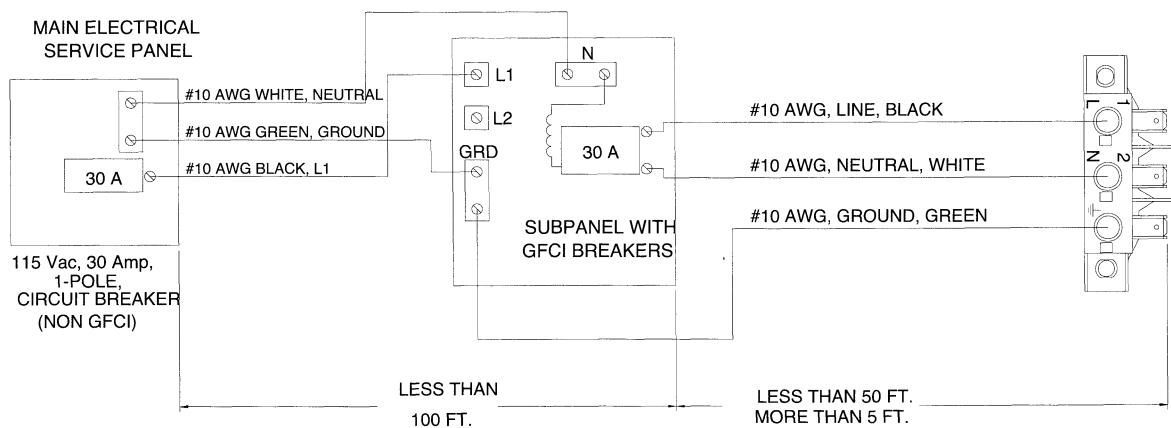

There are two GFCI locations used in the converted models. The main GFCI location is inside the subpanel. The GFCI breaker inside the subpanel supplies all of the power to the spa. Before each use, open the subpanel and press the TEST button located on the subpanel GFCI breaker. The breaker should snap into the "tripped" position and the spa should stop operating. Reset the subpanel GFCI breaker by completely pressing the breaker switch down, into the off position. Then, flip the breaker switch up, into the on position. Power should be restored and the spa should resume operation.

The second GFCI location is on the face of the equipment control panel (on the front of the control Panel). Once a month, with the unit operation, push the test button. The spa should stop operation and the reset button should protrude. Push the reset button. The spa should now return to normal operation.

SERVICE NOTE: "Hot" wires will exist in the control panel when the control panel GFCI is tripped in the 30 amp configuration. Do not attempt service with power connected to the spa.

If either the main or the secondary GFCI fails to operate in this manner, it is an indication of an electrical malfunction and the possibility of an electric shock. Disconnect the power until the fault has been identified and corrected.

IMPORTANT: Should you ever find occasion to move or relocate your Hot Spot[®] Spa, it is essential that you understand and apply its installation requirements. Your Hot Spot[®] Spa has been carefully engineered to provide maximum safety against electric shock. Remember, connecting the spa to an improperly wired circuit will negate many of its safety features.

III. OPERATING INSTRUCTIONS

START-UP PROCEDURES

Your Hot Spot® Spa has been thoroughly tested during the manufacturing process to ensure reliability and long-term customer satisfaction. A small amount of water may have remained in the plumbing after testing and, as a result, may have spotted the spa shell or the spa skirt prior to delivery. Before filling the spa, wipe the spa shell clean with a soft rag.

CAUTIONS

- Do not fill the spa with hot water, as tripping of the high-limit thermostat may result.
 - Do not connect power to an empty spa.
 - Before using your spa after filling, balance and sanitize the water. (See Water Quality and Maintenance Section.)
 - Watkins Manufacturing Corporation does not recommend the spa be filled with “softened” water.
1. Close the drain and fill the spa through the filter compartment with water.
HINT: Use the FreshStart™_{10,000} Pre-filter to remove unwanted contaminants from the tap water.
 2. **AFTER** the spa has been filled with water and the equipment compartment door is secured, power must be applied to the spa.
 - Standard 115 Volt 15 amp Models – Connect the plug to the house receptacle and push the Reset button on the GFCI.
 - Converted 115 Volt 30 amp Models – Open the door of the electrical subpanel and reset the GFCI breaker. Close and secure the subpanel door.
 3. The jet pump, heating system and all internal plumbing will achieve a partial prime during filling of the spa with water. To check the operation of the jet system and purge any remaining air from the equipment and plumbing, push the JETS button twice to make the jet pump run on high speed.
IMPORTANT: The air control which is located on the top of the spa shell and labeled AIR should be set to the ON position when checking jet operation. Always turn the air control to the OFF position anytime the spa is not being used. This will help to make the spa operate more quietly and heat more efficiently when the cover is in place.
SERVICE NOTE: Weak or surging jets are an indication of a low water level condition or a clogged cartridge filter.
 4. **IMPORTANT:** Adjust Total Alkalinity (TA), Calcium Hardness (CH), then spa water pH and finally sanitize the spa water following the procedures listed in the Water Quality and Maintenance Section. The jet pump should be on high speed for at least ten minutes and all chemicals added into the filter compartment.
OPERATION NOTE: Adjusting the Total Alkalinity as the first step is important, as out-of balance TA will affect your ability to adjust the pH correctly and will prevent the sanitizer from operating effectively.
 5. Once the spa water has been chemically balanced and sanitized, shut off the jet pump and turn the air control to the OFF position. Place the vinyl cover on the spa and secure it in place using the cover locks.
 6. Open the equipment access panel and turn the TEMPERATURE CONTROL on the control panel to number 7. Within 18 to 24 hours, the spa water will reach a temperature of approximately 100°F. A water temperature not exceeding 104°F can be achieved by setting the Temperature Control not higher than number 7-1/2 (halfway between #7 and #8). If you find that you prefer cooler water, rotate the temperature control toward the next lower number. If you prefer warmer water, rotate the temperature control toward the next higher number. Remember that a small change of the temperature control will yield a difference of several degrees, so make small adjustments until you find your preferred temperature. Allow several hours between adjustments. Thereafter, the water will remain within three degrees of your selected temperature. Please note, the numbers around the temperature dial are reference points to be used during temperature adjustments. They do not reflect the actual water temperature of the spa.

OPERATION NOTES:

1. The Hot Spot® Spa is equipped with a 10-minute timer delay on the heating/maintenance mode. Whenever the jet pump has been turned off (and a three-degree temperature drop has occurred) or the temperature control has been turned up, it will take 10 minutes before the low speed of the jet pump and heater become activated. Always push the JETS button to turn off the jet pump when exiting the spa. In the standard 115 volt 15 amp electrical configuration, the heating system does not operate simultaneously with the high speed pump. On the other hand, in the optional 115 volt 30 amp system, the heating system does operate simultaneously with the high speed pump.
2. The spa controller has an automatic two-hour “time-out” feature should the high-speed jet mode be left on inadvertently. After two hours of continuous operation, the controller will automatically return to the maintenance/heating mode.

HEATING AND HYDROMASSAGE SYSTEMS

The Hot Spot® Spa uses a two-speed jet pump to operate its hydromassage jets and to circulate the spa water through the heating system. The low-speed mode of the pump, which is activated automatically by the control thermostat, will cause the spa water to be drawn slowly in through the filter, the heater, and into the pump. The pump in turn will push the water back into the spa through the jets. When the JETS button is pushed one time, the spa user can activate the low speed of the jet pump. (The heater may or may not be on depending on whether the control thermostat has indicated a demand for heat.) When the JETS button is pushed a second time, the high speed of the jet pump will be activated. (This will automatically deactivate the heater if it is operating in a standard 15 amp system.)

In the optional 115 volt 30 amp electrical system, if a drop in the water temperature has occurred, the spa heater will operate simultaneously when the jet pump is operating on high speed. On the other hand, in a standard 115 volt 15 amp electrical system, the spa heater will not operate simultaneously when the jet pump is operating on high speed, even if a drop in the water temperature has occurred. In either electrical configuration, when the high-speed mode of the jet pump is turned off, the spa will enter a ten-minute “tranquil mode.” During this time the heating system (and simultaneous operation of the jet pump at low speed) will not operate (unless the JETS button is pushed), even if water temperature has dropped below the control setting. Once the 10-minute period has expired, the spa controller will switch to the maintenance mode and the heating system will be automatically activated.

The Hot Spot® Spa is equipped with a state-of-the-art heating system. The system uses an exclusive “flow through” No-Fault® 1000 stainless steel, high watt density heater that is practically impervious to scaling and corrosion (the two major causes of heater failure).

IMPORTANT: The 115 volt electrical system of the Hot Spot® Spa is not convertible to a 230 volt system. Any modification to the original equipment will void the spa’s ETL Listing, result in an unsafe spa and void the spa’s warranty!

CIRCULATION CYCLE SWITCH

The circulation cycle switch is primarily used when the ambient temperature remains high for extended periods of time. In this scenario, the heater may not cycle on because the spa water temperature does not cool. If the heater does not cycle on, the low speed jet pump will not automatically engage. This is very critical when using the FreshWater_{Ag+}™ Silver Ion Purifier, which relies on circulation to disperse silver ions throughout the spa. When engaged, the circulation switch will activate the low speed jet pump for a four-hour circulation cycle. If, during the circulation cycle, a user enters the spa and turns on the high speed jet pump, the circulation cycle will pause. When the high speed pump is shut off, the circulation cycle will resume (from the point in the circulation cycle when the high speed was initially engaged) to completion.

The circulation cycle begins when the switch is initially switched into the ON position. Thereafter, the circulation cycle will repeat for the same time every day until the switch is shut off. The only exception occurs in the event of a power failure. If power is disconnected from the spa when the circulation switch is in the ON position, the circulation cycle will reset and engage when power is reapplied. Therefore, if you have turned your switch on at 8 am, the low speed jet pump will be activated from 8 am to noon. The cycle will repeat the next day (at 8 am) as long as the switch remains on. However, if a power failure occurs at 10 am, then power is reapplied at 10:30 am, the cycle will reset and the low speed jet pump will activate from 10:30 am to 2:30 p.m.

To activate the circulation timer:

1. Determine the time of day at which you would like the pump to activate the circulation cycle. It is best to choose the cooler hours of the day, such as morning or evening.
2. Locate the circulation switch on the control panel.
3. At the time you have chosen as the start of your cycle, turn the circulation switch to the ON position. The low speed jet pump should activate and remain on for four hours.

NOTE: The circulation switch should remain off except in conditions where the ambient temperature remains very high for extended periods of time.

HYDROMASSAGE JETS

- A. On the Hot Spot® RE and SE models, the hydromassage jet nozzles are directional. The intensity of these jets is determined by the volume of air which is introduced into the jet chambers, where it mixes with the water stream. The air control valve is used to change the intensity of all five jets simultaneously. The intensity of individual hydromassage jets cannot be adjusted separately.

ACCESSORY NOTE: Your Hot Spot® Spa dealer stocks Micro’ssage Rotating Jet kits which can be installed easily in your spa in place of directional nozzles to vary the effects of the jets.

- B. On the Hot Spot® SLX and RLX models, the hydromassage jet nozzles are directional. The intensity of these jets is determined by the volume of air which is introduced into the jet chambers, where it mixes with the water stream. The air control valve is used to change the intensity of all six jets simultaneously. Each jet is also individually adjustable; simply turn the faceplate clockwise to decrease the jet pressure or counterclockwise to increase the jet pressure.

Directional / Rotary “Adjustable” Jet (Deluxe Models)

In the Hot Spot® SLX and RLX models, five of the six hydromassage jets contain directional nozzles, while the remaining one contains a dual port rotary nozzle. The directional nozzles and dual port rotary nozzle can be placed in any jet location desired. The nozzles can be removed by grasping the nozzle and gently pulling away from the jet faceplate. To install a new nozzle, align the four prongs on the rear of the nozzle with the four holes in the interior of the jet faceplate and press the nozzle into place. The nozzle will snap into place.

ACCESSORY NOTE: Additional Rotary Jet kits are available from your Hot Spot® Spa dealer.

EQUIPMENT CONTROL PANEL

The electrical control panel is one of the three major electrical components in the equipment compartment. Like the jet pump and heater, the electrical control panel contains no user serviceable parts. DO NOT open the electrical control panel as it will void the warranty. The operation and function of each of the switches and controls on the front of the control panel is explained as follows:

- A. **GFCI:** The Ground Fault Circuit Interrupter is a safety device that is designed to sense as little as 5 milliamps of electrical current leakage to ground. It is very important to protect a GFCI from rain and other moisture. Watkins Manufacturing Corporation recommends that the GFCI be tested monthly to ensure it is functioning correctly.

To test the Control Panel GFCI:

Once a month, with the spa operating, push the TEST button (located on the GFCI on the front of the control panel). The spa should stop operating and the RESET button should pop up. Reset the GFCI by pushing the RESET button. The spa will now operate normally. If the interrupter does not perform in this manner, it is an indication of an electrical malfunction and the possibility of an electric shock. Unplug the spa until the fault has been identified and corrected.

NOTE (Converted 115 volt 30 amp models only): Be sure to test the subpanel GFCI in addition to the control panel GFCI. For instructions on how to test the subpanel GFCI refer to the Electrical Requirements, Spa Installation Instructions.

- B. **HEATER HIGH-LIMIT SWITCH:** The heater high-limit thermostat sensor is located on the heater assembly. If for any reason the internal temperature of the heater exceeds 120°F, the red RESET button on this switch will trip and turn off the spa. This switch is described as “trip free”; that is, it cannot be reset or the circuit closed by physically holding in the button, until the sensor cools to approximately 110°F. The cause of the overheating must be located to prevent a recurrence. The most common cause of limit-tripping is inadequate water flow through the heating system. This may be caused by an obstruction within the pump water lines (filter, pump intakes or internal plumbing), the non-function of the low-speed mode of the jet pump, or the malfunction of the control thermostat. Once the cause has been identified and corrected, and the sensor has cooled, reset the switch.
- C. **TEMPERATURE CONTROL:** The temperature control is used to regulate the water temperature of the spa. As stated in the Start-Up Procedures, a water temperature of approximately 104°F can be achieved by setting the dial not higher than number 7-1/2. Please note, the numbers around the dial are reference points to be used during temperature adjustments. They do not reflect the actual water temperature of the spa. Once the dial has been set and the water temperature stabilized, the water will stay within three degrees of your selected temperature. Due to the limited accuracy of most thermometers, measuring the temperature drop with a household thermometer can be very difficult.

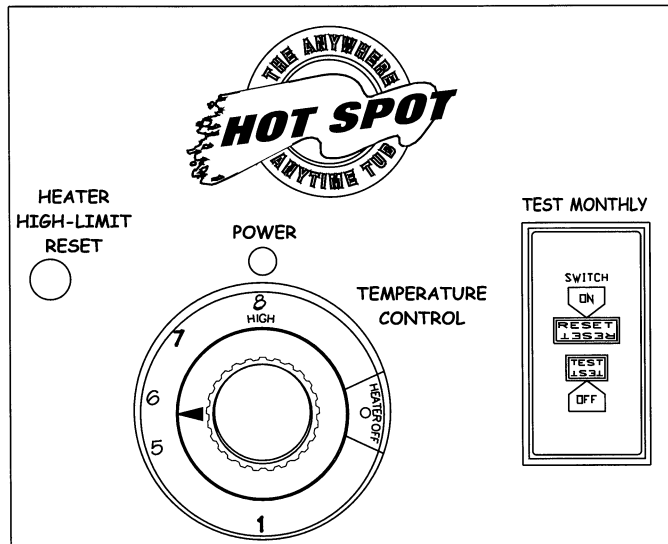

- D. **CIRCUIT BREAKER:** All Hot Spot® Spas are equipped with a 15 amp “mini” circuit breaker for protection of the equipment in the event of a circuit overload within the spa controls and to preclude reliance on the house circuit breaker. If the circuit breaker “trips,” identify and correct the cause and reset the breaker (see Troubleshooting Guide).
- E. **POWER-ON INDICATOR:** For your convenience, the control box incorporates a power-on indicator, which, in addition to showing the spa has power to it, provides a diagnostic function as well. A steadily illuminated indicator light means the spa is functioning properly electronically. An unlit indicator light means the GFCI or “mini” circuit breaker has tripped or power to the spa has been interrupted. The indicator light will begin blinking if the spa temperature high-limit switch has tripped. If the indicator is blinking, refer to the Troubleshooting Guide to identify and correct the cause. The indicator will stop blinking once the problem has been corrected.

SPA CONTROL PANEL

- A. **HYDROMASSAGE JET AIR CONTROL VALVE:** Turning the air control to ON allows for the same volume of air to flow to all five (six on the deluxe models) jets simultaneously. On the Hot Spot® RLX and SLX models, the jet faceplate is then used to control the intensity of each jet. Always turn the air control to the OFF position any time the spa is not being used. This will help make the spa operate more quietly and heat more efficiently when the cover is in place.
- B. **JET PUMP– ON/OFF SWITCH:** The jet pump switch can be used to activate two different jet pump speeds. Pushing the JETS button once will activate the jet pump on low speed. Pushing it a second time will activate the high speed mode of the jet pump. Always push the JETS button to turn off the jet pump when exiting the spa.
- C. **LIGHT–ON/OFF SWITCH:** The Hot Spot® Spa is equipped with a low-voltage spa light. To activate the spa light, push the button that is located on the spa’s control panel and labeled LIGHT. Push it a second time to deactivate the spa light. For your spa enjoyment, a blue and a red lens cover has been included with the spa’s owner’s package. The original clear lens is not removable – a colored lens can be snapped over the clear lens to achieve the desired color.

IV. SPA CARE AND MAINTENANCE

GENERAL INFORMATION

Your Hot Spot® Spa is manufactured from the highest quality, most durable materials available. Even so, the spa care and maintenance program you develop will ultimately determine how long your spa and its individual components will last. Regular maintenance following the advice in this section will help you to protect your investment.

DRAINING THE WATER

Detergent residues from bathing suits and soap film from your body may gradually accumulate in your spa’s water. Normally, in about four months the water will become sudsy and should be replaced. Showering without using soap prior to entering the spa or using only the rinse cycle when laundering your bathing suit will help to reduce detergent residue in the spa water. **Important:** Remember to change your water every four months.

TO DRAIN YOUR SPA:

1. Disconnect the spa from the power supply by the appropriate method:
 - Standard 115 Volt 15 Amp Models** - Disconnect the power cord from the house receptacle.
 - Converted 115 Volt 30 Amp Models** - Trip both of the GFCI breakers located in the subpanel.
2. Remove the screws from the equipment access door and remove the door completely. Locate the main drain valve for the spa and remove the drain cap. Attach the inlet of a garden hose to the drain valve (to avoid flooding of the foundation surrounding the spa) and route the outlet of the hose to an appropriate draining area.
 - NOTE:** Spa water with a high sanitizer level may harm plants and grass.
3. Open the valve by turning the knob counterclockwise. The spa will drain almost completely by gravitational flow. Any remaining water should be removed by bailing with a soft plastic cup.
 - IMPORTANT:** All Hot Spot® Spa models will drain almost completely through the main drain valve. Use a soft plastic cup to bail any remaining water. Equipment such as the jet pump and heating system will drain. Any water remaining within the plumbing after draining will only need to be removed if the spa is being winterized.
4. When empty, inspect the spa shell and clean as required. (Follow the Care of the Exterior Finish instructions.)
5. Remove the filter cartridge and clean as required (see the Filter Maintenance section).
6. Replace the filter cartridge.
7. Close the drain valve and reinstall the drain cap.

8. Replace or close the equipment access door and replace the screws.
9. Refill the spa through the filter compartment BEFORE restoring power.

IMPORTANT: Always clean the filter cartridge each time the spa is drained for cleaning. Always sanitize and chemically balance the spa water after cleaning and refilling the spa.

FILTER MAINTENANCE

As with any water filtering system, the filter cartridge may become clogged, resulting in reduced water flow. In your Hot Spot® Spa, it is important to maintain a clean, unobstructed filtering system to ensure maximum performance from the jets. *Watkins Manufacturing Corporation recommends the filter cartridge be cleaned with a filter cleaner once every month.*

WARNING: Failure to maintain the filter cartridge in a clean, unobstructed condition will result in reduced water flow through the heater assembly that may cause the High Limit Thermostat or Heater Thermal Cut-off to trip. If this high limit or thermal cut-off trip occurs during sub-freezing temperatures and goes unnoticed, the spa water may freeze. Any damage to the spa (due to freezing) caused as a result of poor maintenance (stated under misuse or abuse in the Hot Spot® Spa Limited Warranty), will not be covered by your spa warranty.

DANGER: To reduce the risk of injury to persons using the spa, DO NOT use the spa with the filter cartridge or filter standpipe removed!

FILTER CARTRIDGE REMOVAL AND CLEANING

1. Remove and carefully set aside the filter compartment cover.
2. Remove any floating items from within the filter compartment.
3. Turn the filter retainer handle (located on the top of the filter cartridge) counterclockwise until the retainer can be removed from the filter standpipe.
4. Remove the filter retainer and cartridge.

SERVICE NOTE: Never remove the filter standpipe. Debris may find its way into the internal plumbing which may result in blockage. NEVER REMOVE SUCTION FITTINGS.

5. Always clean the filter using a filter degreaser to remove mineral and oil buildup. Simply soak the filter in the degreaser (according to the degreaser directions), then place the filter on a clean surface and spray until clean using a garden hose. It may be necessary to rotate the filter while spraying to remove any debris lodged between the filter pleats.
6. To reinstall the filter cartridge, reverse the order of steps in which it was removed. Do not overtighten!

CARE OF THE EXTERIOR FINISH

SPA SHELL

The Hot Spot® RE and SE models have a high quality Enduro® shell. The Hot Spot® RLX and SLX models have a high quality granite-like shell. Stains and dirt generally will not adhere to your spa's surface. Cleaning of the surface should be done with a non-abrasive, non-sudsing cleaner. Sodium bicarbonate (baking soda) can also be used for minor surface cleaning. A soft rag or a nylon scrubber should easily remove most dirt. Always thoroughly rinse off any spa shell cleaning agent.

Cleaning of the surface at the waterline to remove any body oil or "bathtub ring" can be done easily with baking soda and a soft sponge. When your spa has been drained for cleaning, the use of a spa/tub surface cleaner is recommended to clean the spa shell. The use of a soft rag, soft sponge or nylon scrubber should easily remove most dirt build-ups. Always thoroughly rinse off any spa shell cleaning agent. The use of a spa polish is recommended after the spa shell has been dried, to polish the surface.

SERVICE NOTES:

1. Iron and copper in the water can stain the spa shell if allowed to go unchecked. Your Hot Spot® Spa dealer stocks a Stain and Scale Inhibitor to use if your spa water has a high concentration of dissolved minerals.
2. The use of alcohol or any household cleaners other than those listed to clean the spa shell surface is NOT recommended. DO NOT use any cleaning products containing abrasives or solvents since they may damage the shell surface. **NEVER USE HARSH CHEMICALS!** Damage to the shell by the use of harsh chemicals is not covered under the warranty.
3. Your dealer may also stock products which can be used in your spa to help control "bathtub ring."

IMPORTANT: Some surface cleaners contain eye and skin irritants. Keep all cleaners out of the reach of children and use care when applying.

SPA SKIRT

The spa skirt of the Hot Spot® Spa is manufactured from Enduro®[®], a durable U.V.-resistant material. Even so, monthly cleaning and periodic conditioning is recommended to maintain its beauty. To clean and condition the skirt:

1. With a garden hose, lightly spray the skirt to rinse away and loosen any dirt or debris.
2. Using a large sponge or soft cloth, and using a very mild soap solution (1 teaspoon dishwashing liquid with 2 gallons of warm water), scrub the surface in a circular motion. Use care not to let the skirt dry with a soap film on it before it can be rinsed clean.
3. Lightly spray the spa skirt to rinse away the cleaning solution.

IMPORTANT: To avoid soap getting into the spa water, the spa cover should be left on the spa during cleaning and rinsing.

VINYL COVER

The Hot Spot® Spa uses a one-piece vinyl cover. The vinyl spa cover is an attractive, durable foam insulation product. Monthly cleaning and conditioning are recommended to maintain its beauty.

To clean and condition the vinyl cover:

1. Remove the cover from the spa and gently lean it against a wall or fence.
2. With a garden hose, spray the cover to loosen and rinse away dirt or debris.
3. Using a large sponge and/or a soft bristle brush, and using a very mild soap solution (1 teaspoon dishwashing liquid with 2 gallons of water) or baking soda (sodium bicarbonate), scrub the vinyl top in a circular motion. Do not let the vinyl dry with a soap film on it before it can be rinsed clean.

IMPORTANT: To avoid soap getting into the spa water, the spa cover should not be on the spa during cleaning.

4. Scrub the cover's perimeter and side flaps. Rinse clean.
5. Rinse off the bottom of the cover (use no soap), and wipe it clean with a dry rag.
6. To condition the cover after cleaning, apply a thin film of Cover Shield to the vinyl surface and buff to a high luster.

SERVICE NOTE: To remove tree sap, use cigarette lighter fluid (not charcoal lighter fluid). Use sparingly, and rinse with a saddle soap solution immediately afterwards, then wipe dry.

Important reminders:

- **DO** remove snow buildup to avoid breakage of the foam core from the additional weight of the snow.
- **DO** lock cover straps to secure the cover when the spa is not in use.
- **DO NOT** drag or lift the spa cover using either the flaps or the tie-down straps.
- **DO NOT** walk, stand, or sit on the cover.
- **DO NOT** place any hot items or objects that will magnify or conduct heat on the cover; foam core damage may result.
- **DO NOT** use any chemicals or cleaners except those recommended by Watkins Manufacturing Corporation or its Authorized Sales and Service Dealer.

IMPORTANT: Whenever the spa is not in use, it is essential that the cover be in place. When filled, this ensures effective temperature maintenance and economical operation. When empty, this prevents potential damage to the surface finish of the interior walls, which can result from the excessive heat of the sun. This type of damage is specifically excluded from warranty protection.

VACATION CARE INSTRUCTIONS

If you plan to be away, follow these instructions to ensure the water quality of your spa is maintained:

SHORT TIME PERIODS (3-5 DAYS):

1. Adjust the Total Alkalinity, Calcium Hardness and pH by following the instructions outlined in the Water Quality and Maintenance section.
2. Sanitize the water by following the shock procedures also listed in the Water Quality section. Make sure the air control is turned to the OFF position.
3. Lock your cover in place using the coverlocks.
4. Upon your return, sanitize the water by following the shock procedures, and balance the pH.

LONG TIME PERIODS (5-14 DAYS):

Prior to leaving:

1. At least one day before you leave, set the temperature to its lowest level. This setting should represent an approximate water temperature of 80°F (27°C).

IMPORTANT NOTE: Spa water oxidizers such as sodium dichlor chlorine maintain their level of effectiveness substantially longer in warm water (80°F, or 27°C) than in hot water (101°F to 104°F, or 38°C to 40°C).

2. Adjust the Total Alkalinity, Calcium Hardness and pH as required. Sanitize the water by following the shock procedures.

Upon your return:

3. Sanitize the water by following the shock procedures. Return the set temperature to its original setting. The spa water will be safe for you to use once the Free Chlorine Residual level has dropped below 5.0 ppm.

NOTE: If you will not be using your spa for an extended period of time (in excess of 14 days) and an outside maintenance service (or neighbor) is not available to assist with the water maintenance, draining or winterizing of the spa is recommended.

PREVENTION OF FREEZING

Your Hot Spot® Spa has been designed and engineered for year-round use in any climate. In some areas, extremely cold temperatures (below 10°F) combined with strong wind may cause partial freezing of the jet pump, even though the water inside the spa remains at the selected temperature. The energy efficiency of the spa may also decrease during these cold periods, as the heater will cycle more frequently. As an additional precaution against partial freezing of some of the components, the equipment compartment door can be insulated with a fiberglass insulation blanket (available from your Hot Spot® Spa dealer). This additional insulation will also help to maximize the spa's energy efficiency.

NOTE: When warmer weather returns (approx. 60°-70°F), the insulating blanket must be removed to prevent overheating of the jet pump.

Please contact your Hot Spot® Spa dealer for additional information or to order the insulation blanket.

WINTERIZING

1. To winterize the spa, first perform the Draining the Water instructions mentioned at the beginning of this section. Then:
2. Remove the filter cartridge, clean and store in a dry place. Clean the filter compartment cover as well.
3. Wipe the inside of the spa and filter compartment completely dry.
4. To ensure the internal plumbing has drained completely and to remove any water that may be remaining in the jet pump, a wet/dry shop vac can be used at the spa drain. If you do not have access to a wet/dry shop vac, carefully lift the side of the spa (opposite the equipment compartment) approximately one foot off the ground to assist in drainage. If necessary, use a soft plastic cup to bale remaining water from the spa. Once you are sure the internal plumbing has drained completely, set the spa flat again. Leave the drain valve open during winterizing months.
5. On standard 115 volt 15 amp models, coil the power cord and place it in the equipment compartment. On converted (hard wired) 30 amp models, make sure that the GFCI breaker inside the subpanel remains in the OFF position during the winterization months.
6. Place the cover back on the spa and secure. Cover the vinyl cover with large board to distribute the weight from snow and ice.

SERVICE NOTES:

- Leave the main drain valve open approximately 1/4 turn during the winterizing months.
- You may wish to remove the filter standpipe to facilitate draining of the filter compartment.

NOTE: Remove any debris present on the floor of the filter compartment prior to removal of the filter standpipe (debris may enter the plumbing and block the lines). When replacing, do not overtighten.

To Reactivate:

Reinstall the filter cartridges, close the main drain and reinstall the drain caps. Follow the Start-Up Procedures to make your Hot Spot® Spa operational.

IMPORTANT: Always keep spa covered when not in use (empty or full).

V. Water Quality And Maintenance

It's important to have clean water. Water maintenance is one of the least understood, yet an important area of spa ownership. Your dealer can guide you through the process of achieving and maintaining perfect water in your spa, given your local conditions; here is our suggested step-by-step program.

Your program will depend on your water's mineral content, how often you use your spa, and how many people use it.

Watkins has developed a water care system for its spas, which is an alternative to using an entirely chlorine-based system. This system uses silver ions and an active sanitizer (monopersulfate, also known as MPS) to sanitize the spa. It includes the FreshStart™ 10,000 Pre-filter and the FreshWater_{Ag+}™ Silver Ion Purifier.

GENERAL INFORMATION

THE THREE FUNDAMENTAL AREAS OF WATER

MAINTENANCE:

- **Water Filtration**
- **Water Sanitation**
- **Chemical Balance/pH Control**

Your spa's filter system does not remove bacteria or viruses.

Water Sanitation is the responsibility of the spa owner, achieved through the regular and periodic (daily, if necessary) addition of an approved sanitizer. The sanitizer will chemically eliminate the bacteria and viruses present in the fill water or introduced during use of the spa. Bacteria and viruses can grow quickly in an undersanitized spa.

The water's chemical balance and pH control are also the responsibility of the spa owner. You'll have to add minerals to maintain proper levels of Total Alkalinity (TA), Calcium Hardness (CH) and pH. Proper water balance and pH control will minimize scale buildup, extend the life of the spa, and allow the sanitizer to work at top efficiency.

METHODS FOR TESTING THE SPA WATER

Accurate water testing and analysis is an important part of effectively managing your spa water. To follow the Hot Spot® Spa recommended program, you must have the ability to test for:

- Total Alkalinity (TA)
- Calcium Hardness (CH)
- pH
- Sanitizer

NOTE: When the FreshWater_{Ag+}™ Silver Ion Purifier with MPS is used, it is not possible to test for MPS.

Two types of testing methods are recognized and recommended by Watkins:

The Reagent Test Kit is the preferred method and provides the highest level of accuracy. The reagents come in either liquid or tablet form.

Test Strips are a convenient testing method used by many spa owners. Keep in mind that test strips are susceptible to heat and moisture contamination, which will result in inaccurate readings.

IMPORTANT: Always read and carefully follow the directions included with the Test Kit or Test Strips to ensure the accuracy of the test results.

HINTS FOR SUCCESSFUL WATER TESTING

When using the reagent test kit:

- Always take water samples 12" - 18" (30-45 cm) below the water surface.
- Rinse the test cells before and after each use.
- Do not dispose of test samples into the spa water.
- When adding drops of chemicals from the kit (the reagents) into the test block, hold the bottle vertically and add the drops slowly to be sure the correct quantity is used.
- The reagents should be replaced on a yearly basis to maintain the accuracy of the test results.

When using either a calibrated test block or test strips, test comparisons should be made in natural light.

BASIC CHEMICAL SAFETY

When using chemicals, read the labels carefully and follow directions precisely. Though chemicals protect you and your spa when used correctly, they can be hazardous in concentrated form. Always observe the following guidelines:

- Allow only a responsible person to handle spa chemicals. Keep them out of the reach of children.
- Accurately measure the exact quantities specified, never more. Do not overdose your spa.
- Handle all containers with care. Store in a cool, dry, well ventilated place.
- Always keep chemical containers closed when not in use. Replace caps on their proper containers.
- Don't inhale fumes or allow chemicals to come in contact with your eyes, nose, or mouth. Wash your hands immediately after use.
- Follow the emergency advice on the product label in case of accidental contact, or if the chemical is swallowed. Call a doctor or the local Poison Control Center. If a doctor is needed, take the product container along so that the substance can be identified.
- Don't let chemicals get on surrounding surfaces or landscaping.
- Don't use a vacuum cleaner to clean up chemical spills.
- Never smoke around chemicals. Some fumes can be highly flammable.
- Don't store any chemicals in the spa equipment compartment.

HOW TO ADD CHEMICALS TO THE WATER

IMPORTANT: All spa water chemicals, including granulated dichlor, MPS, granulated pH increaser or decreaser, granulated total alkalinity increaser, liquid stain and scale inhibitor, and liquid de-foamer must always be added directly into the filter compartment while the jet pump is running in high speed mode, and it must run for a minimum of ten minutes.

To Administer Spa Water Chemicals:

1. Fold back the cover. Carefully remove and set aside the filter compartment cover.
2. Push the JETS button to turn on the jet pump's high speed mode.
3. Carefully measure the recommended amount of chemical and slowly pour it into the filter compartment. Use care not to splash chemicals on your hands, in your eyes, on the spa shell surface or on the skirt.
4. Replace the filter compartment cover. After ten minutes, shut off the jet pump and close and lock the cover to complete the procedure. **Risk of Drowning:** Never leave an open spa unattended!

WARNING: High sanitizer levels can cause discomfort to the user's eyes, lungs and skin. Always allow the sanitizer level to fall to the recommended range before using the spa.

IMPORTANT "SUPER CHLORINATION/NON-CHLORINE SHOCK TREATMENT" NOTE: After administering a super chlorination treatment or non-chlorine shock to your spa, leave the cover open for a minimum of 20 minutes to allow the oxidizer gas to vent. A high concentration of trapped oxidizer gas which may exist as a result of the shock treatment (not daily sanitation) may eventually cause discoloration or vinyl degradation to the bottom of the cover. This type of damage is considered chemical abuse and is not covered under the terms of the limited warranty.

THE HOT SPOT® SPA WATER MAINTENANCE PROGRAM

Following the Hot Spot® Spa program will save you time and frustration as well as ensure clear, clean spa water.

IMPORTANT: Each step in your water maintenance program is dependent on the completion of the previous steps. Omitting a step or failing to reach the recommended range may cause an imbalance in your water's chemistry. Unbalanced water chemistry can damage the spa and its components as well as cause discomfort for the user.

FILLING THE SPA WITH WATER

- A. To prevent contaminants from entering the spa, Watkins recommends using the FreshStart™_{10,000} Pre-filter when filling the spa with water. Always fill the spa through the filter compartment.

WARNING: DO NOT use the FreshStart™_{10,000} Pre-filter if you plan to use granular bromine as your sanitizer (see Maintaining the Sanitizer Level section).

- B. The FreshStart™_{10,000} Pre-filter is designed to remove unwanted bacteria and contaminants such as rust, dirt, detergents, algae and chemicals from the fill water. Dissolved minerals and metals such as lead, calcium, copper and iron are not removed.
- C. Instructions are included with the FreshStart™_{10,000} Pre-filter. When the spa is filled, proceed to the next step.

BALANCING THE TOTAL ALKALINITY (TA)

- The recommended Total Alkalinity (TA) for your spa water is 125-150 ppm.
- Total Alkalinity is a measure of the total levels of carbonates, bicarbonates, hydroxides, and other alkaline substances in the water. TA is referred to as the water's "pH buffer". In other words, it's a measure of the ability of the water to resist changes in pH level.
- If the TA is too low, the pH level will fluctuate widely from high to low. Fluctuations in pH can cause corrosion or scaling of the spa components. **Low TA can be corrected by adding sodium bicarbonate.**
- If the Total Alkalinity is too high, the pH level will tend to be high and may be difficult to bring down. **It can be lowered by using sodium bisulfate.**
- Once the TA is balanced, it normally remains stable, although the addition of more water with a high or low alkalinity will raise or lower the TA reading of the water.
- When the Total Alkalinity is within the recommended range, proceed to the next step.

BALANCING THE CALCIUM HARDNESS (CH)

- The recommended Calcium Hardness (CH) level for your spa is 150-200 ppm.
- Calcium Hardness is a measure of the total amount of dissolved calcium in the water. Calcium helps control the corrosive nature of the spa's water. That's why calcium-low water (commonly known as "soft" water) is not recommended. It is very corrosive to the equipment, and can cause staining of the spa shell. **Calcium hardness increaser is the antidote.**
- If the CH is too high (commonly known as "hard water"), formation of scale on the spa's shell surface and equipment can result. **CH can be decreased by dilution—a mixture of 75% soft and 25% hard water will usually yield a reading within the correct range.** If soft water is not available or practical for you, a stain and scale control should be added to the spa water, according to instructions on its label.
- Once the CH is balanced, it normally remains stable, although the addition of more water with a high or low calcium content will raise or lower the CH reading of the water.
- When the Calcium Hardness is within the recommended range, proceed to the next step.

BALANCING THE PH

- The recommended pH level for your spa water is 7.4-7.6.
- The pH level is the measure of acidity and alkalinity. Values above 7 are alkaline; those below 7 are acidic. Maintaining the proper pH level is extremely important for:
 - Optimizing the effectiveness of the sanitizer.
 - Maintaining water that is comfortable for the user.
 - Preventing equipment deterioration.
- If the spa water's pH level is too low, the following may result:
 - The sanitizer will dissipate rapidly.
 - The water may become irritating to spa users.
 - The spa's equipment may corrode.

If the pH is too low, it can be increased by adding sodium carbonate to the spa water.

- If the pH level is too high, the following may result:
 - The sanitizer is less effective.
 - Scale will form on the spa shell surface and the equipment.
 - The water may become cloudy.
 - The filter cartridge pores may become obstructed.

If the pH is too high, it can be decreased by adding sodium bisulfate to the spa water.

NOTE: After adding sodium carbonate or sodium bisulfate, **wait two hours** before testing the water for pH. Measurements taken too soon may not be accurate.

- It is important to check the pH on a regular (weekly) basis. The pH will be affected by the bather load, the addition of new water, the addition of various chemicals, and the type of sanitizer used.
- When the pH is within the recommended range, proceed to the final step.

ALKALINE TUB WATER (SCALING ZONE)	8.2	ADD pH DECREASER TO LOWER pH
	7.8	
	7.6	
COMFORT ZONE	7.4	IDEAL
ACIDIC TUB WATER (CORROSIVE ZONE)	7.2	ADD pH INCREASER TO RAISE pH
	6.8	
	pH	

THE WATKINS WATER MAINTENANCE QUICK REFERENCE GUIDE

Steps	Ideal Range (ppm)		What Chemicals to Use	
	Minimum	Maximum	To Raise	To Lower
1 Total Alkalinity	125	150	Sodium Bicarbonate	Sodium Bisulfate
2 Calcium Hardness	150	200	Calcium Hardness Increaser	Use a mixture of 75% hard water and 25% soft water or use a Stain and Scale Inhibitor
3 pH	7.4	7.6	Sodium Carbonate	Sodium Bisulfate
4 Sanitizer	See section on Maintaining the Sanitizer Level			

MAINTAINING THE SANITIZER LEVEL

- A. Sanitizer is extremely important for killing algae, bacteria and viruses, and preventing unwanted organisms from growing in the spa. At the same time, you don't want too high a sanitizer level, or it can irritate your skin, lungs and eyes.
- B. Always maintain the sanitizer level in your spa at the recommended level for each type of sanitizer.
- C. Watkins recommends only the following sanitizers:
- FreshWater_{Ag+}TM Silver Ion Purifier with MPS
 - Sodium Dichlor (chlorine)
 - Baqua SpaTM
 - One-step granular bromine

WARNING: DO NOT use tri-chlor chlorine, any type of compressed bromine or chlorine, acid or any type of sanitizer which is not recommended by Watkins.

Refer to the following two sections to use either the FreshWater_{Ag+}TM Silver Ion Purifier or Sodium Dichlor as your sanitizer.

FRESHWATER_{Ag+}TM SILVER ION PURIFIER

The FreshWater_{Ag+}TM Silver Ion Purifier sanitizes by introducing billions of silver ions into the spa water. The silver ion sanitization process occurs in both "active" and "passive" modes.

Silver ions are also introduced into your spa water by using the FreshStartTM_{10,000} Pre-filter when filling your spa.

Passive sanitization occurs when a residual of silver ions is maintained in the spa water. In this mode, the silver ions surround but may not readily penetrate any bacteria cells that may be present in the water. During the cell reproductive process, the silver ions have the opportunity to penetrate the bacterial cell wall. Once the silver ion penetrates the cell wall, the cell is unable to reproduce. The silver ion in this state is known as a "bacteriostat." That is, although the silver ion alone does not kill the bacterium on contact, when the silver ion residual is maintained in the water, the activity of the harmful bacteria is limited to the short lifespan of one cell. In the passive mode, the water is continuously being sanitized.

Active sanitization occurs when the residual of the silver ions in the water is combined with the addition of an aggressive oxidizer such as a common non-chlorine spa shocking agent (potassium monopersulfate or potassium peroxymonosulfate, also known as MPS). While the silver ions alone cannot readily penetrate the bacterial cell walls, the oxidizing agent, when added to the water, will perforate the walls of the bacterial cells present, allowing the silver ions to enter and disable the cells. The silver ions and oxidizer working together in this state are known as a "bactericide."

Through the synergistic actions of the two elements, a rapid sanitization takes place.

IMPORTANT: Use MPS designed for use in spas only. Non-chlorine shocking agents for pools may contain a clarifier (typically a blue crystal in the shocking agent). The clarifier will react with the silver ions and cause the water to appear cloudy and will reduce the effectiveness of the silver ions. MPS with an active ingredient percentage of 30% - 33% is recommended.

SILVER ION SANITATION

It is important to follow the recommended application and maintenance programs outlined for each product's use.

To maintain a properly sanitized spa, an oxidizing agent (MPS) must be added to the spa water prior to each use.

Without the addition of the oxidizer, the "active" sanitation process is not complete and the spa bather may not be adequately protected. It is important to note that a spa being used over an extended period of time, such as a whole afternoon or evening, will need the addition of an oxidizer at least every hour or more frequently to maintain the proper active sanitation level.

In addition to the normal usage of the oxidizer, a weekly shock treatment is required. The shock treatment quickly destroys any remaining contaminants while cleaning and revitalizing the silver ion cartridge, allowing the silver ions to continue to be released into the water. Without this weekly shock treatment, the silver ion cartridge may stop releasing silver ions into the water and the spa will become undersanitized. This is the same process that should be performed when first filling or refilling your spa.

To "shock treat" the spa you may use either MPS or sodium dichlor. It will require much less sodium dichlor to administer the shock treatment than MPS (1 teaspoon of sodium dichlor has sanitizing capabilities comparable to 2 tablespoons of MPS). Sodium dichlor may be a more appropriate weekly shock for those users that experience heavy bather load conditions, or when a usual dose of MPS has been underadministered or missed entirely. If you do choose to use sodium dichlor as your weekly or start up shock treatment, you can expect the chlorine shock to reach undetectable levels within 24 hours.

IMPORTANT NOTE: As an alternative to monopersulfate (MPS), sodium dichlor may be substituted. One teaspoon of sodium dichlor equals two teaspoons of monopersulfate.

SANITATION		
When:	What to do, if using <i>Monopersulfate (MPS)</i>:	What to do, if using <i>Chlorine (Sodium Dichlor)</i>:
At spa startup or refill	Add three (3) tablespoons of monopersulfate per 250 gallons NOTE: Use the FreshStart™ _{10,000} Pre-filter when filling the spa to remove unwanted contaminants and bacteria. Hot Spot® RE & RLX 3 tablespoons Hot Spot® SE & SLX 3-1/4 tablespoons	Add one and one half (1-1/2) teaspoons of sodium dichlor per 250 gallons NOTE: Use the FreshStart™ _{10,000} Pre-filter when filling the spa to remove unwanted contaminants and bacteria. Hot Spot® RE & RLX 1-1/2 teaspoons Hot Spot® SE & SLX 1-3/4 teaspoons
Prior to each use	Add one (1) tablespoon of monopersulfate per 250 gallons Hot Spot® RE & RLX 1 tablespoon Hot Spot® SE & SLX 1-1/4 tablespoons	Add one-third (1/3) teaspoon of sodium dichlor per 250 gallons Hot Spot® RE & RLX 1/2 teaspoon Hot Spot® SE & SLX 2/3 teaspoon
Once a week	Add three (3) tablespoons of monopersulfate per 250 gallons Hot Spot® RE & RLX 3 tablespoons Hot Spot® SE & SLX 3-1/4 tablespoons	Add one and one half (1-1/2) teaspoons of sodium dichlor per 250 gallons Hot Spot® RE & RLX 1-1/2 teaspoons Hot Spot® SE & SLX 1-3/4 teaspoons
Every four months	Drain and refill your spa. Replace the FreshWater _{Ag+} ™ Silver Ion Purifier NOTE: Use the FreshStart™ _{10,000} Pre-filter when filling the spa to remove unwanted contaminants and bacteria.	Drain and refill your spa. Replace the FreshWater _{Ag+} ™ Silver Ion Purifier NOTE: Use the FreshStart™ _{10,000} Pre-filter when filling the spa to remove unwanted contaminants and bacteria.
As needed	Add three (3) tablespoons of monopersulfate per 250 gallons Hot Spot® RE & RLX 3 tablespoons Hot Spot® SE & SLX 3-1/4 tablespoons	Add one and one half (1-1/2) teaspoons of sodium dichlor per 250 gallons Hot Spot® RE & RLX 1-1/2 teaspoons Hot Spot® SE & SLX 1-3/4 teaspoons

FRESHWATER_{Ag+}TM SILVER ION PURIFIER REPLACEMENT INSTRUCTIONS

When replacing the Silver Ion Purifier (every four months), it is highly recommended that the spa be drained and refilled at the same time. After refilling the spa with water, balance the Total Alkalinity (TA), Calcium Hardness (CH) and pH to the recommended levels. Shock the spa by adding sanitizer, either MPS or sodium dichlor (See Sanitization Table for details).

1. Fold back the cover.
2. Carefully remove and set aside the filter compartment cover.
3. Remove any floating items within the filter compartment.
4. Locate the grey filter cap. Turn the filter cap counterclockwise until the cap can be removed from the filter standpipe.
5. Remove and clean filter cartridges.
6. Remove the existing FreshWater_{Ag+}TM Silver Ion Purifier.
7. Install the new FreshWater_{Ag+}TM Silver Ion Purifier into the filter standpipe. Do not force the FreshWater_{Ag+}TM Silver Ion Purifier down into the filter standpipe.
8. Reinstall the cleaned filter cartridge.
9. Replace and secure the grey filter cap.
10. Replace the filter compartment cover.
11. Fold the cover back into place.

WARNING: Never use the spa with the filter cartridge or filter standpipe removed!

SILVER IONS QUESTIONS AND ANSWERS

Question: How are the silver ions actually added to the water?

Answer: The silver ion cartridge contains ceramic beads that are infused with silver. By placing the cartridge in the filter standpipe, it is subjected to the flow of water created by the jet pump's operation. The flowing water, through a chemical erosion process, carries with it the silver ions necessary to add a sanitizing residual to the spa water.

Question: What other types of oxidizers can be used during the active sanitation process?

Answer: As an alternative to the MPS, sodium dichlor (granular chlorine) may be substituted during the active sanitation process. One teaspoon of dichlor equals two tablespoons of MPS.

Question: What happens if I do not add the weekly shock treatment?

Answer: The contaminants in the water may coat the silver ion cartridge's ceramic beads, blocking the silver ions' release into the water. When this occurs, there will be no residual of silver ions present in the water, eliminating them from the sanitizing process.

Question: How often should the FreshWater_{Ag+}TM Silver Ion Purifier cartridge be replaced?

Answer: The cartridge must be replaced every four months. Please refer to the instructions provided with each FreshWater_{Ag+}TM Silver Ion Purifier cartridge.

Question: Why can't I use bromine or biguanides instead of MPS or chlorine as my sanitizer?

Answer: Bromine and biguanides will chemically react with the sanitizing action of the silver ions. This will eliminate their beneficial sanitizing effect.

Question: I see different types of MPS in my local pool supply store. Which one should I use?

Answer: Generally, two types of non-chlorine shock (containing MPS) are available: one for swimming pools and one for spas. Use only non-chlorine shock designed for use in spas. Non-chlorine shock for pools may contain a clarifier (typically blue crystals in the shocking agent). The clarifier will react with the silver ions and cause the water to appear cloudy and reduce the effectiveness of the silver ions. Only MPS (buffered for pH) designed for use in spas with an active ingredient percentage of 30-33% is recommended.

DOS AND DON'TS

- DO add MPS (or other approved sanitizing activator) prior to each use.
- DO shock the spa weekly with sanitizer (use either MPS or sodium dichlor).
- DO change the FreshWater_{Ag+}TM Silver Ion Purifier every 4 months.
- DO test Total Alkalinity and pH weekly.
- DO use MPS for spas only.

- DO store the MPS in a tightly sealed container in a cool, dry place.
- DON'T use bromine, sodium bromide or biguanides. These are an active sanitizer and will combine with the silver ions to inactivate them.
- DON'T use a water clarifier. Clarifiers will cause the spa water to become cloudy.

CHLORINE (SODIUM DICHLOR)

- A. Sanitizing chemicals, such as chlorine, are oxidants that kill bacteria and viruses in the water. The Free Chlorine Residual (FCR) is a measure of the amount of unused chlorine available to sanitize the spa. The recommended FCR for your spa water is 3.0-5.0 ppm.
- B. Watkins Manufacturing Corporation recommends the use of Sodium Dichlor type granulated chlorine for sanitizing the water. Sodium Dichlor is preferred because it is totally soluble, dissolves quickly and is nearly pH neutral.
- C. Maintaining the proper level of chlorine during use is extremely important.
- D. If the FCR is too low, bacteria and viruses can grow rapidly in the warm water. **Increase the FCR by adding granulated Sodium Dichlor.**
- E. If the FCR is too high, the water can cause discomfort to the user's eyes, lungs and skin. **Simply allow some time to pass. The FCR level will naturally drop over time.**
- F. When the Free Chlorine Residual is within the recommended range, the spa is ready to be enjoyed.

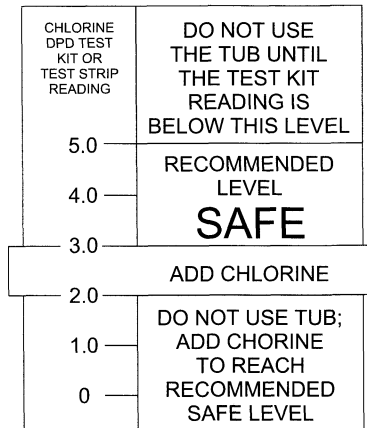

WARNING: There are several forms of stabilized chlorine available for use in spas and swimming pools and each form has specific chemical characteristics. It is extremely important that the one you choose is specifically designed for use in spas. Use of an incorrect product such as tri-chlor, which has a very low pH (2.6), dissolves too quickly in hot water resulting in extremely high levels of chlorine, and is designed for concrete or plaster swimming pools, WILL cause damage to your spa. Use of a liquid or concentrated form of sanitizer WILL damage your spa and is specifically not covered under the terms of the limited warranty.

IMPORTANT: Granulated chlorine (Sodium Dichlor) will degrade if stored improperly. We recommend purchasing chlorine in one or two pound containers and storing it in a cool, dry place to maintain its potency.

SUPER CHLORINATION

Super Chlorination is designed to "burn-off" the build-up of chloramines (used chlorine), to eliminate the chlorine smell and to allow the proper level of free chlorine to be maintained.

When giving your water a super chlorination treatment, open the cover at least half way for twenty minutes to allow the chlorine gas to vent off. The high concentration of chlorine gas which may exist as a result of super chlorination (not daily sanitation) may eventually cause discoloration or degradation to the bottom of the cover or the tile grouting, which would not be covered under the terms of your warranty.

IMPORTANT: Always allow the Free Chlorine Residual to fall to 5ppm before using the spa.

WARNING: Never leave an open spa unattended, especially if there are children present!

BUILDING A SANITIZER ROUTINE

During the first month of ownership, measure the sanitizer residual daily in order to establish standards for User Load and Usage Time versus Sanitizer Needed.

- The User Load of the spa is the number of times anyone enters the spa.
- The Usage Time is simply the amount of time a user spends in the spa.
- Sanitizer Needed is the amount of Free Chlorine Residual needed to accommodate the number of users and their combined usage time.

For example, two spa users who regularly use the spa once an evening for twenty minutes create a specific and somewhat consistent demand on the sanitizer. During the first month of ownership, these two users can determine exactly how much sanitizer to use in order to maintain the proper residual. If, at any time, the user load and/or usage pattern changes dramatically (invited guests), the amount and frequency of sanitizer required increases dramatically.

The greater the usage time or the bather load, the faster the residual value is diminished.

CHLORINE MAINTENANCE SCHEDULE

Recommended Chlorine	Sodium dichloro-s-triazinetrione, granular or Sodium dichloro-isocyanurate, granular (common name: Dichlor Chlorine, granular, 53%-65% available chlorine)
Daily Maintenance	Maintain a level of 3-5 ppm free available chlorine residual when spa is in use. Add the recommended amount of dichlor into the filter compartment while the jet pump is operating. Run the jet pump for 10 minutes.
Weekly Maintenance	Super chlorinate (shock treatment): Add the recommended amount of dichlor (open cover) into the filter compartment while the jet pump is operating to raise the free available chlorine residual above 10 ppm. Run the jet pump for 10 minutes. Allow the free chlorine residual to drop to 5 ppm before using the spa!
Important	<ul style="list-style-type: none"> • A spa being used over an extended period of time, such as a whole afternoon or evening, will need chlorine added at least every hour or more frequently to maintain the average level of 3-5 ppm free chlorine residual. • The use of trichloro-s-triazinetrione (tri-chlor) for water sanitation, or swimming pool acid (muriatic acid) to lower the pH could damage your spa and is not recommended. • Keeping the spa cover on and secured at all times (except when the spa is in use) will reduce the chemical demand and help to maintain the spa's energy efficiency. • Always add all spa chemical into the filter compartment while the jet pump is operating. • Always test the spa water temperature with your hand to make sure it is comfortable before entering.
Warning	Improper water chemistry or the use of non-recommended chemicals may cause severe damage to the spa surface or equipment which is not covered by the spa warranty!

SUPPLEMENTAL WATER MAINTENANCE

Proper water sanitation and mineral balance (pH control) are absolutely essential for a complete spa water maintenance program. Here are three other popular water additives that are optional:

Flocculating Agent

The flocculant clarifies the water by removing particles too small for some cartridge filters to catch. The flocculating agent consists of relatively large particles, which when added to water, attract smaller particles to them like magnets. The small particles attach to the flocculating agent's large particles to form a combination which is large enough to be trapped in the filter. It is important to remember that the use of flocculating agents does not improve water sanitization. With proper sanitation, the small particles are rendered inert (biologically dead).

Foam Inhibitors

Spa water requires changing due to the buildup of soap in the water. Typically, soap will cause the spa water to foam when the jets are used. Soap is introduced into the spa water from two sources: users' bodies, which retain a soap residual after showering, and swimming apparel, which retains soap after washing.

Foam inhibitors can suppress foam, but cannot remove soap from the water. Soap is very difficult to remove from the water because soap is not oxidized by any chemical added to the spa. Only ozone can oxidize soap.

Eventually the soap build-up in the water will be concentrated, resulting in an unclean feeling on the bather's skin which is impossible to remedy. When this occurs, it's time to drain and refill the spa. Depending on the soap input, the water should last about 4 months before needing to be drained.

Mineral Deposit Inhibitors

As water evaporates from your spa and new water is added, the amount of dissolved minerals will increase. (Minimize evaporation by keeping the cover on the spa whenever possible.) The spa water may eventually become "hard" (Calcium Hardness too high) enough to damage the heater by calcifying its surface. Proper pH control can minimize this.

Normal soap build-up will require water replacement regularly enough that mineral deposits normally are not a problem.

Occasionally, high iron or copper content in the water may produce green or brown stains on the spa. A mineral deposit inhibitor may help to reduce these metals.

NOTE: Well water may contain high concentrations of minerals. The use of a low water volume, extra-fine pore water filter (in-line pre-filter such as the FreshStart™ 10,000 Pre-filter) will help to remove many of the larger particles during the filling of the spa. In-line pre-filters can be purchased at your local Hot Spot® Spa dealer.

DOS AND DON'TS

- DON'T use swimming pool (muriatic) acid to lower pH.
- DON'T splash pH increaser additives on the skirt.
- DON'T use Compressed Sanitizers.

Bromine is an effective sanitizer; however, the methods by which it is administered to the spa water and the quality of the bromine product varies greatly among manufacturers.

The use of bromine sticks or tablets in floaters, which may become entrapped in a lounge or cooling seat (or sink to the spa floor), have been shown to cause discoloration of or surface distress to a spa's shell.

- DON'T use a floater type sanitization system as a low or no maintenance solution to your spa maintenance program.

The spa shell easily can withstand the effects of a properly administered sanitizer. Floating dispensers can become trapped in one area and cause an over-sanitization (or chemical burn) of that particular area.

If the dispenser setting is too high, the high concentration can discolor the spa shell and damage the underside of the cover.

Automatic floating dispensers have a tendency to either over-brominate or under-brominate as the rate of erosion varies greatly. Damage to the spa and cover can occur very quickly.

WARNING: Watkins Manufacturing Corporation DOES NOT recommend the use of any floating chemical dispenser. Damage to the spa shell or components caused by a floating chemical dispenser is specifically not covered under the terms of the limited warranty.

- DON'T use a sanitizer which is not designed for spas.
- DON'T use Household Bleach (liquid sodium hypochlorite).
- DON'T broadcast or sprinkle the chemicals onto the water surface. This method may cause chemically-induced spa surface blistering (chemical abuse).
- DO add all chemicals slowly into the filter compartment with the jet pump operating on high speed for ten minutes.
- DO use special care if using baking soda to clean either the interior or exterior plastic surfaces.
- DO use only a granular form of sanitizer (chlorine or MPS).

COMMON WATER CHEMISTRY QUESTIONS

Question: Why can't I use a floater to sanitize my spa water?

Answer: Watkins does not recommend the use of a floater for three reasons.

1. The floater is unable to control the rate at which sanitizer is dissolved into the water. When a floater is first placed in a spa, the sanitizer level can be extremely high. High sanitizer levels can chemically burn or discolor the spa's shell or the underside of the cover. Then, after a period of time, the sanitizer level dispensed by the floater will fall to near zero. A low sanitizer level will allow viruses, bacteria or algae to grow.
2. Floaters tend to stay in one area of the spa most of the time (usually over the cool down seat), causing this area to be exposed to extreme sanitizer levels.
3. The floater may allow pieces of the highly concentrated sanitizer to fall out and settle on the floor or seat of the spa shell. These pieces of sanitizer will chemically burn (blister) the spa shell. Although your spa shell is specifically designed to resist the effects of spa chemicals, no spa surface can withstand this type of highly concentrated chemical. Remember, chemical abuse is specifically not covered under the terms of the warranty.

Question: When I open my spa, I smell chlorine. How do I get rid of this smell?

Answer: There are two types of chlorine in your spa. The first is the Free Chlorine Residual, which is the chlorine available to sanitize your spa. This available free chlorine does not have an odor. The second is Chloramine, which is residue from chlorine already expended. Chloramines have a strong chlorine odor. The smell from Chloramines can be eliminated by "shocking" the water. If you smell chlorine in the water, your spa is reminding you to add a shock treatment.

Question: Why can't I fill my spa with soft water?

Answer: Soft water is essentially the same as regular water except that most or all of the calcium has been replaced by sodium. Soft water may be corrosive to the heater and other components. Replacement of spa components damaged by soft water is extremely expensive.

Question: I am trying to reduce the number of chemicals to which my family is exposed. Do I really need to use so many chemicals and in such large amounts?

Answer: While over-exposure to any chemical can be unhealthy, many low levels of chemicals are effective and beneficial. In the case of spa water, the chemicals recommended in the Hot Spot® Spa Water Maintenance program are needed to protect the user from water-borne pathogens (disease-causing microbes) and to prevent corrosion of spa components.

Question: Why isn't water chemistry damage covered by the warranty?

Answer: The chemical levels and water quality of the water in the spa are under your direct control. With proper basic care, the spa will provide many years of hot water relaxation. If you are unsure about any chemical or its usage in the spa, contact your Authorized Dealer or Watkins Manufacturing.

WATER TERMINOLOGY

The following chemical terms are used in this Water Quality and Maintenance section. Understanding their meaning will help you to better understand the water maintenance process.

Bromamines: Compounds formed when bromine combines with nitrogen from body oils, urine, perspiration, etc. Unlike chloramines, bromamines have no pungent odor and are effective sanitizers.

Bromine: A halogen sanitizer (in the same chemical family as chlorine). Bromine is commonly used in stick, tablet, or granular form. See the DO's and DON'Ts of Spa Water Maintenance for additional information.

Calcium Hardness: The amount of dissolved calcium in the spa water. This should be approximately 150-200 ppm. High levels of calcium can cause cloudy water and scaling. Low levels can cause harm to the spa equipment.

Chloramines: Compounds formed when chlorine combines with nitrogen from body oils, urine, perspiration, etc. Chloramines can cause eye irritation as well as having a strong odor. Unlike bromamines, chloramines are weaker, slower sanitizers.

Chlorine: An efficient sanitizing chemical for spas. Watkins Manufacturing Corporation recommends the use of Sodium Dichlor-type granulated chlorine. This type is preferred because it is totally soluble and nearly pH neutral.

Chlorine (or Bromine) Residual: The amount of chlorine or bromine remaining after chlorine or bromine demand has been satisfied. The residual is, therefore, the amount of sanitizer which is chemically available to kill bacteria, viruses and algae.

Corrosion: The gradual wearing away of metal spa parts, usually caused by chemical action. Generally, corrosion is caused by low pH or by water with levels of TA, CH, pH or sanitizer which are outside the recommended ranges.

DPD: The preferred reagent used in test kits to measure the Free Available Chlorine.

Halogen: Any one of these five elements: fluorine, chlorine, bromine, iodine and astatine.

MPS: Monopersulfate is the non-chlorine oxidizer used with the FreshWater_{Ag+}™ Silver Ion Purification system.

Pathogen: A microorganism such as bacterium that cause disease.

pH: The measure of the spa water's acidity and alkalinity. The recommended pH for the spa water is 7.4 to 7.6. Below 7.0 (considered neutral), the spa water is too acidic and can damage the heating system. Above 7.8, the water is too alkaline and can result in cloudy water and scale formation on the shell and heater.

ppm: The abbreviation of "parts per million", the standard measurement of chemical concentration in water. Identical to mg/l (milligrams per liter).

Reagent: A chemical material in liquid, powder or tablet form for use in chemical testing.

Scale: Rough calcium-bearing deposits that can coat spa surfaces, heaters, plumbing lines and clog filters. Generally, scaling is caused by mineral content combined with high pH. Additionally, scale forms more readily at higher water temperatures.

Shock Treatment: Also known as "super-chlorination" when chlorine is used. Shock treatment is a process of adding significant doses of a quick dissolving sanitizer (MPS or sodium dichlor is recommended) to oxidize non-filterable organic waste and to remove chloramines and bromamines.

Total Alkalinity: The amount of bicarbonates, carbonates, and hydroxides present in spa water. Proper total alkalinity is important for pH control. If the TA is too high, the pH is difficult to adjust. If the TA is too low, the pH will be difficult to hold at the proper level. The desired range of TA in spa water is 125 to 150 ppm.

TROUBLESHOOTING

Watkins Manufacturing Corporation strives to provide the most trouble-free spas on the market. Should you experience any problem whatsoever, do not hesitate to contact your authorized Hot Spot® Spa dealer. Here are some tips to help you to diagnose and rectify some more common sources of trouble yourself, if you choose to do so.

GENERAL OPERATION TROUBLESHOOTING GUIDE		
Problem	Probable causes	Solutions
Entire spa is inoperative	<ul style="list-style-type: none"> • Power failure / not plugged in • GFCI tripped / Spa circuit breaker tripped • Heater high limit thermostat tripped 	<ul style="list-style-type: none"> • Check power source • Reset GFCI; call for service if it will not reset / Reset spa circuit breaker • Disconnect power for at least thirty seconds to reset heater high limit. If it will not reset, check for clogged filter. If tripping continues, call for service.
Spa does not heat; jets and light operate (Ready indicator is dark)	<ul style="list-style-type: none"> • Heater thermal cut-off tripped 	<ul style="list-style-type: none"> • Reset heater thermal cut-off and check for clogged filter. Heater thermal cut-off will reset when the flow of water through the heater has been restored. Call for service if it heater thermal cut-off trips frequently.
Jets weak or surging	<ul style="list-style-type: none"> • Spa water level too low • Filters clogged / Jet intake screens clogged • Jet nozzles closed / Air valve closed 	<ul style="list-style-type: none"> • Add water • Clean filters / Clean jet intake screens • Open jet nozzles / Open air valve
Light inoperative	<ul style="list-style-type: none"> • Bulb burned out 	<ul style="list-style-type: none"> • Replace bulb
Pump operates constantly	<ul style="list-style-type: none"> • Air switch tubing is disconnected, contains water, or has become kinked or damaged 	<ul style="list-style-type: none"> • Connect the tubing if disconnected; if it contains water, evacuate it and replace the air switch button; if it is kinked or damaged, replace it
Power indicator blinking (Entire spa inoperative)	<ul style="list-style-type: none"> • Heater high limit thermostat tripped 	<ul style="list-style-type: none"> • Reset heater high limit by pressing the red button on the electronic control box (in the equipment compartment). If tripping continues, clean the filter, then if tripping still occurs, call for service.
Ready indicator blinking	<ul style="list-style-type: none"> • Temperature sensor problem 	<ul style="list-style-type: none"> • Disconnect power for at least thirty seconds. If blinking continues, call for service.

SPA WATER MAINTENANCE TROUBLESHOOTING GUIDE		
Problem	Probable causes	Solutions
Cloudy Water	<ul style="list-style-type: none"> • Dirty filters • Excessive oils / organic matter • Improper sanitization • Suspended particles / organic matter • Overused or old water 	<ul style="list-style-type: none"> • Clean filters • Shock spa with sanitizer • Add sanitizer • Adjust pH and/or alkalinity to recommended range • Run jet pump(s) and clean filters • Drain and refill the spa
Water Odor	<ul style="list-style-type: none"> • Excessive organics in water • Improper sanitization • Low pH 	<ul style="list-style-type: none"> • Shock spa with sanitizer • Add sanitizer • Adjust pH to recommended range
Chlorine Odor	<ul style="list-style-type: none"> • Chloramine level too high • Low pH 	<ul style="list-style-type: none"> • Shock spa with sanitizer • Adjust pH to recommended range
Musty Odor	<ul style="list-style-type: none"> • Bacteria or algae growth 	<ul style="list-style-type: none"> • Shock spa with sanitizer—if problem is visible or persistent, drain, clean and refill the spa
Organic buildup / scum ring around spa	<ul style="list-style-type: none"> • Buildup of oils and dirt 	<ul style="list-style-type: none"> • Wipe off scum with clean rag—if severe, drain the spa, use a spa surface and tile cleaner to remove the scum and refill the spa
Algae Growth	<ul style="list-style-type: none"> • High pH • Low sanitizer level 	<ul style="list-style-type: none"> • Shock spa with sanitizer and adjust pH • Shock spa with sanitizer and maintain sanitizer level
Eye Irritation	<ul style="list-style-type: none"> • Low pH • Low sanitizer level 	<ul style="list-style-type: none"> • Adjust pH • Shock spa with sanitizer and maintain sanitizer level
Skin Irritation / Rash	<ul style="list-style-type: none"> • Unsanitary water • Free chlorine level above 5 ppm 	<ul style="list-style-type: none"> • Shock spa with sanitizer and maintain sanitizer level • Allow free chlorine level to drop below 5 ppm before spa use
Stains	<ul style="list-style-type: none"> • Total alkalinity and/or pH too low • High iron or copper in source water 	<ul style="list-style-type: none"> • Adjust total alkalinity and/or pH • Use a metal deposit inhibitor
Scale	<ul style="list-style-type: none"> • High calcium content in water—total alkalinity and pH too high 	<ul style="list-style-type: none"> • Adjust total alkalinity and pH—if scale requires removal, drain the spa, scrub off the scale, refill the spa and balance the water

VI. SERVICE INFORMATION

GENERAL INFORMATION

Your Hot Spot® Spa has been designed to provide years of trouble-free use. As with any appliance, problems may occasionally occur that require the expertise of a qualified service person. Though such simple repairs as resetting a GFCI switch or breaker, resetting a high limit thermostat or replacing a light bulb may not require a service call, they may indicate that a more serious condition exists. These conditions may require an experienced service person. Before calling for service, please refer to the Troubleshooting Guide.

NOTE: Always retain your original sales receipt for future reference.

GFCI AND HIGH LIMIT THERMOSTAT

If your spa fails to operate at any time, the following items should be checked:

1. Check the power supply to the spa.
2. Check the GFCI (located on the control panel in standard models or the electrical subpanel in 30 amp converted models) and see if it has tripped. If a GFCI has tripped, reset it. If it will not reset, this may be an indication of a ground fault (short circuit) within the electrical components. Contact an authorized service technician for a complete diagnosis.
3. If, upon checking the GFCI you find it has not tripped, check the house breaker panel and ensure the main breaker for the electrical circuit supplying the spa has not tripped. If it has, this is an indication that either the circuit was overloaded or a ground fault exists between the breaker panel and the spa receptacle. Contact a qualified electrician.
4. If, upon checking the main house breaker, you find no failures, the heater high-limit thermostat should be checked. Tripping of the heater high-limit thermostat is normally a result of one or a combination of any of these problems:
1) blockage within the system plumbing, 2) switch malfunction in the heater circuit, or 3) the low speed mode of the jet pump is not functioning.
5. To check the heater high limit, open the equipment access panel and depress the red button labeled heater reset. If it has tripped you will hear a click when the switch resets. Push the JETS button to check the spa's operation. (The power on indicator will also be blinking of the heater high-limit switch has tripped.)
6. If, upon checking the heater high-limit thermostat, you find it has not tripped, the "mini" circuit breaker should be checked. The circuit breaker is located on the front of the control panel. Carefully push the button to reset the breaker. If the breaker continues to trip, contact an Authorized Service Technician for a complete diagnosis.

If the spa does not function and the GFCI and heater high-limit thermostat or the circuit breaker have not tripped, then the problem should be referred to a qualified service technician. Refer to the Troubleshooting Guide for additional service information.

MISCELLANEOUS SERVICE INFORMATION

The high-limit thermostat capillary is not an electrical wire. It is a copper spae with a tiny bore which carries an expansive fluid. NEVER cut, bend or kink the tube.

The jet pump is equipped with an overload cut-off switch, which is designed to protect the pump from overheating. If the pump shuts itself off in a new spa, it is usually the result of one, or a combination of, the following factors:

High Temperature: During the summer months, especially in warmer climates, the ambient temperature contributes to excessively high temperatures within the equipment compartment.

Friction: Sometimes the moving parts of a new pump are tight enough to cause heat build-up due to friction. After a normal break-in period, the pump will run cooler.

Improper House Wiring: If the spa is not connected to a dedicated circuit, or is connected to an extension cord, or the house wiring is undersized, the pump may starve for voltage and therefore may draw more amperage and generate excessive heat. This will often cause the circuit breaker to trip repeatedly.

IMPORTANT:

1. If the pump is shutting down due to excessive heat, make sure the equipment compartment has adequate ventilation. The air gap at the bottom and the jet pump vent at the bottom left corner must not be blocked. Should your jet pump continue to shut off after short periods of use, contact a qualified service technician.
2. The Hot Spot® Spa is equipped with a safety suction spring valve which will break the prime of the jet pump if both suction fittings are obstructed.

ACTS INVALIDATING WARRANTY

The limited warranty is void if the Hot Spot® Spa has been subjected to alteration, misuse or abuse, or if any repairs on the spa are attempted by anyone other than an authorized representative of Watkins Manufacturing Corporation. Alteration is defined as any component or plumbing change, electrical conversion, or the addition of any non-approved sanitation or water purification device or heating system which contributes to a component failure, unit failure or unsafe operating condition. Misuse and abuse shall include any operation of the spa other than in accordance with Watkins Manufacturing Corporation printed instructions, or use of the spa in an application for which it is not designed; specifically: use of the spa in a non-residential application; damage caused by operation of the spa at water temperatures outside the range of 32°F and 120 °F; damage caused by a dirty, clogged or calcified filter cartridge; damage to the spa surface caused by the use of Tri-Chloro chlorine, chemical tablets, acid, or any other spa sanitizing chemicals or spa surface cleaners which are not recommended by Watkins Manufacturing Corporation; damage caused by allowing undissolved spa sanitizing chemicals to lie on the spa surface (no spa surface material can withstand this kind of abuse); damage to components or spa surface caused by improper pH balance or other improper water chemistry maintenance; and damage to the spa surface caused by leaving the spa uncovered while empty of water and in direct exposure to sunlight (this may cause solar heating distress in warm weather regions). These are considered abuses and may invalidate this warranty.

DISCLAIMERS

Watkins Manufacturing Corporation shall not be liable for loss of use of the Hot Spot® Spa or other incidental or consequential costs, expenses or damages, which may include but are not limited to, the removal of a permanent deck or other custom fixture. Any implied warranty shall have a duration equal to the duration of the applicable warranty stated above. Under no circumstances shall Watkins Manufacturing Corporation or any of its representatives be held liable for injury to any person or damage to any property, however arising.

WATKINS CUSTOMER SERVICE

If you have any questions about any aspect of your Hot Spot® Spa set-up, operation or maintenance that have not been answered by this manual, consult your Hot Spot® Spa dealer.

Watkins Manufacturing Corporation can be reached at: 800-999-4688 (Extension 432), Monday through Friday, 8 a.m. to 5 p.m. Pacific Standard Time (PST).

WatkinsTM

The Home Relaxation Specialists

WATKINS MANUFACTURING CORPORATION
VISTA, CALIFORNIA
USA



This manual contains installation, operating, maintenance and service information for the following Hot Spot[®] Spa models:

<u>USA MODELS</u>	<u>EFFECTIVE DATE</u>	<u>CANADIAN MODELS</u>	<u>EFFECTIVE DATE</u>
HOT SPOT RE, RLX (Model Z)	1/98	HOT SPOT RE, RLX (Model ZC)	1/98
HOT SPOT SE, SLX (Model Y)	1/98	HOT SPOT SE, SLX (Model YC)	1/98

©1998 Watkins Manufacturing Corporation. Hot Spot, Endurol, No-Fault, Wavemaster, FreshStart, FreshWater_{Ag+}, The anywhere anytime tub, and The home relaxation specialists are trademarks of Watkins Manufacturing Corporation. Baqua Spa is a trademark of ZENECA, Inc.

PART # 61118, REV. A (1/98)