

The Cirrus™ IG

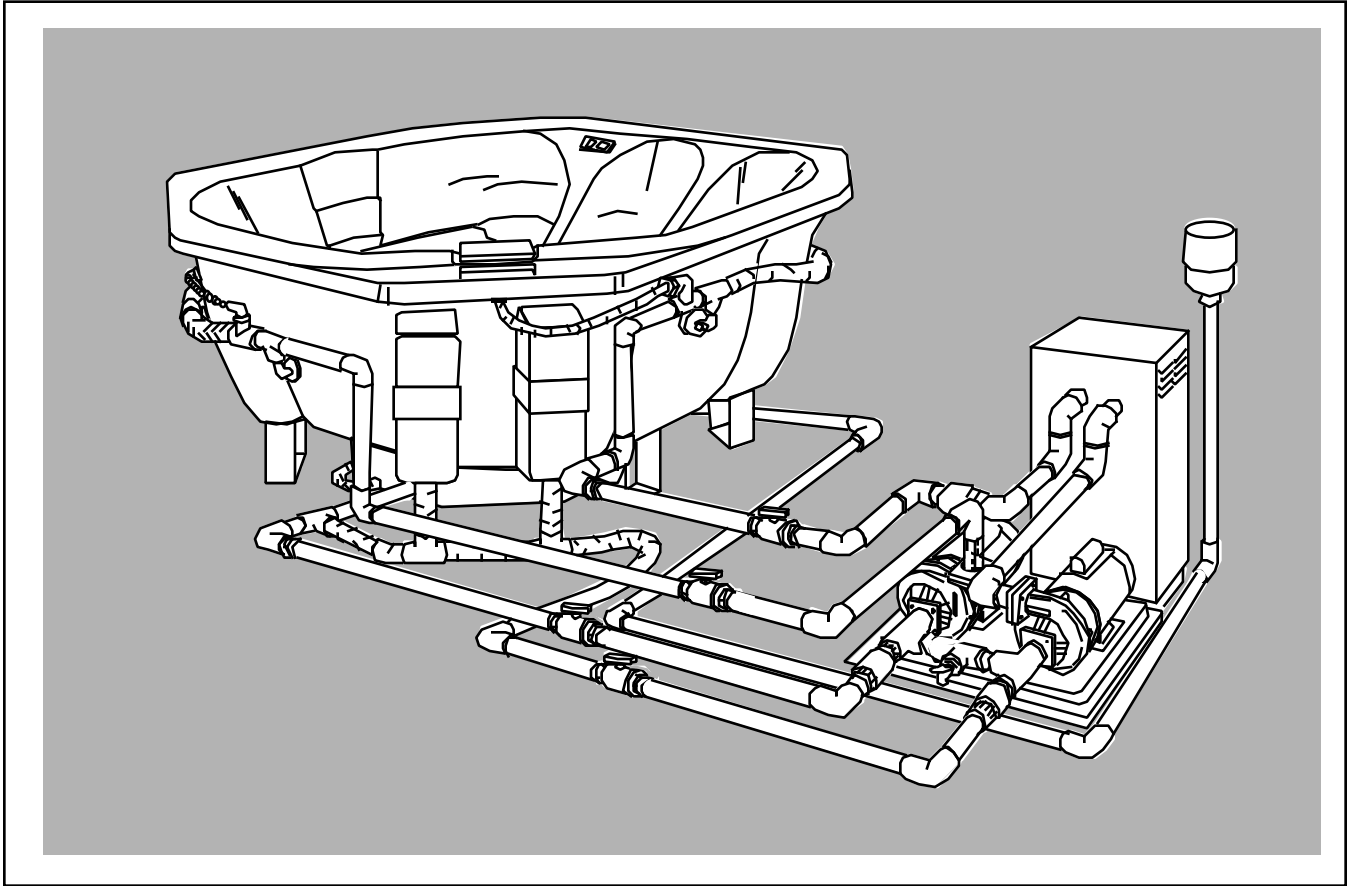

Owner's Manual



IMPORTANT SAFETY INFORMATION

READ AND FOLLOW ALL INSTALLATION INSTRUCTIONS

Jacuzzi Whirlpool Bath does not recommend spa water temperatures in excess of 104°F. High water temperatures in excess of 104°F and/or prolonged periods of use can raise the internal human body temperature excessively and impair the body's ability to regulate its internal temperature. Limit your initial use of the spa to 10-15 minutes. High body temperatures affect people differently; consult your physician about your safety and comfort before using the spa.

The elderly, the infirm, and children should not use the spa unattended. Infants should not be permitted in the spa at water temperatures over 100°F. Pregnant women and people with heart conditions should consult their physicians before using the spa at water temperatures over 100°F.

Extra care should be taken when using the spa and consuming alcoholic beverages. Alcohol, drugs, or certain medications such as tranquilizers affect a person's ability to withstand high temperatures and may produce dangerous effects.

Keep body, hair, and clothing a minimum of 12 inches away from suction fitting and skimmers at all times when the spa is operating. Hair longer than shoulder length should be secured close to the head, or a bathing cap should be worn. Do not remove the suction grilles! They are safety devices and must always be in place on the suction fitting to minimize the potential hazard of hair entanglement or body entrapment.

The wet surface of the spa is slippery. Use care when entering and exiting.

While the optional spa cover is rigid, it is not designed to support any weight. Therefore, as a safety precaution, do not sit, stand or lie on it.

The spa must be installed with adequate electrical service access and water drainage system. (See Installation Instructions.)

When using the electrical equipment, basic safety precautions should always be followed:

Do not use electrically connected devices such as television, radio, or stereo speakers, lights, cooking devices, or telephones within 5 feet of the spa while the spa is being used. Lighting fixtures must not be located directly above or within 5 feet of the spa. If located within 10 feet of the spa, they must be on a circuit protected by a GFCI.

Do not apply power to the spa unless it is filled with water to the normal water level, which is to the water level indicator mark on the skimmer frame. Activating the spa when there is an insufficient amount of water can damage the circulation pump and may cause a fire.

Read manufacturer's safety information provided with all optional equipment.

Save These Instructions for Future Use.

Owner's Record

Date Purchased _____

Purchased From _____

Installed By _____

Spa Serial Number _____ Model # D500000

(See page 2 for location of serial number.)

The Cirrus IG™ Whirlpool Spa

Owner's Manual

Model D500000

Contents

	Page
Installation Instructions _____	3-14
Inspection and Shipping Claim _____	3
Unpacking _____	3
Indoor Installation, _____	4
Outdoor installation, Below Ground _____	5
Outdoor installation, Below Ground (cont). _____	6
Outdoor Installation, Ground level or Above _____	7
Equipment Pack Site Preparation _____	8
Electrical Service _____	9
Plumbing _____	10
Heater and Air Channel Plumbing _____	11
Optional Air Blower _____	12
Seat Air Holes _____	13
Spa Set-up, Alternative use for Water Rainbow™ _____	14
Operation Instructions _____	15-19
Equipment Set-up _____	15
Priming Procedure I _____	16
Priming Procedure II _____	17
Spa Controls, Normal Operation _____	18
Spa _____	19
Silent Air Induction _____	19
Water Rainbow™ Spout _____	19
Maintenance _____	20-24
Water Quality and Water Chemistry _____	20
Filtration _____	20
Water Chemistry _____	20,21
Disinfecting _____	21
Balancing pH _____	21
Balancing Total Alkalinity _____	21
Water Quality Definitions _____	21
Water Level/Drain _____	22
Skimmer Basket Maintenance _____	22
Filter Maintenance _____	22
Automatic Filtration/Maintenance _____	23
Winterizing _____	23
Cleaning Your Spa _____	24
Covering Your Spa _____	24
Repairs to the Acrylic _____	24
Troubleshooting Guide _____	25-26

The Cirrus IG Whirlpool Spa Specifications

STANDARD FEATURES

- Three directionally-adjustable jets
- Six high volume fully-adjustable jets
- Water Rainbow Fill Spout recirculating spout
- Two patented front load skimmer/filters
- Safety suction design
- Integrated steps
- Continuous contoured seating
- Separate equipment pack with:
2.0 hp whirlpool motor-pump and
0.75 hp heater/filter motor-pump

OPTIONS

- Air Blower
- Gas Heater
- Electric Heater
- Rigid Insulated Spa Cover
- Air Switch/Timer
- Spa Pillows

EQUIPMENT PACK

SUCTION EQUALIZER TUBE ASSEMBLY
(TO BE INSTALLED ON SITE)

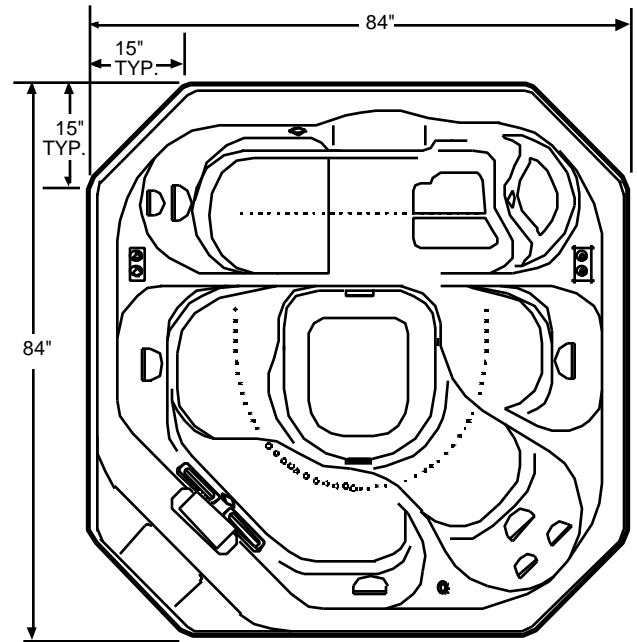
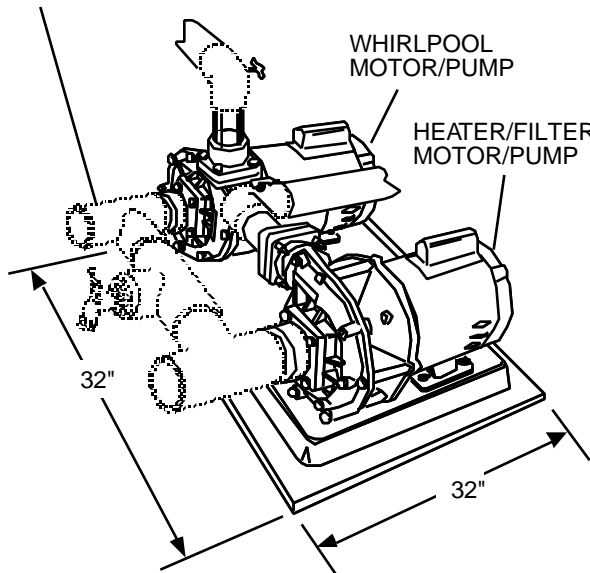

AIR CHANNEL HOLES TO BE DRILLED ON SITE. (OPTIONAL)

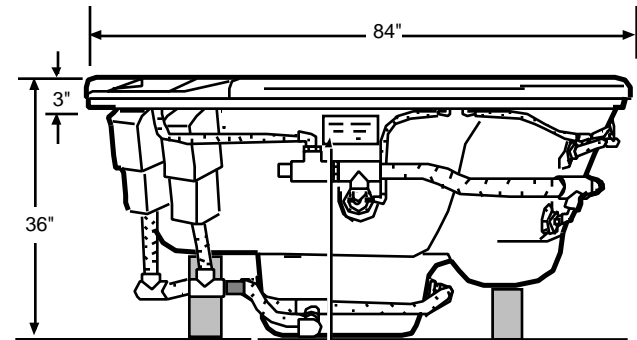

SERIAL NUMBER LOCATION

BLACK RECTANGLES IN ILLUSTRATION SHOW PLACE-
MENT OF WOOD SUPPORTS. SEE PAGE 4 OF
INSTALLATION INSTRUCTIONS.

LOCATE WOODEN SUPPORTS BENEATH OUTER
PERIMETER OF SEATING AREA.

SPECIFICATIONS

MODEL	DIMENSIONS	WHIRLPOOL MOTOR/PUMP	HEATER/FILTER MOTOR/PUMP	PRODUCT WEIGHT	OPERATING GALLONAGE	SHIPPING WEIGHT	ELECTRICAL REQUIREMENTS
Cirrus IG (C500000)	84" (2134 mm) L. 84" (2134 mm) W. 36" (914 mm) H.	—	—	321 lbs. (145.6 kg.)	375 U.S. gal. (1419 ltrs.)	615 lbs.* (280kg)	—
Equipment Pack	32" (81 mm) L. 20" (51 mm) W. 31" (79 mm) H.	2.0 HP 230 VAC 10.0 AMPS 3450 RPM Single Phase 60 Hz	0.75 HP 230 VAC 4.9 AMP 3450 RPM Single Phase 60 Hz	—	—	—	Two 230 VAC/15 AMP Circuits

* Shipping weight includes equipment pack weight.

PRODUCT SPECIFICATIONS ARE SUBJECT TO CHANGE WITHOUT NOTICE.

INSTALLATION

Inspection and Shipping Claims

Check for shipping damage upon receipt of the spa. Jacuzzi Whirlpool Bath is not responsible for damage to the spa sustained during shipping. If damage is evident before unpacking, see instructions regarding shipping claims on the outside of the carton and immediately file a claim with the carrier.

Once the spa has been removed from the carton and before it is permanently installed (see below on this page for unpacking instructions), check the spa completely for damage. Fill the shell with water and operate the system (see Operating Instructions) to check for leaks which have resulted from shipping or handling. All Jacuzzi Whirlpool Bath spas are factory tested for proper operation and water tight connections prior to shipping. If leaks or other problems are detected, immediately notify your Jacuzzi Whirlpool Bath dealer or Authorized Service Agent, or call Jacuzzi Whirlpool Bath, (510) 938-7070 or (510) 938-7411 for Warranty Service.

Note: Damage or defects which could have been discovered and repaired prior to installation and which are claimed after final installation of the spa, are excluded from our warranty.

Unpacking

1. Remove the outer carton by disassembling bracing and side panels.
2. Remove the equipment pack from the pallet by removing bolts and nuts securing the equipment pack base to the pallet.
3. The spa should be moved to its final location on a dolly in its upright position while still attached to its shipping pallet.
4. When the spa has been moved to its final location, preferably a concrete pad or other supported surfaces, place a 4 x 4 x 72" wooden block beside the base side (bottom end) of the spa so it is parallel with the pallet.
5. Tip the spa over onto its bottom with the block supporting the spa. **Do not handle the spa by its plumbing; handle it by the shell only.**
6. Detach the spa from the shipping pallet by removing the bolts from the pallet.
7. Leave the remaining plastic sheet attached to the spa shell to keep the shell clean and free from debris during installation.
8. Before installation begins, remove and retain the owner's packet from the product accessory box. This packet contains the Specifications and Installation Instructions, and Operating Instructions. The accessory box also contains filter cartridges, skimmer baskets, check valves, and the equalizer tube assembly with installation hardware and connections to be installed on the equipment pack. Set aside the filter cartridges in a dry place until it is time to set up the spa equipment. Read all instructions contained in both manuals before beginning installation.
9. Record the spa and equipment pack serial number on the inside front cover of the Owner's manual. (See illustration on page 2 for the serial number location.)
10. When unpacking optional equipment, keep enclosed literature for owner's reference.

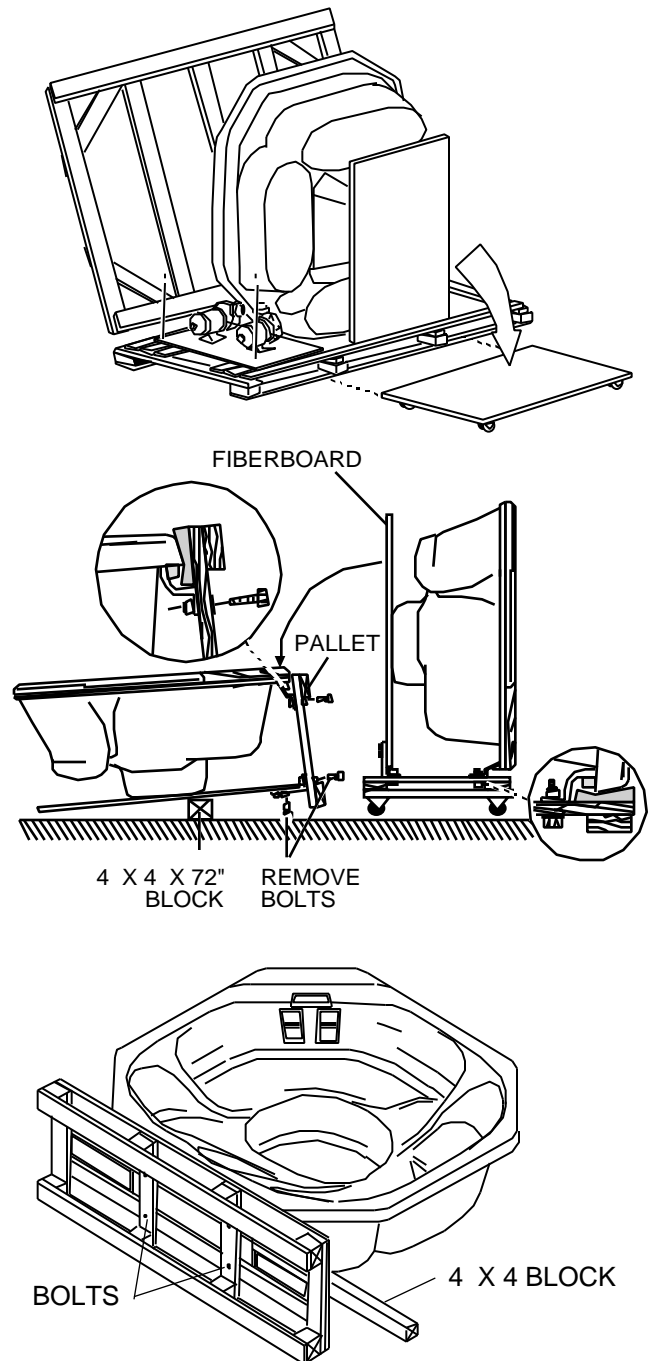

INSTALLATION

Indoor Installation

Support

If you install your spa indoors, be sure to provide proper support. The spa is very heavy when filled with water and in use. The floor or deck it is placed on must be capable of supporting a 4345 lbs. load, which includes weight of the spa occupants, water and product. Consult an architect or engineer to determine the adequacy of your floor or deck to support this amount of weight. The Spa seating area and foot well must be fully supported. Construct four 12 3/4" X 34" supports from 2 X 6 redwood or equivalent decay-resistant or treated wood. The dimensions given are approximate; supports should be cut to fit tightly between the seat area and the floor. Locate the supports as shown in the illustration on the inside front cover. **Do not fill the spa with water until the supports are installed.**

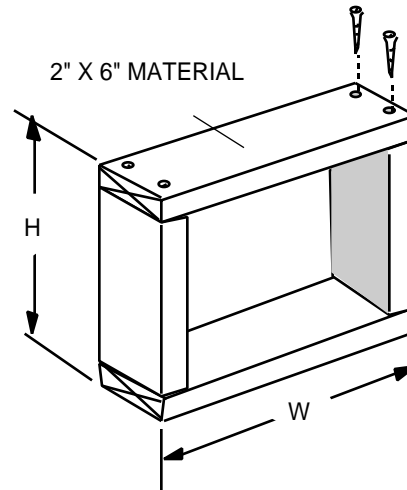

2" X 6" MATERIAL ~ REDWOOD OR WOOD TREATED TO RESIST DETERIORIZATION	
QTY	SIZE
2 @	11.0" H X 12.0" W *
1 @	9.25" H X 12.0" W *
1 @	9.50" H X 12.0" W *
1 @	6.25" H X 6.0" W *
1 @	6.50" H X 6.0" W *

* MATERIALS NOT PROVIDED

Draining the Spa and Equipment Pack

Two methods of draining a spa installed indoors are possible. You can install a permanent drain line in the suction line of the spa, extending from the spa to the house sewer line and using drain assembly fittings available at most hardware or plumbing supply stores. Another method is to install a drain valve in the suction line for hooking up a garden hose which can be run to the house sewer line or to an outside storm drain. Check local plumbing codes. See illustration below.

If you locate your equipment pack indoors, provide drainage for that as well. You can attach a garden hose on the hose bibb provided (once it is installed on the equalizer tube between suction lines at the pumps) and run it to the house sewer line when draining the equipment pack

Surroundings

Water which splashes on the floor during use may cause a walking hazard and/or structural damage unless good drainage is provided and proper building materials are used in the area surrounding and beneath the spa. Take into consideration, also, the high room humidity which will exist due to high spa water temperature. Providing natural or forced ventilation of the room will help maintain comfort and minimize moisture damage to the building. Jacuzzi Whirlpool Bath is not responsible for damage resulting from excess moisture or water spillage. Consult an architect or engineer for aid in designing your indoor installation.

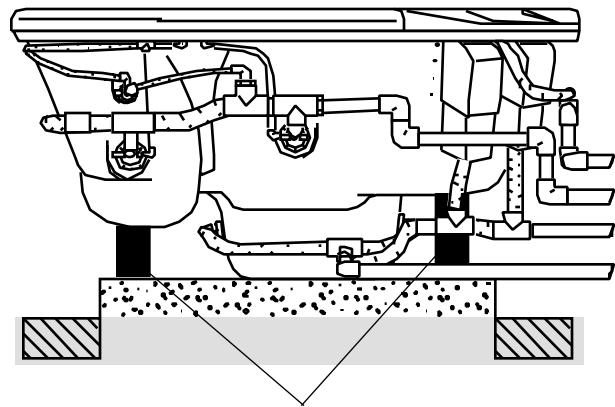

WOODEN SUPPORTS

*PARTS SHOWN ARE NOT PROVIDED

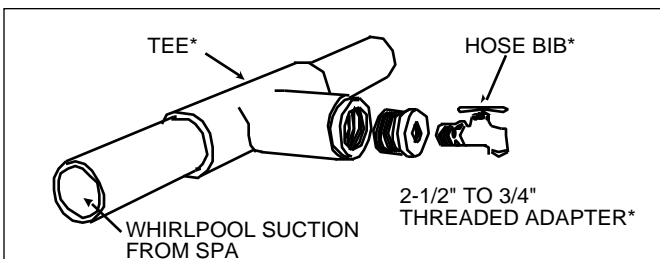

DRAIN HOSE HOOK-UP

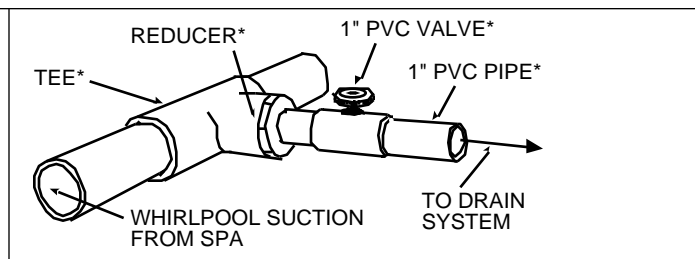

PERMANENT DRAIN ASSEMBLY

INSTALLATION

Outdoor Installation-Below Ground

The overall length of plumbing between the spa and the equipment pack must be less than 20 ft. If you are installing your spa below ground level, the base of the equipment pack must not be more than 9" above the spa rim.

Your spa should be installed so that the air intake opening on the air control assembly is not obstructed by backfill or insulating material. If, however, your installation will cause the air intake to be restricted because of such obstruction, we recommend that you construct a protective baffle around the intake to provide a fresh air passage to it.

Backfill Method

If your ground water level is low and drainage is good, you may use the backfill method to install your spa.

Dig a pit 6" deeper than the planned height of your spa and 6" around the outside walls. Since backfilling is below grade, you should also trench out a plumbing run to the equipment pack at this time. Fill the bottom of the pit and level it. Make sure the spa is at the desired height. All plumbing connections should be made at this time.

The plumbing system should be tested before completing backfill. (See "Plumbing.") Backfill beneath seat area and perimeter, wetting the sand occasionally. **Important:** Use care when backfilling, both to avoid system damage and to prevent sand from entering the air line system. The backfill should fully support the underside of the seat area and sides. Finishing material around the spa, such as decking or patio, should not extend beneath the spa rim in such a way that the spa rim, after shifting or settling of backfill sand, would become the main support of the spa. The spa rim is not designed to support the weight of the spa. If the rim **does** support the spa, irreparable damage might occur which is not covered by the warranty.

Note: Do not use the backfill method if ground water level is high or drainage is poor, as hydrostatic pressure may lift the spa out of the ground. If, because of heavy rains, the ground water level is temporarily high, ensure that the spa is filled with water (except when cleaning) to compensate for the lifting force.

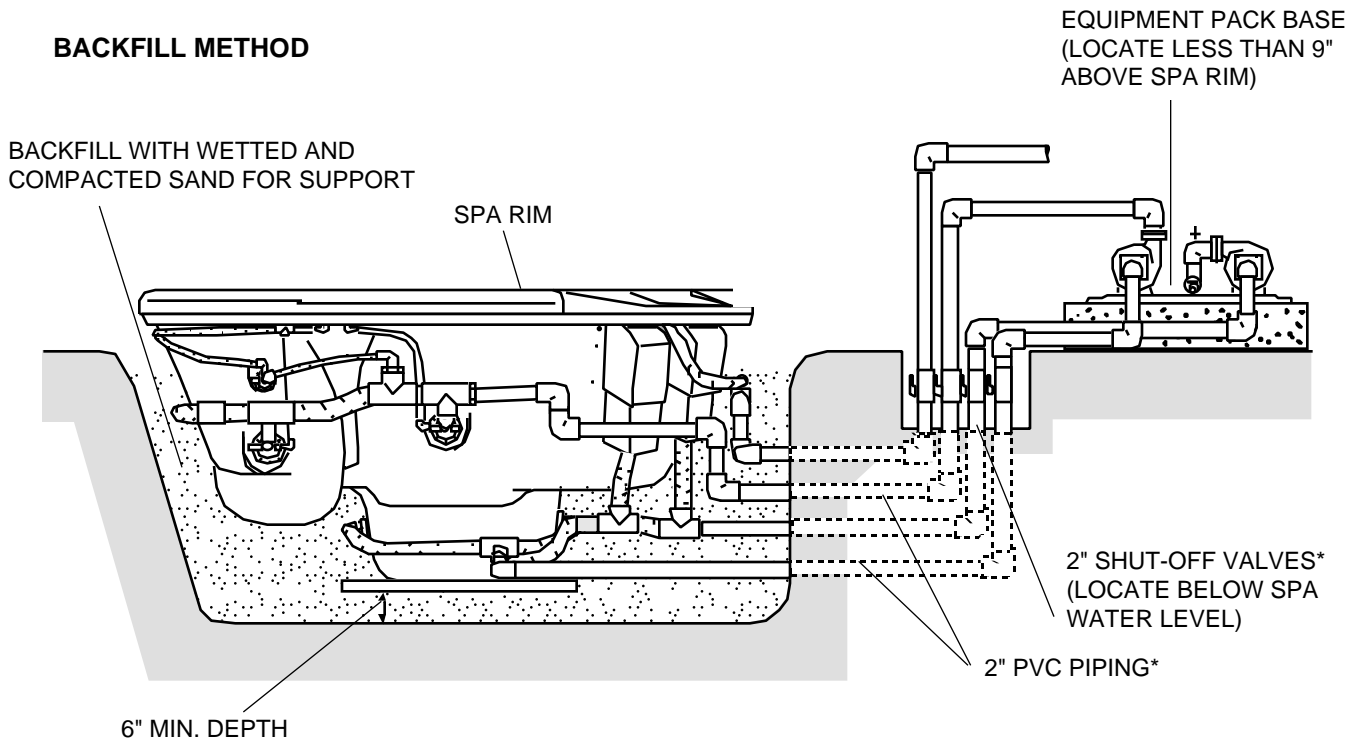

Do not cover piping that is to be enclosed until having completed a 24-hour leak test. Verify that the spa and system, once filled with water and primed, are water-tight for a 24 hour period before covering piping.

*NOT PROVIDED

INSTALLATION

Outdoor Installation — Below Ground (Continued)

Support Method

If your ground water is high and/or is poor, you will need to build a concrete pad at the bottom of the pit to support your spa and prevent movement and slippage.

Build forms for a 60" X 72" X 4" thick level concrete pad. Install a #10 gauge wire 6" X 6" steel reinforced grid. Then pour concrete. Build wooden supports and fit them under the spa seating area as instructed in "indoor Installation." Refer to "Support Method" illustration.

Draining the Spa

The spa can be drained to the level of the suction fittings if connected to a drain line or a gravel drain field. Whether the spa is installed on a concrete pad or in a backfilled pit, install an accessible drain valve in the suction line and run a drain pipe to a dry well, gravel drain field or storm drain. (See illustrations of suggested drain valve fittings on page 4.) If your spa is installed lower than any drain field or storm drain, then it will be necessary to drain the spa by hand or by means of an electric pump. When using an electric pump, observe caution and use a grounded cord, preferably with a plug-in GFCI (Ground Fault Circuit Interrupter) available at your local hardware or electrical supply store. For maximum safety, do not use an electric pump while the spa is occupied.

Air Blower Option

In the event that the air blower option may be added by the owner at a later date, we recommend that piping be stubbed out from the air channel at this time. (See Optional Air Blower section.)

SUPPORT METHOD

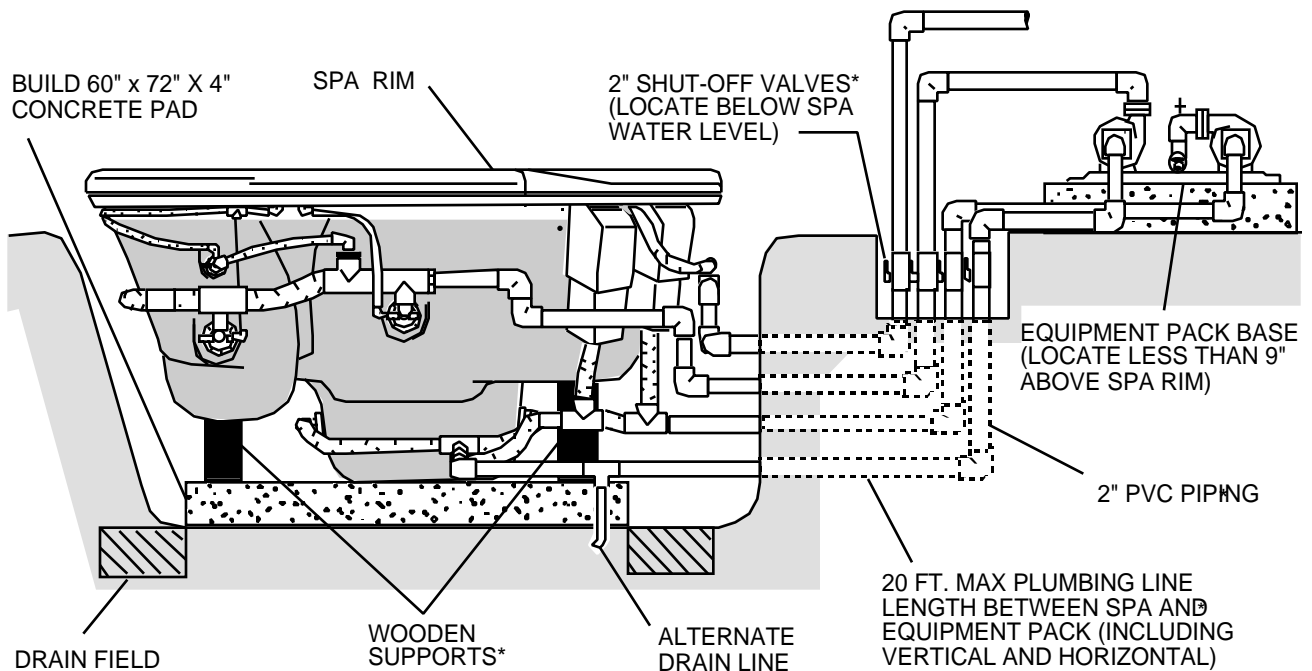

* NOT PROVIDED

Do not cover piping that is to be enclosed until having completed a 24-hour leak test. Verify that the spa and system, once filled with water and primed, are watertight for a 24 hour period before covering piping.

INSTALLATION

Outdoor Installation — Ground Level or Above

You may install your spa and equipment pack so the spa is at ground level or above. The unique characteristic of the equipment pack, which allows your spa system to be located away from the spa itself, is that it is designed to allow flexibility in installation. This means that you can locate your spa on a level higher than the equipment pack, as long as the total combined horizontal and vertical length of the plumbing lines between the equipment pack and the spa is no more than 20 feet, and as long as the equipment pack base is less than 5 feet below the spa rim.

Support Method

Particularly in deck installations, make sure the floor supporting the spa is strong enough to bear the load of the spa, which is approximately 4345 lbs. which includes weight of spa occupants, water and product. Consult an architect or engineer to determine the adequacy of your floor or deck to support this amount of weight. Build wooden seat supports as instructed in "Indoor Installation".

Draining the Spa

As in other installations, you can install a permanent drain valve in the suction line; this will allow the spa to drain into a sanitary drain, storm drain, or drain field, (See illustrations of suggested drain valve fittings on page 4.) Consult local codes.

GROUND LEVEL

20 FT. MAX. PLUMBING LINE LENGTH BETWEEN SPA AND EQUIPMENT PACK (INCLUDING VERTICAL AND HORIZONTAL.)

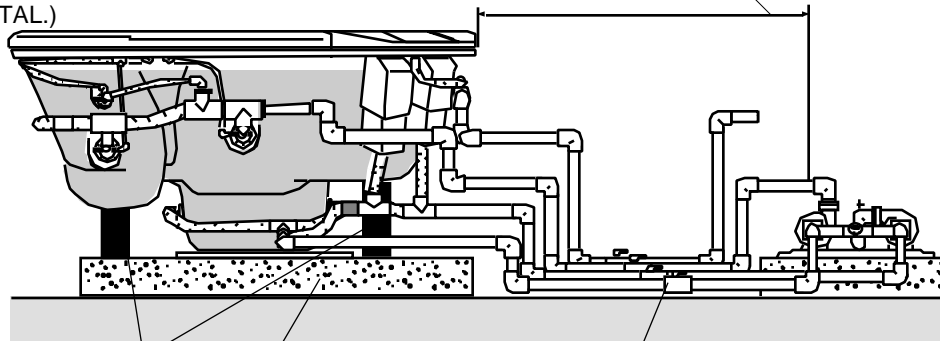

WOODEN SUPPORTS* CONCRETE PAD* 2" SHUT-OFF VALVES* (LOCATED BELOW SPA WATER LEVEL) *NOT PROVIDED

ABOVE GROUND LEVEL

20 FT. MAX. PLUMBING LINE LENGTH BETWEEN SPA AND EQUIPMENT PACK (INCLUDING VERTICAL AND HORIZONTAL.)

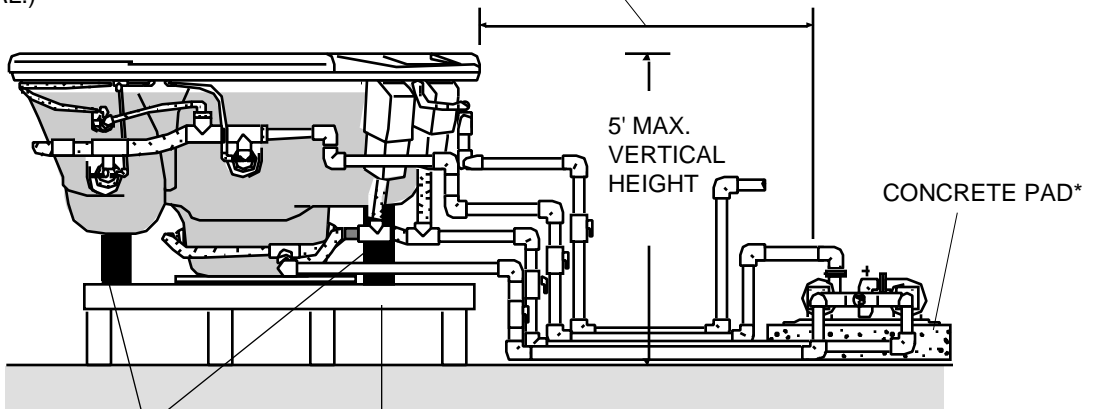

WOODEN SUPPORTS* SEE "SUPPORT METHOD" REQUIREMENTS ABOVE *NOT PROVIDED

SEE PAGE 5 (BOTTOM PAGE, BOLD TEXT)
FOR "24-HOUR I FAK TEST"

INSTALLATION

Equipment Pack Site Preparation

Locate the equipment pack on a level surface (at least 5 feet but not more than 20 feet from the spa) where there is sufficient access to the equipment. Make sure the site selected will allow drainage of water away from the equipment pack. We recommend that you build a concrete pad for the spa equipment. If an electric heater is to be used, the pad should measure 48" X 24" X 3" thick; if a gas heater is to be used, make the pad 60" X 36" X 3" thick.* The heater must be located within 5 feet of the equipment pack and on the same level. The pad should be reinforced with 6" X 6" #10 gauge steel wire mesh grid. Attach a #12 solid copper wire to the wire mesh grid with a ground clamp. This wire should be long enough to reach the bond bar (See "Bonding" in the section on Electrical Service.)

After pouring concrete, and before it has set, locate holes for bolts or anchors to secure the equipment pack based to the pad. Refer to the hole locations on the flange of the equipment pack base. Then secure the equipment pack base to the pad. See illustrations on this page for details.

* Refer to heater manufacturer's installation instructions for proper placement and clearance around the heater, as well as proper plumbing methods. Adjust pressure setting on heater according to manufacturer's instructions, if so equipped.

RECOMMENDED EQUIPMENT LAYOUT

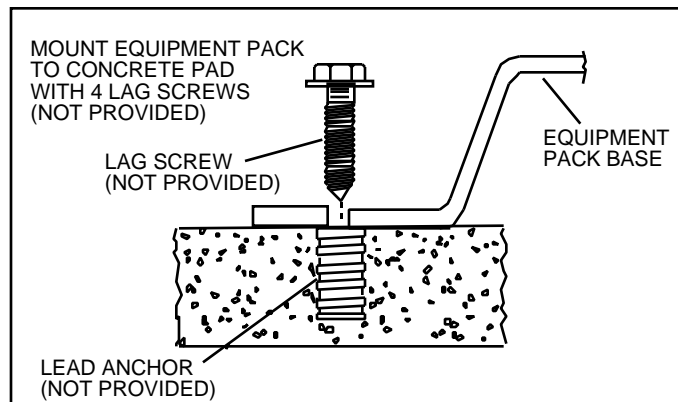
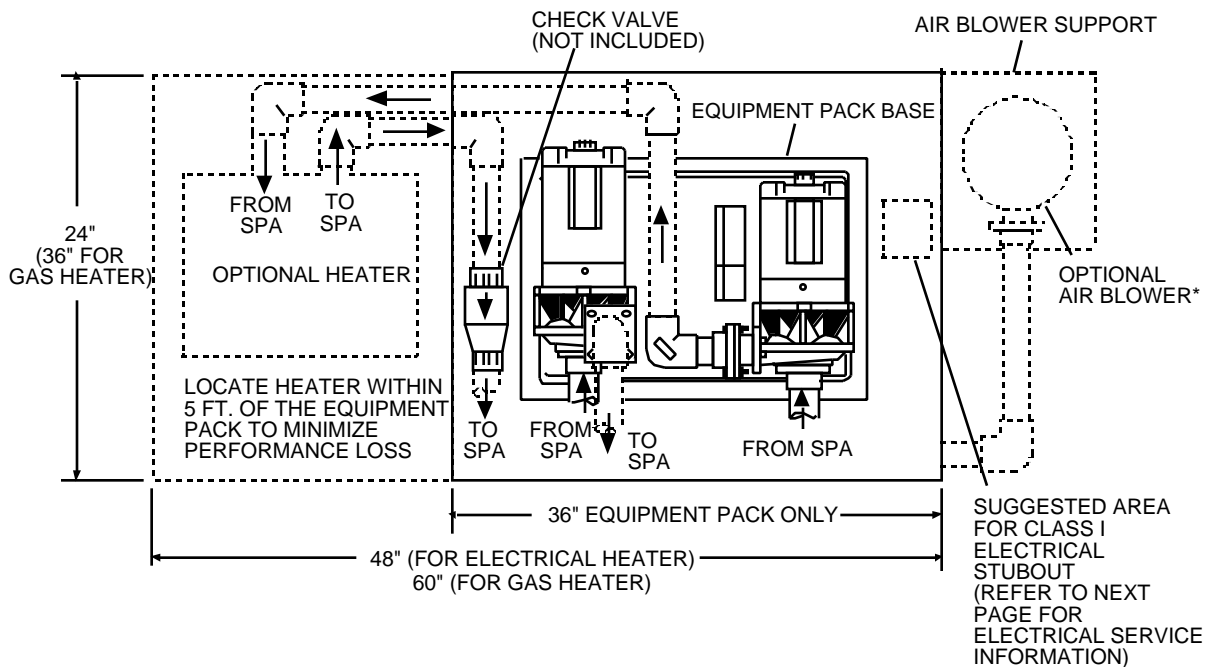

INSTALLATION

Electrical Service

Since most spa owners are not usually qualified to install the electrical hook-up to the equipment pack, we recommend that you hire a professional electrician for a completely safe and functional installation. You or your electrician should obtain whatever electrical permits may be required in your community and have the finished installation inspected by the local building or electrical inspector. Consult your local building inspection department to determine local requirements. Your electrician must size the wires to provide adequate amperage and voltage at the equipment pack. The type of wiring insulation, amperage requirement, and distance from the service panel will determine the wire size (minimum 12 gauge recommended). See also sections on grounding and bonding.

You will need to purchase a means of controlling your spa equipment pack. We recommend that you install an air switch/timer such as that available as an option from your Jacuzzi Whirlpool Bath dealer. Follow switch manufacturer's instructions when installing and refer to addendum sheet included with this product for wiring information. Provide a separate 230 VAC/15AMP circuit to supply power to each of the motor/pumps. Additional circuits will be needed for any auxiliary equipment, such as electric heater, air blower or chlorinator.

Note: When installing power wiring to the motors, refer to wiring diagram on motors or behind connection plate.

Bonding

Using a #8 solid copper wire, connect the equipment pack motors, current collector pipes (if an electric heater is used) and air blower (if used) to a local bonding bar. Also connect all fixed metal objects (metal railings, window frames, greenhouse structures, lamp poles, fence posts and gutters within 5 feet of the spa to the local bond bar. The local bond bar must be connected to the house sub-panel or main electrical panel with a #8 solid copper bond wire. Consult your local building inspection office for requirements. (See National Electrical Code Article 680-22.) Bonding lugs are available at your local electrical supply store.

Grounding

The continuous service ground (minimum #14 copper) must run inside the electrical supply conduit from the main service panel to the ground terminal in the equipment. **Approved Local Ground.** An approved local ground may be an 8 ft. long ground rod, a ground plate electrode, or a buried metallic water pipe with at least 10 ft. or more of buried pipe. See Article 250 of the NEC or consult your local building code for additional approved grounding methods.

CAUTION

Your equipment pack is an electrical device. It has been made to operate as safely as possible with many safeguards designed in. It complies with the NEC (National Electrical Code). It must be installed at least 5 feet away from the spa and grounded properly in order to maintain these safeguards. (See "Approved Local Ground".) All fixed metals within 5 feet of the spa must be bonded (see Bonding). Electrical receptacles must be at least 10 feet from inside the rim of the spa and be of a GFCI (Ground Fault Circuit Interrupter) type, or in a GFCI circuit. Area lighting must not be located over the spa and must be at least 5 feet horizontally away from the spa rim, at least 5 feet above the floor or ground. If within 10 feet of spa, it should be in a circuit protected by a GFCI (see National Electrical Code, Article 680-6).

Without proper grounding and bonding, a system malfunction may cause fatal shock!

INSTALLATION

Plumbing

Preliminary Assembly

Once your equipment pack is installed, attach the suction equalizer tube assembly provided to the suction inlets of the pumps. Align pump flange ends of the assembly and install using gaskets, bolts and washers provided. Next, install the 1 1/2" x 3/4" reducing bushing and hose bibb provided onto the tee on the equalizer tube. This hose bibb can be used to drain the equipment pack, and if a garden hose is attached between it and your water supply, it can help when priming the pumps. Be sure there is an anti-siphon valve in the water line to prevent fresh water contamination. Screw-on anti-siphon valves are available for easy installation on the house water spigot.

Install the two ells to the clear plastic pipes at the discharge outlets of the pumps, orienting them in the direction appropriate for your plumbing layout. Note that each ell has a predrilled hole so you can install the two air vent valves provided. These are necessary to bleed air from the lines during priming. Install the air vents at this time.

Interconnecting Piping

Plumbing lines between the equipment pack and the spa must not be longer than a total of 20 ft., including vertical and horizontal dimensions.

Use 2" schedule 40 PVC pipe, with as few fittings as possible and bond with PVC solvent cement. When laying out plumbing lines, avoid making configurations which might cause air entrapment in the system. Four 2" shut-off valves (not provided) must be installed as close as possible to the equipment pack unit, below the spa water level, and accessible for normal operation and maintenance. We recommend that they be ball-type valves. Do not use excessive amounts of cement when bonding the valves to piping. Use pipe primer where required by local codes or when the air temperature during installation is below 70 degrees F.

Install 2" check valves (swing type) supplied with the spa in the suction line to each pump. These aid in priming and prevent reverse flow through the heater/filter pump when only the whirlpool pump is running. The arrow on the side of the check valves must point in the direction of flow. If the base of the equipment pack is to be situated more than 20" higher than the bottom of the spa shell, locate the check valves in the vertical part of the lines, near the pump.

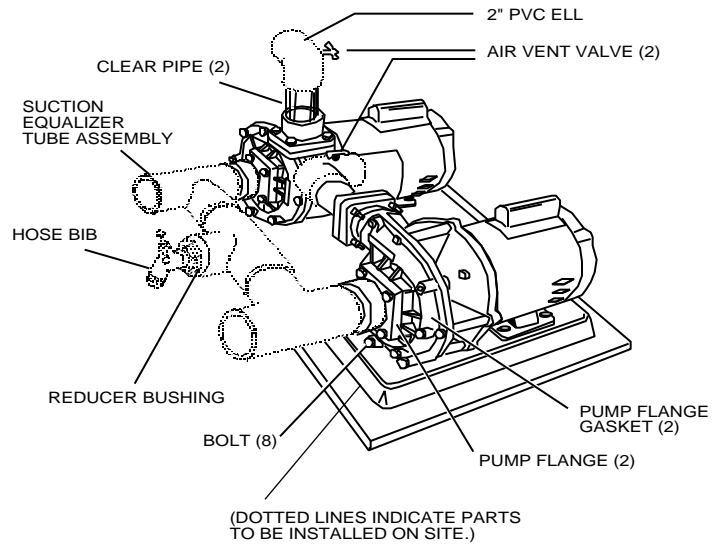

EQUIPMENT PACK PRELIMINARY ASSEMBLY

EQUIPMENT PACK WITH PIPING

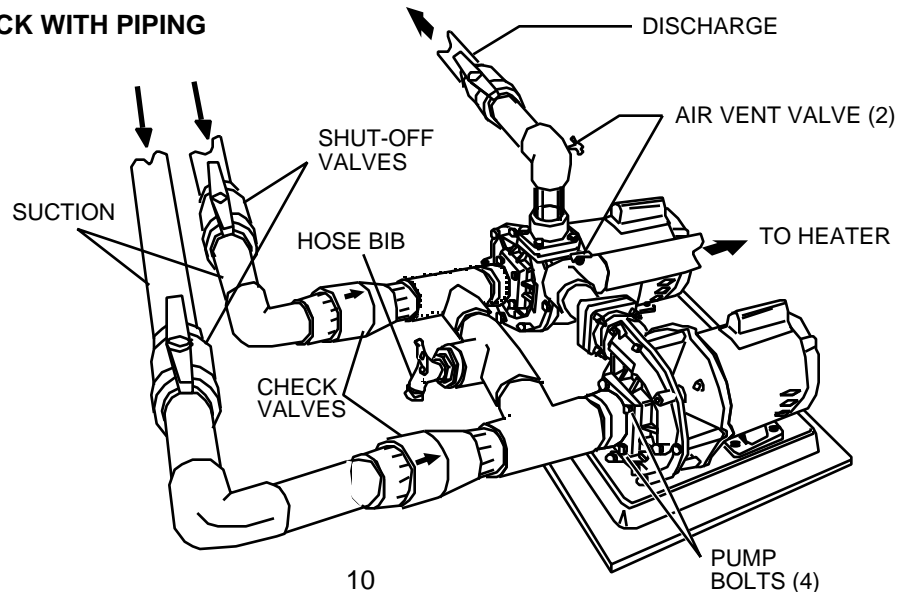

INSTALLATION

PLUMBING LAYOUT

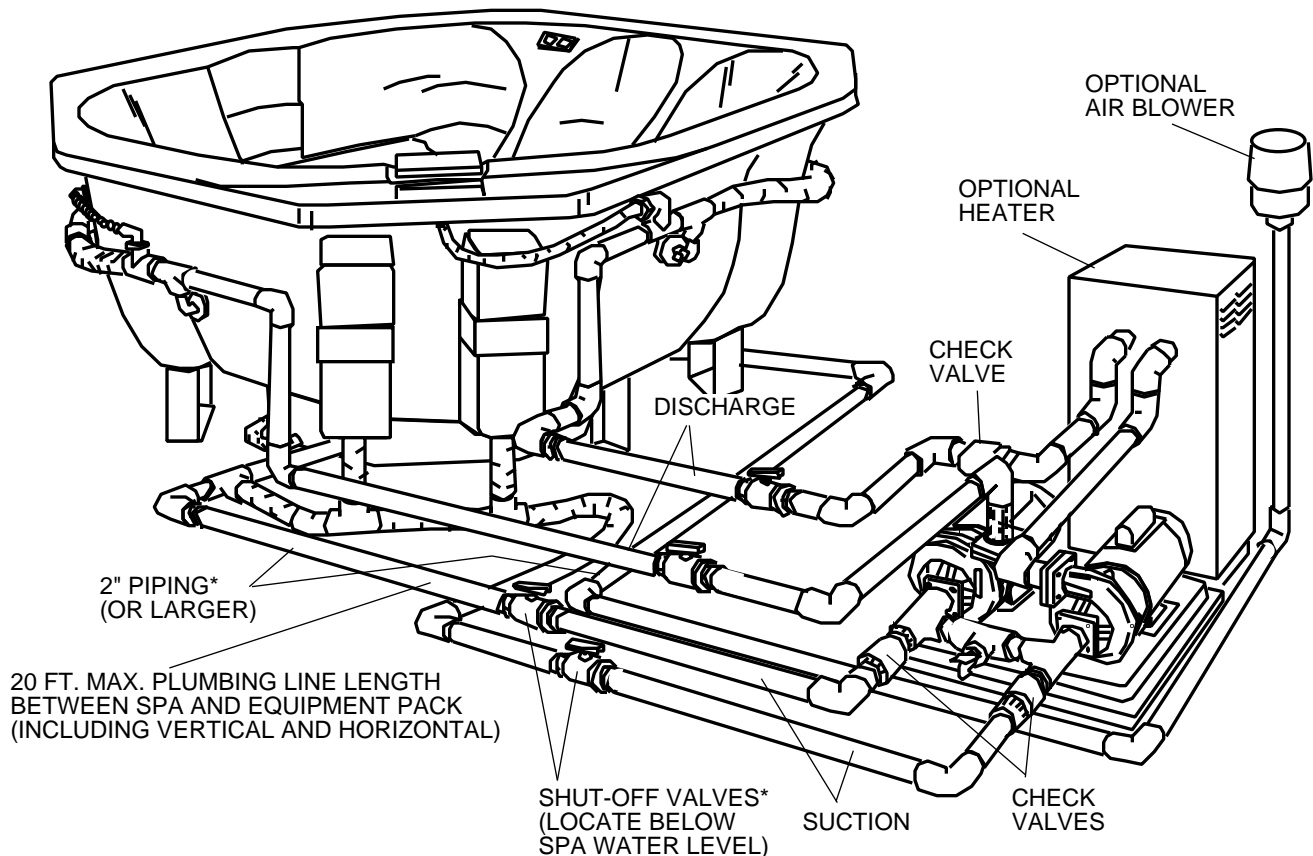

*SHUT-OFF VALVES AND PLUMBING LINES
NOT PROVIDED BY JACUZZI WHIRLPOOL BATH

Heater Plumbing

Use at least 4 ft. of copper pipe in the inlet and outlet plumbing of a gas heater (refer to local codes). Install a current collector in each water line to the heater if an electric heater is used. Piping should be 1 1/2" or larger. You must install a swing check valve after heater discharge. To minimize performance loss, locate the heater no farther than 5 ft. away from the equipment pack and at the same elevation. Refer to heater manufacturer's instructions and the "Recommended Equipment Layout" on page 8.

Air Channel Plumbing

Use 2" PVC schedule 40 pipe for the plumbing line between the optional air blower and the 2" fitting located under the spa near the skimmer wall. See page 12 for detailed air blower instructions.

Automatic Chlorinators

There are several brands and types of automatic chlorinators available. Automatic chlorinators should be installed downstream of the heater (all types) with a check valve in the line to ensure that the chlorine solution does not enter the heater and cause corrosive damage. Your Jacuzzi Whirlpool Bath dealer will be glad to assist you in making your selection.

Note: Use of an automatic chlorinator does not ensure proper water quality. Check and adjust water quality frequently to prevent corrosive damage, which is not covered by the Jacuzzi Whirlpool Bath warranty.

INSTALLATION

Optional Air Blower

Two channels under the seating area of your Cirrus IG receive air from the air blower and distribute the air throughholes in the seating area (to be drilled according to instructions on the following page). As the pressurized air is released from the holes, tiny bubbles are formed. These bubbles travel upward through the water and expand until they reach the surface, whereupon they burst. The visual effect of the bursting bubbles contributes to the overall hydromassage experience.

Consult your Jacuzzi Whirlpool Bath dealer for the air blowers available. The minimum rating of the air blower you use should be 110 cfm, 2.6 psi. For best performance, the blower you select should not exceed this rating by more than 10 percent. See the illustration on page 8 for its recommended location. A bottom discharge blower should be mounted directly onto a vertical 2" diameter PVC pipe (see illustration on this page). Side discharge blowers that are installed lower than 12" above the spa's rim must be plumbed with a loop, as illustrated on this page. Some air blower manufacturers recommend that a check valve also be installed, but use of a check valve instead of a loop is not recommended. Follow blower manufacturer's instructions when installing.

CAUTION: Wait 24 hours before turning on the air blower, as the PVC cement fumes remaining in the plumbing are flammable and may explode when the blower is started.

SIDE DISCHARGE BLOWER

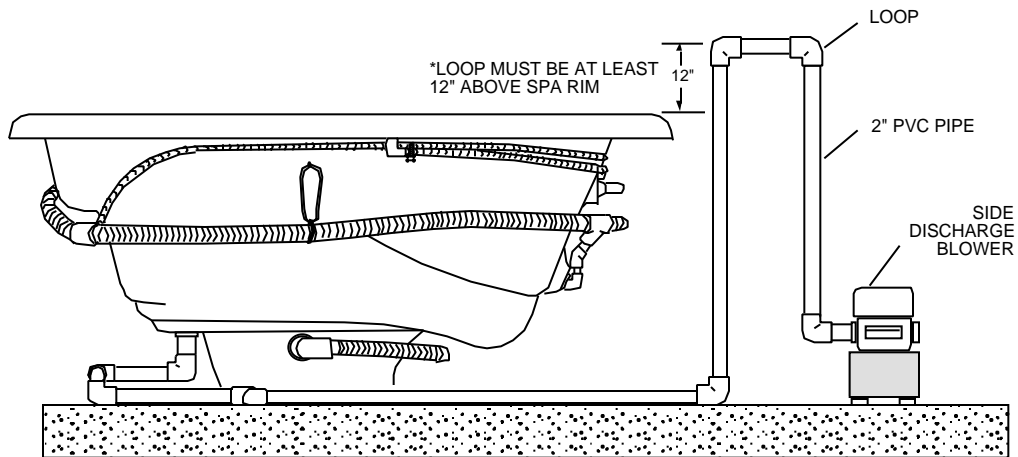

TYPICAL BOTTOM DISCHARGE AIR BLOWER ORIENTATION

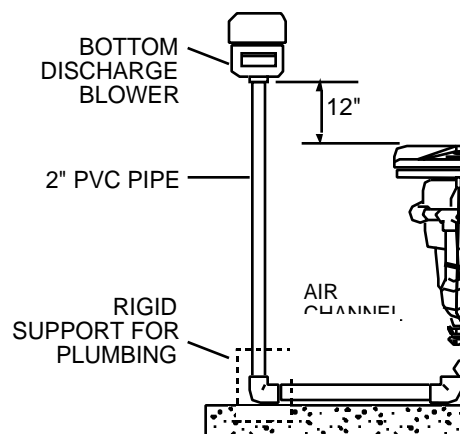

INSTALLATION

Seat Air Holes

Because the air blower is an optional feature of the Cirrus IG, air holes are not factory drilled in the seating area. Included with your spa are an air hole drill guide and a 5/32" diameter drill bit with which to drill the 59 holes required. The drill guide is shaped to fit the contour of the spa. We recommend that you apply masking tape to the underside of the guide to prevent scratching the spa surface.

Locate the dimples imprinted in the surface of the seat. (The dimples indicate the center of the air channel located beneath the seat.) Align the drill guide so that it fits the contour of the spa and is positioned against the footwell wall, and the hole is over one of the dimples.

Insert the drill bit provided into the drill chuck so that only 1" to 1 1/2" of the drill bit extends out of the chuck. With the drill guide in place, insert the bit into the guide and proceed to drill with light pressure at low speed through the acrylic, increasing to high speed to drill through the fiberglass. Continue marking and drilling holes around the seat of the spa until all holes are drilled at 1 3/4" intervals. (See illustration below.)

Use care when drilling! Failure to use the drill guide or drill bit provided may cause the bit to drill through bottom of the air channel or cause permanent damage to the shell.

SEAT AIR HOLE DRILLING (WHEN OPTIONAL AIR BLOWER IS INSTALLED)

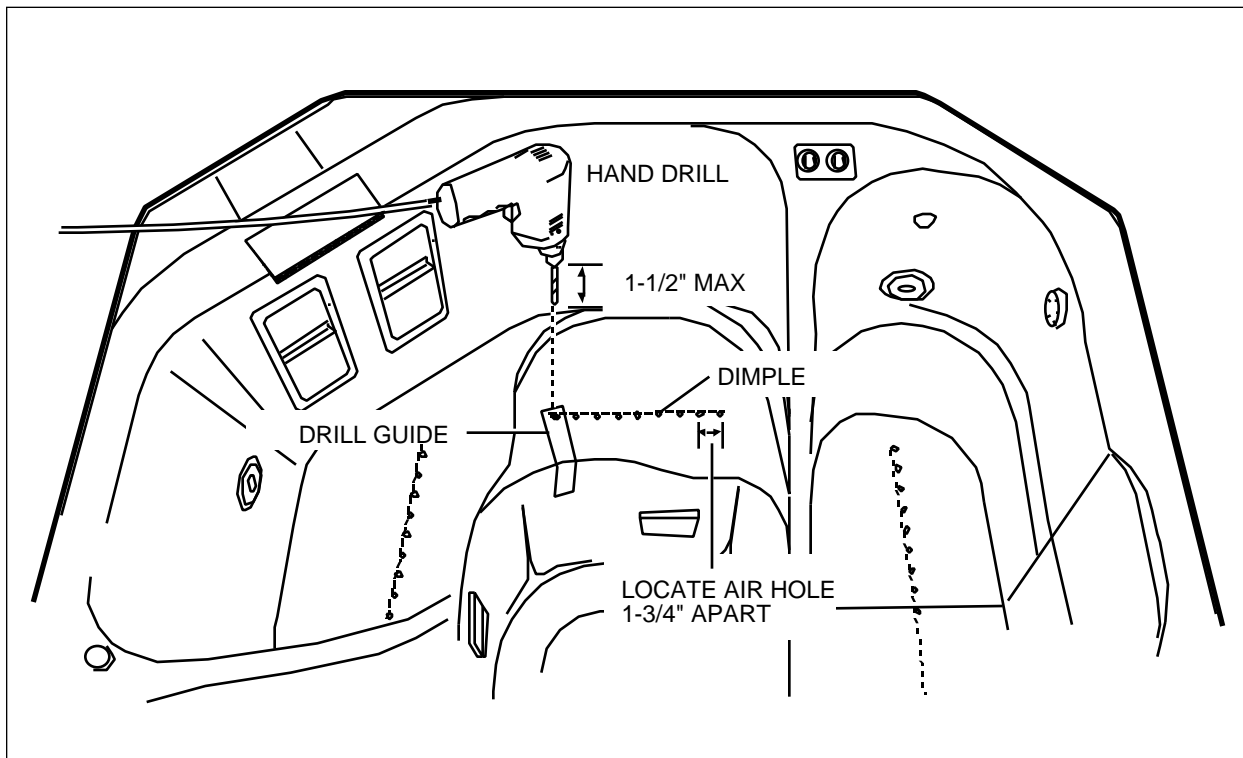

*Number and size of the holes may vary if a blower other than that recommended on page 12 is used.

INSTALLATION

Spa Set-Up

Remove the protective plastic rim cover on the spa. Use care. Stepping into the spa with shoes will scratch the acrylic surface.

Remove any packing materials from the spa.

Remove each filter cartridge and skimmer basket from plastic bags.

Pull open each skimmer/filter door by the handle located in the middle of the door. Insert the filter cartridge into the filter housing and insert the skimmer basket so it is in place over the filter cartridge. Then close the skimmer/filter door.

Clean the interior of the spa of any remaining construction debris. Remove stubborn stains, paint or tar with turpentine, isopropyl alcohol or paint thinner. A mild liquid dishwashing detergent on a damp cloth is fine for cleaning off other dirt. Plaster can be removed by scraping with a wooden edge; do not use a metal scraper, wire brush, or other metal tools, as they will damage the spa's surface.

FRONT ACCESS SKIMMER/FILTER

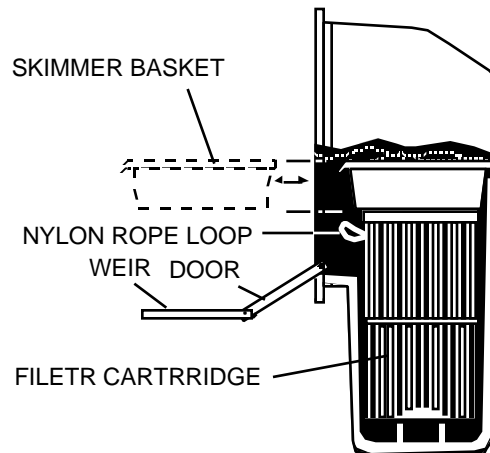

Alternate Use of Water Rainbow Spout as Fill Spout

You can use your Water Rainbow spout as a fill spout by permanently plumbing it to a fresh water supply if codes permit. Local plumbing codes may require the use of an anti-siphon valve for such a connection. **Do not interconnect water supply with recirculating system of the spa.**

To make the connections necessary to use the Water Rainbow as a fill spout, follow this procedure:

- Make sure power to the equipment pack is disconnected and spa is drained to below seat level.
- Cut 3/4" flexible piping as shown in illustration below and unscrew connecting fitting at spout.
- Cap off piping by cementing a 3/4" PVC cap where cut has been made.
- Connect permanent plumbing line to the spout.

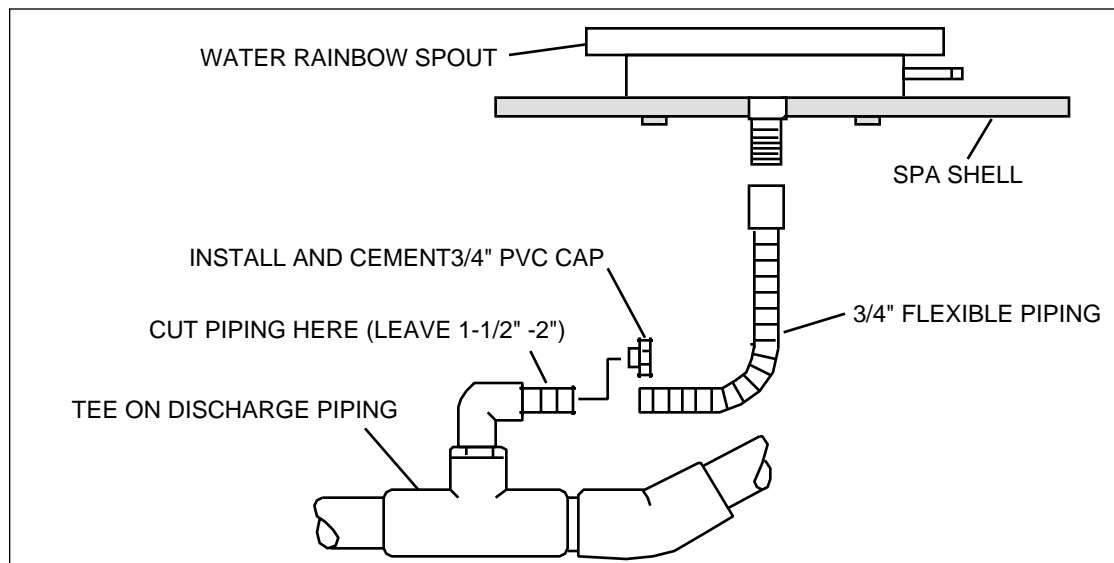

OPERATION

Equipment Set-Up

Important: Your spa equipment pack must have two professionally installed 230 VAC 15 AMP electrical circuits from your house electrical panel. Additional power will be required for optional equipment, such as heater, air blower, or chlorinator. A proper ground wire run to a ground approved by your local building or electrical inspector is also required. Make sure the equipment is properly bonded as instructed in Installation Instructions.

1. Turn OFF all power to the equipment pack by turning off circuit breakers at the main electrical service panel.

Warning! Turn off all power to the equipment pack before priming, draining the spa, or performing any equipment maintenance.

At no time should the whirlpool or filter pump motors be activated until the pumps are primed and the spa is filled with water to its normal operating level. Running the pump dry will cause irreparable damage to the pump, and the warranty will become void.

2. Turn on the circuit breakers at the service panel.

3. Follow Priming Procedure, I or II, depending on your installation type, and check pipes, pumps, and fitting for leaks.

4. Set thermostat at heater (see heater manufacturer's operating instructions.)

5. Test for proper water chemistry; then add treatment chemicals to ensure proper levels. See "Water Quality" section for details.

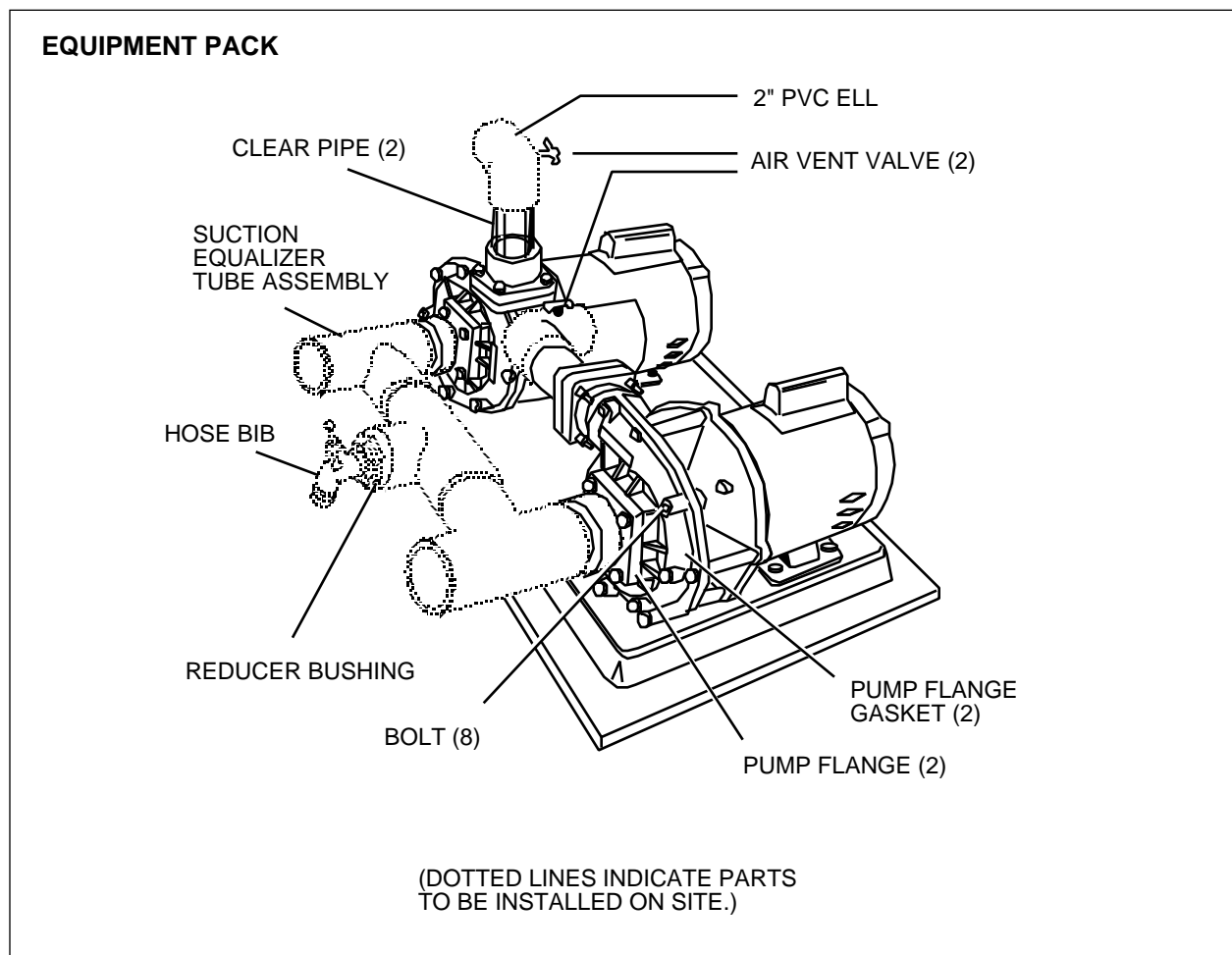

OPERATION

Priming Procedure I

Use this priming procedure if your installation is such that the base of the equipment pack is level with or above the rim of the spa (see illustration.)

1. Turn all switches to OFF. Turn OFF circuit breakers at service panel.
 2. Open the air vent valves on the plastic elbows.
 3. Fill the spa with water with a garden hose to the spa's normal operating level, which is at the water level indicator mark on the filter/skimmer frame.
 4. Close the four shut-off valves in the suction and discharge plumbing.
 5. Connect hose to hose bibb on the equalizer tube between the two pumps. (Make sure anti-siphon valve is installed at the water source to prevent contamination of the water supply.)
 6. Open the hose bibb and fill the piping system with water until water can be seen through clear pipes on discharge piping.
 7. Close the air vent valves when water starts to flow from them.
 8. Close hose bibb and disconnect garden hose.
 9. Open four shut-off valves in suction and discharge piping.
 10. Turn ON circuit breakers at the service panel.
 11. Turn ON pumps one at a time.
- Important: If either pump is not visibly pumping water at this point, turn off the motor immediately. Then repeat priming procedures steps.**

PRIMING PROCEDURE 1 (ABOVE WATER LEVEL)

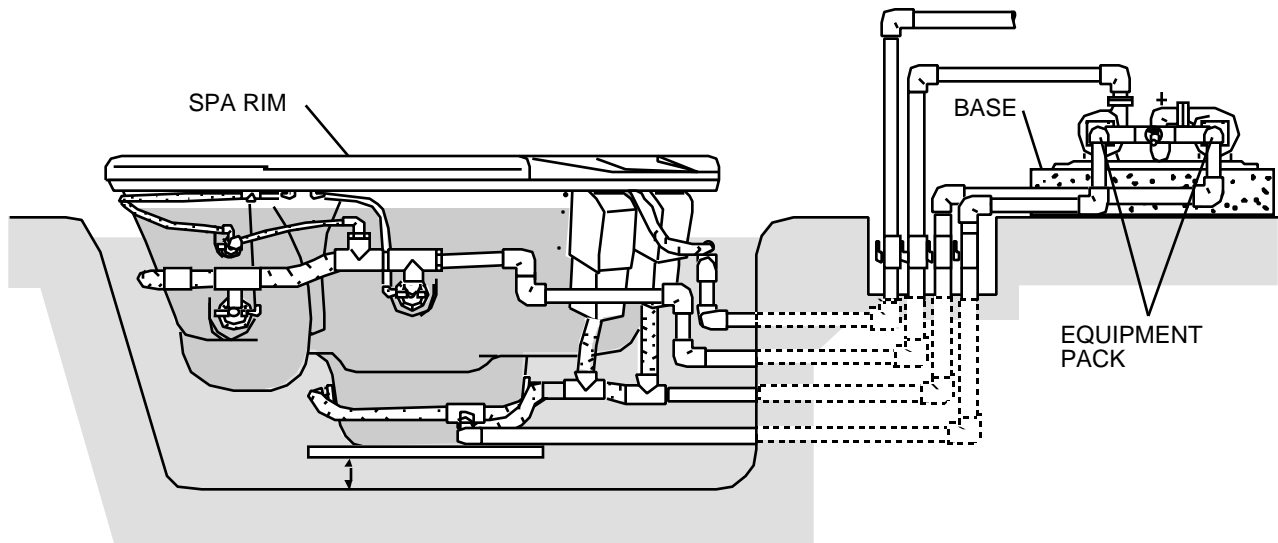

SHUT-OFF VALVES AND PIPING NOT PROVIDED BY JACUZZI WHIRLPOOL BATH

OPERATION

Priming Procedure II

Use this priming procedure if your installation is such that the base of the equipment pack is lower than the rim of the spa (see illustration.)

1. Turn all switches to OFF. Turn OFF circuit breakers at service panel.
2. Open shut-off valves in the suction and discharge system plumbing.
3. Open the air vents in the plastic elbows.
4. Close the hose bibb located in the equalizer tube between suction lines.
5. Fill the spa with water (using a garden hose) up to its normal operating level, which is at the water indicator mark on the skimmer/filter frame. As the water level in the spa rises, it will bleed air out of the vent valves. When water flows from the air vents, close them and continue filling the spa to water indicator mark.
6. Turn ON the circuit breaker at the service panel.
7. Turn ON the pumps one at a time.

PRIMING PROCEDURE II (BELOW WATER LEVEL)

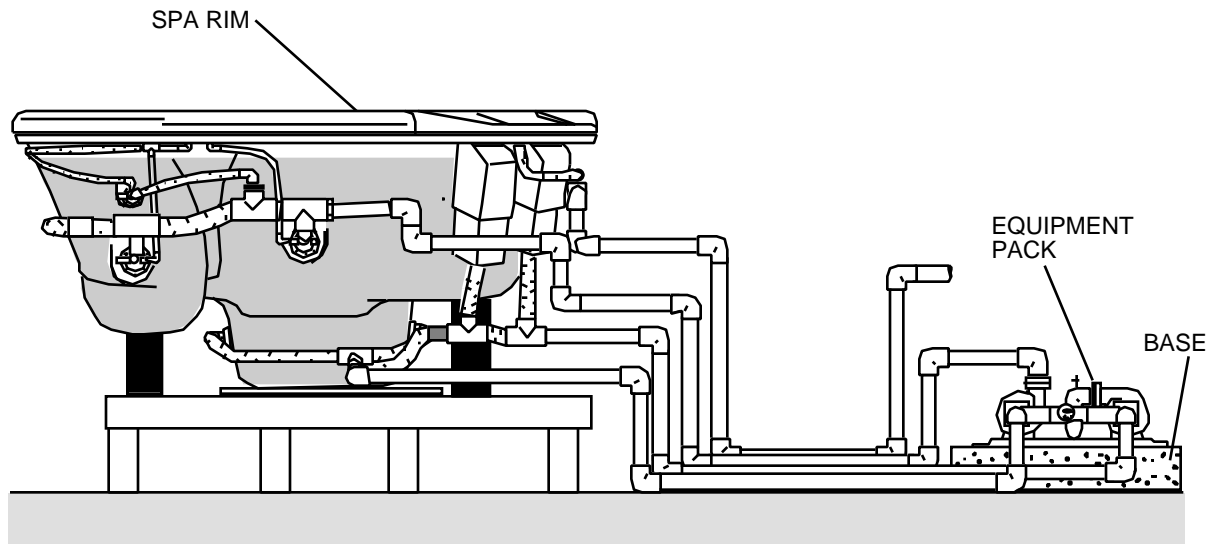

SHUT-OFF VALVES AND PIPING NOT PROVIDED BY JACUZZI WHIRLPOOL BATH

OPERATION

Spa Control

Your Spa and equipment pack installation must include a control system such as an air switch and/or timer system which will turn the two motor/pumps on and off and provide control of whirlpool, heater and filter functions. Follow switch manufacturer's instructions for operation.

Warning! At no time should the whirlpool or filter pump motors be activated until the pumps are primed and the spa is filled with water to its normal operating level. **Running the pump dry will cause irreparable damage to the pump, and the warranty will become void.**

All spa heaters have adjustable thermostat settings. The recommended water temperature range for whirlpool bathing is 90°-98° F. (104° F. max.) . Following the heater manufacturer's instructions, set your heater thermostat to a point which is comfortable for you within that range. (See Safety Information on the inside front cover.)

Normal Operation

Whirlpool System:

You can enjoy the Cirrus IG spa with or without activating the whirlpool. Either way, bathing in your spa can be pleasurable, as well as therapeutic. After a busy, stressful day, you can look forward to soaking in your spa in still water with no turbulence—only the gentle warmth of the soothing and relaxing water.

For a more invigorating spa experience, you can take advantage of the built-in whirlpool system. To do this, select the WHIRLPOOL mode at the system control switch. Sit or recline in the spa so you are comfortable. Since all the jets are directionally adjustable, you can direct a jet toward an area where muscles feel tense or stiff. The warmth of the water and the stimulating water flow from the jet will pleasantly increase circulation.

For the total whirlpool effect and all-over feeling of well being, you can adjust all jets so they point in a clockwise or counterclockwise direction to circulate the air and water mixture in a circular motion all about the spa.

DIRECTIONALLY ADJUSTABLE WHIRLPOOL JETS

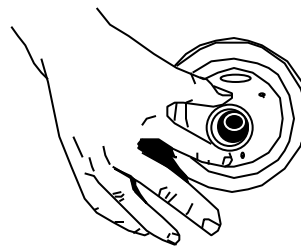

FULLY ADJUSTABLE WHIRLPOOL JETS

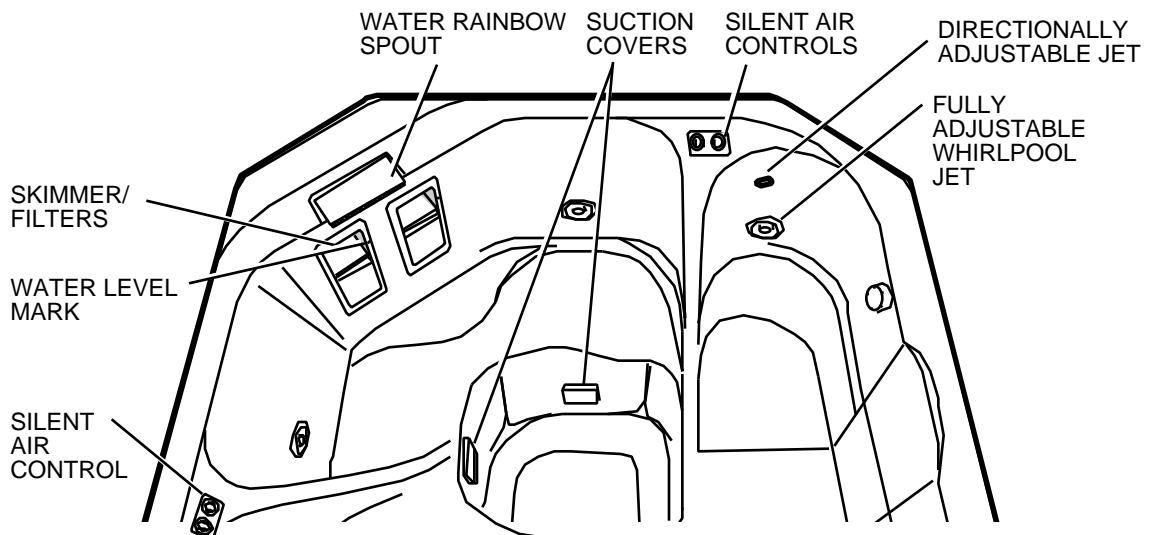

OPERATION

Water Rainbow™

The Water Rainbow spout will add the soothing sound of a waterfall to your bathing pleasure, as well as provide a beautiful cascade of shimmering water for an exciting visual effect.

Activate the waterfall feature by first turning on the WHIRLPOOL function, then rotate downward the flow control lever located on the left side of the spout. Use this lever to adjust the amount of water flowing through the Water Rainbow spout.

CAUTION: The water circulating through the Water Rainbow spout is not fresh water and therefore is not suitable for drinking.

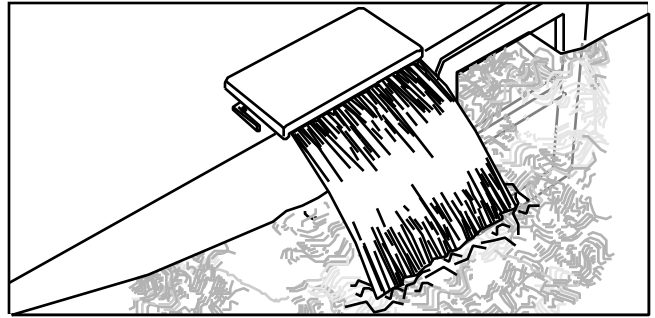

Silent Air Induction

The intensity of the whirlpool action is determined by how much air is induced into the water. You have control of this by adjusting the air induction control knobs (See illustration below). For maximum air induction, rotate each control knob fully counter clockwise. For fewer air bubbles, decrease the amount of air induction by rotating the control knobs clockwise. When the knobs are turned fully clockwise, only water is being circulated.

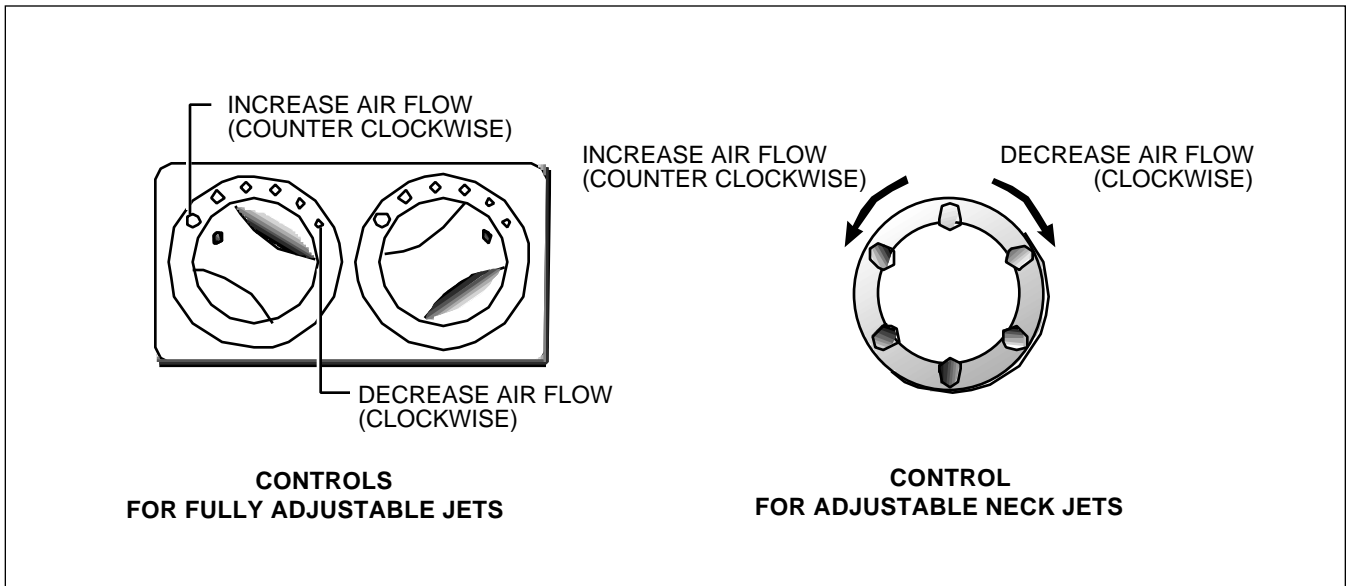

MAINTENANCE

Water Quality and Water Chemistry

Maintaining water quality and water chemistry in your spa is extremely important and should be a regular part of your spa maintenance program, as a neglected spa can be a breeding place for dangerous bacteria.

The water quality of your spa is maintained by a combination of filtration and chemistry. The spa's integral filter system helps maintain the water cleanliness and clarity by trapping most solid materials such as hair and other debris resulting from normal use. However, the most important part of maintaining water chemistry is keeping the proper level of disinfectant in the water at all times. This is accomplished by adding chlorine or bromine to the water, which will control particles too small to be trapped by the filter, such as bacteria and algae, and will oxidize any organic materials. Follow instructions provided here, and with water quality products, for the health and safety of spa users, as well as to make your spa bathing as enjoyable as possible.

Filtration

The filtration system of your spa will keep your water clear and clean if used properly. We recommend that you run your filter system for at least two hours each day. The filter cartridge elements will trap most solid materials and debris in the water. However, the presence of materials such as body oils or other particles which are too small to be captured in the filters may bring about various undesirable water quality conditions. These conditions can be corrected with the use of spa treatment chemicals which are available from your Jacuzzi Whirlpool Bath dealer. Such conditions include the following:

Foaming: A de-foamer is available to minimize foaming of the water. This condition is usually caused by the addition of soaps or oils, or other fatty substances to the spa water. The interaction of these with hot water, especially at high pH (more alkaline) levels, will cause the water to foam. (See Water Quality Definitions.)

Oil Film or Cloudy Water: Add clarifier to congeal oil film on the water surface into globules sufficiently large to be trapped by the system's filter. Cloudiness is caused by particles that are too small to be trapped in the filter and is also due to the presence of human body oils, lotions, and cosmetics. During normal use, these materials can accumulate on the filter element and clog its pores. The addition of clarifier will make the water clearer, but may clog filters which must be cleaned as prescribed under the section entitled "Filter Maintenance" in this manual.

Hard Water: Add a de-mineralizer to break down or de-ionize mineral particles present in the spa water.

Follow the "Filter Maintenance" procedure described in this manual to ensure optimum performance of your spa's filtration system.

Water Chemistry

You can ensure better water chemistry by testing your spa water every day and adjusting the chemical balance frequently. Obtain a water quality test kit, designed especially for spas, from your Jacuzzi Whirlpool bath dealer. The test kit must be of the type which allows you to test for the disinfectant (chlorine) level, pH, and total alkalinity. Make sure, also, that the chemicals used in your spa are especially for spa use, and not for swimming pool, as water quality maintenance of spas and swimming pools is very different.

Set up a daily program at first to check the disinfectant level, pH, and total alkalinity of the water to familiarize yourself with the amount of chemicals to add and to determine how often to make chemical adjustments during normal use. Remember that the more heavily the spa is used, the more often you should check the water chemistry.

When adding any chemicals, always run the filter system to ensure complete dilution with the water. **DO NOT ADD CHEMICALS DIRECTLY IN THE SKIMMER OPENING.**

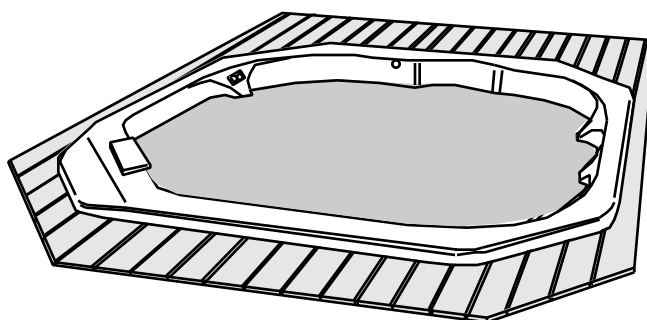

MAINTENANCE

Water Chemistry (continued)

Disinfecting:

Add a disinfectant to the water on a regular basis to help control the amount of bacteria, algae and organic materials. Such bacterial contaminants, if not controlled, could cause skin rashes or other physical problems. To disinfect the spa for normal use, first establish the amount of chlorine or bromine to add and determine how often you need to add it.

We recommend that you maintain a free chlorine level of 2.0-5.0 ppm at all times except when you must exceed that during the initial purge/sanitizing procedure or during superchlorination (see "Water Quality Definitions" below). Superchlorinate your spa every two weeks with heavy use. If using sodium dichlor, add one heaping tablespoon for each 150 gallons of spa water. Scrub the spa surfaces with this solution to remove any oily deposits. This will ensure that any bacteria or algae which are resistant to the normal disinfectant level are killed. After adding the disinfectant, run the filter system and allow the free chlorine level to return to the 2.0 to 5.0 ppm range before using the spa again. **Do not install a rigid cover until the disinfectant level is back to normal. High concentrations of chlorine or bromine will damage metallic plated finishes if the cover is in place.**

Balancing pH:

For good hygiene and equipment longevity, maintain the pH of your spa water according to the instructions provided. pH is the measure to determine if the spa water is too acid (low pH) or too alkaline or basic (high pH). The ideal range for spa water is 7.2 to 7.6 pH. For excessive acidity (below 7.2 pH) add soda ash or sodium bicarbonate to the spa water. For excessive alkalinity above 7.6 pH add dry acid to the spa water. **Caution:** Refer to the spa chemical manufacturer's instructions for the initial amount of chemicals to add for the gallonage of your spa. Low pH can cause equipment damage, as acidic water will dissolve metals, while high pH can cause scale or calcium deposits to build up in the system or on the shell. After adding chemicals, run the filter system for at least 30 minutes before testing water quality again for accurate readings.

Balancing Total Alkalinity:

Total alkalinity is the measure of base materials in the water. The recommended range for total alkalinity is between 80 ppm and 150 ppm. If the chemistry of the water is not within this range, you will have difficulty adjusting the pH level, which will affect your adjustments for the proper amount of free available chlorine. If the alkalinity of your spa water is high, it is advisable to drain the water from the spa, refill and begin the balancing process over again. Purge and sanitize your spa (according to instructions in "Equipment Set-Up" section of the "Installation Instructions") and clean the spa surfaces thoroughly before refilling with fresh water. Then re-establish water chemistry. If the spa is used heavily, change the water at least every month.

WATER QUALITY DEFINITIONS

pH: A chemical term used in expressing relative acidity or alkalinity in numeric values, with 7.0 usually regarded as neutral, and for purposes of this manual, indicating pure water. From 7 to 0 indicates increasing acidity, and 7 to 14 indicates increasing alkalinity.

PPM: Parts per million.

Free chlorine: Chlorine that has not combined with other chemicals and that is available to destroy bacteria in the spa water.

Trichlor: A form of chlorine used in pool or spa water treatment; usually supplied in tablet form. Not recommended because of its higher acidic nature and slow dissolving action. Prolonged contact with the spa shell may bleach or permanently mark the shell.

Sodium dichlor: The type of chlorine that is recommended for spa use, as it is available in fast dissolving granular form. It is neither excessively acid nor alkaline in character and does not readily dissipate in higher water temperatures.

Calcium hypochlorite: A granular chlorine product that is inexpensive and effective but not recommended because

it often tends to form calcium deposits on heater parts and plumbing fittings and leaves an unattractive film on the spa at the water line.

Sodium hypochlorite: A liquid chlorine product that is inexpensive and effective but not recommended because the liquid is readily spilled onto the spa or a surrounding area, causing permanent damage. It has limited effectiveness at high water temperatures and readily affects pH balance.

Total alkalinity: The measure of the amount of alkaline materials (such as carbonates, bicarbonates and hydroxides) in the water. High alkalinity inhibits the effectiveness of chemicals to change the pH. If the alkalinity of your spa water is high (above 150 ppm), it is advisable to drain the water from the spa and begin the balancing process over again. Low total alkalinity (below 60 ppm) could be corrosive and damage your spa system.

Superchlorination: (Also referred to as "shock treatment".) The addition of an above-normal level of disinfectant to kill any bacteria or algae that might have become resistant to normal levels of disinfectant.

MAINTENANCE

Water Level/Drain

The water level in the spa must be maintained at its normal level. Evaporation and splashing will cause the water level to drop.

When concentrations of impurities from evaporation, water quality chemicals, body oils, perfumes, dirty feet, and winds, etc., accumulate in the spa and cannot be filtered out, it is necessary to drain your spa and refill it with fresh water. This should be done every 2 months or more often depending on the amount of use.

After draining the spa, clean the spa shell, suction covers, skimmer, and filter, then close the drain valve and refill the spa with fresh water. Check the pH level and maintain water quality.

NORMAL WATER LEVEL

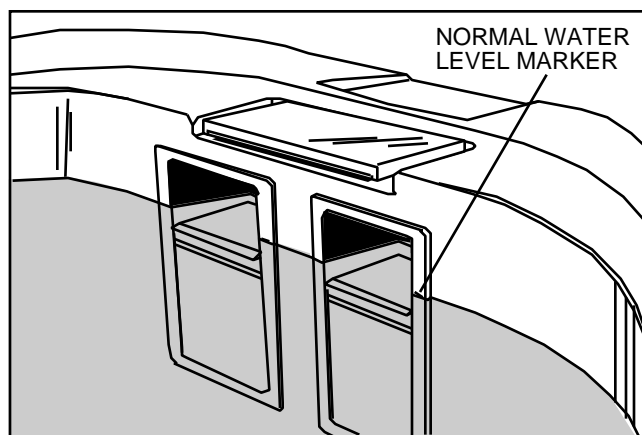

The suction covers located in the foot well area should be checked at least once a week for collected debris, such as leaves, hair, etc., and cleaned as necessary. It may not be necessary to remove the suction cover to clean it, but if you need to, remove the center screw with a Phillips type screwdriver and clean the cover by flushing with water from a hose.

CAUTION: Be sure to replace the suction cover immediately after cleaning. It is a safety device and must be in place over the suction fitting to minimize potential hazard of hair and body entrapment.

If heavy rains raise the spa water level, drain the spa to its normal level.

The optional rigid spa cover, when in place over the spa, will help reduce evaporation and control the amount of debris entering the spa when the spa is not occupied. In addition, its use will reduce energy consumption.

Skimmer Basket Maintenance

The basket located in the skimmer of the spa should be checked at least once a week for collection of debris, such as leaves, hair, etc., and cleaned as necessary. To clean the basket, remove it from the skimmer by pulling it out; then backflush it with a garden hose and reinstall.

FRONT ACCESS SKIMMER/FILTER

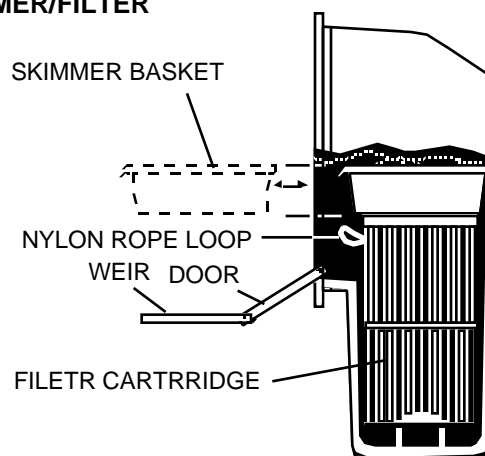

Filter Maintenance

The filters should be checked periodically. In normal use, check the filters at least once a month. Keep the filters clean; obstructed filters reduce water quality and inhibit proper system performance.

A removable filter cartridge is located inside each skimmer. To remove it, pull open the skimmer door by the handle located in the middle of the door. Slide the basket out, then pull the filter cartridge upward and out of the housing by the loop at the top of the filter. Clean the filter by separating the folds of the filter and spraying with fresh water from a garden hose. Then reinstall the cartridge in the housing and replace the basket, reversing the above procedure.

Oils will coat the filter, resulting in a reduced flow. To remove such materials, soak the cartridge in a plastic pail containing a commercial filter cleaning solution (available from your Jacuzzi Whirlpool Bath dealer or most pool supply stores). Follow the manufacturer's instructions for use. Another method is to soak the filter cartridge in a plastic pail containing a mild solution of trisodium phosphate (TSP) and water. An hour of soaking time is usually required to break down oil coatings from the cartridge. Use a stronger solution of TSP and water to remove algae. Most hardware or paint stores stock TSP. Use the same method of cleaning when the cartridge becomes plugged with clay or vegetation.

Replacement cartridges are available through your Jacuzzi Whirlpool Bath Dealer.

MAINTENANCE

Automatic Filtration/Maintenance

The spa should be covered to keep out debris. The filter cycle should be run at least two hour per day to maintain water quality. If your equipment pack has a timer installed, the timer may turn on the filter automatically each day for you in your absence. Your timer may also function to turn on the heater to maintain a certain water temperature. (Refer to optional switch/timer instructions.)

During prolonged periods of no use, the evaporation of water from the spa will cause the water level to fall below the skimmer level.* Long periods (two weeks or more) without water quality maintenance are not recommended. If spa water care cannot be maintained, turn off the main service panel switch (or sub-panel switch), drain and cover the spa.

Another means of maintaining minimum water quality while you are away for less than two weeks is to follow the procedure outlined for winterizing your spa in a warm climate. (See Winterizing.) Note: We do not recommend using this procedure if you are absent during the summer, when algae build-up is most likely.

Always keep your spa covered when not in use to reduce heat loss and evaporation and to prevent debris from falling in.

***Warning: If motor/ pump(s) is activated when the spa water is low, when the spa has been drained, or when the pump has lost its prime, the pump could become irreparably damaged.**

Winterizing

In a climate where winter temperatures are below freezing, follow this procedure when the spa will NOT be used:

Note: If the spa is to be used during winter in a cold climate, see warm climate instructions below.

1. Turn off the power to the equipment pack.
2. Drain the spa and equipment.

Note: If your spa is installed below ground and the ground water level in your area is high or drainage is poor, do not drain the spa (except for cleaning), as hydrostatic pressure may lift the spa out of the ground. Follow warm climate instructions for winterizing.

3. Remove the filter cartridges, clean them, and store them dry.
4. Remove the lower 1/4" plugs from the face of each pump housing, drain the pumps, then replace the plugs.
5. Obtain pure glycerine (Glycerol) from a druggist or other source. Mix 2 parts of glycerine to 1 part water and pour approximately one cup into each pump at the upper drain plug opening. A syringe or other similar device may speed up this process. Re-insert upper drain plug. **Do not use automotive anti-freeze.**

After the spa has drained keep water and debris out by covering with a water-proof cover.

Before using the spa again, see filling instructions in appropriate Priming Procedure.

In a warm climate where there are occasional freezing temperatures, follow this procedure:

1. Set the thermostat on the heater to its minimum temperature which, typically, is between 45°-65° F.
2. Run filter cycle daily during freezing conditions.
4. Maintain a chemical balance. (See Water Quality section.)
4. Use optional rigid spa cover for increased energy efficiency. This procedure allows usage of the spa during winter months with a minimum energy requirement.

CAUTION: Not winterizing will cause irreversible damage (at freezing temperatures) to the pump and or plumbing lines.

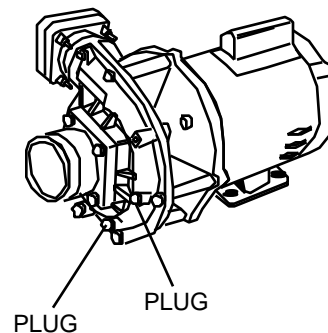

MAINTENANCE

Cleaning Your Spa

Your Cirrus IG spa shell consists of two layers of plastic materials. Its smooth top surface of acrylic is tough and durable and contains concentrated color. This is supported by a substantial thickness of fiberglass-reinforced polyester resin. A catalyst causes a chemical reaction during manufacturing that bonds these layers permanently into a hard, strong material. With a minimum amount of care and cleaning, your whirlpool spa will look new for years.

To clean your spa, simply use a mild, non-abrasive liquid detergent, isopropyl alcohol, or commercially prepared spa cleaner. **Do not use abrasive cleaners.** You can protect and restore the gloss to a dulled surface by applying Meguiar's #10 Mirror Glaze, which is a product specifically designed for use on acrylic finishes. If Meguiar's is not available, an acrylic polish of equal quality or automotive paste wax will do.

Use a spa cleaner for residue buildup at the water level of the spa surface. This may be applied to the acrylic surface with a soft cloth and wiped clean. Use sparingly in small amounts to avoid contaminating the spa water. If the spa is heavily soiled, it may be advisable to lower the water level 2 - 3 inches before cleaning, then refill to normal level.

Covering Your Spa

An optional rigid spa cover is available to place on top of the spa. The use of this cover will help to reduce energy costs by minimizing heat loss and evaporation from your spa. In addition, the attractive spa cover is an effective means of preventing debris such as leaves and dirt from entering your spa when not in use. Follow the instructions for use and care provided with the spa cover.

CAUTION: While the spa cover is rigid it is not designed to support any weight. Therefore, as a safety precaution and to preserve the life of your cover, you must not sit, stand, or lie on it; nor should you place objects of any kind on top of it.

Jacuzzi Whirlpool Bath does not guarantee or warranty this cover. Refer to spa cover manufacturer's information provided with the cover.

Repairs to the Acrylic

Minor scratches which do not penetrate the color finish (acrylic) can be removed with 600-grit wet/dry sandpaper. Restore the glossy finish with Meguiar's #10 Mirror Glaze or comparable automotive paste wax.

Major scratches or gouges which penetrate the acrylic surface will require refinishing. Ask your Jacuzzi Whirlpool Bath Dealer for special instructions.

TROUBLESHOOTING GUIDE

PROBLEM	PROBABLE CAUSE	REMEDY
1. Water will not heat.	<ul style="list-style-type: none"> A. No power to the heater. B. Thermostat set too low. C. Pressure switch set too high on gas heater. D. Failure of heater thermostat. E. Filter pump not on. 	<ul style="list-style-type: none"> A. Check circuit breaker. B. Reset thermostat. C. Adjust pressure switch. D. * E. Check circuit breaker.
2. Water not clean.	<ul style="list-style-type: none"> A. Filters clogged (dirty). B. Skimmer basket clogged. C. Clogged or blocked suction strainer. D. Improper maintenance. E. High content of solids in water. 	<ul style="list-style-type: none"> A. Clean or replace. B. Clean. C. Clean. D. See Maintenance/Water Chemistry. E. Drain and refill spa.
3. Abnormal water usage.	<ul style="list-style-type: none"> A. Excess evaporation.. B. Leak in plumbing line. 	<ul style="list-style-type: none"> A. Use spa thermal cover. B. Repair leak.
4. Low water flow from jets.	<ul style="list-style-type: none"> A. Only filter pump running. B. Only whirlpool pump running. C. Dirty filter(s). D. Plugged strainers. E. Low water level. F. Shut-off valves closed. G. Suction, skimmer, or discharge partially clogged. H. Worn or damaged pump seal. I. Foreign object lodged in pump. 	<ul style="list-style-type: none"> A. Turn on whirlpool pump. B. Turn on filter pump. C. Clean and replace. D. Clean. E. Fill spa to middle of skimmer opening. F. Open valves. G. Clean strainers or skimmer baskets. H. * I. *
5. No water flow from jets.	<ul style="list-style-type: none"> A. Circuit breaker tripped. B. Shut-off valve closed. C. Low water level. D. Leak in suction line, discharge line or connections. E. Pump or motor faulty. F. Pumps lost prime. 	<ul style="list-style-type: none"> A. Reset circuit breaker. B. Open valves. C. Fill spa to middle of skimmer opening. D. Repair leaks. E. * F. Prime pumps
6. Noisy pump and motor.	<ul style="list-style-type: none"> A. Leakage of air into suction. B. Blocked suction. C. Vibrating parts attached to motor or support brackets. E. Damaged or worn motor bearings. F. Impeller rubbing inside case. G. Debris inside pump. 	<ul style="list-style-type: none"> A. Locate and repair leaks. B. Clean suction strainers. C. Tighten fasteners. E. * F. * G. *

*** Note:** The skills and tools necessary for the safe repair of this spa require the services of qualified service personnel. Contact your Jacuzzi Whirlpool Bath Authorized Service Agent or Dealer.

TROUBLESHOOTING GUIDE

PROBLEM	PROBABLE CAUSE	REMEDY
7. Water leakage at pump shaft. (rotating connection between pump and motor).	A. Worn or damaged pump seal.	A. *
	B. Foreign matter trapped in pump.	B. *
8. Motor will not start.	A. Optional timer or switch set at OFF.	A. Turn to ON.
	B. Circuit breaker tripped or in OFF position.	B. Reset circuit breaker.
	C. Locked shaft or impeller.	C. *
	D. Disconnected or defective wiring.	D. *
	E. Defective starting switch inside motor.	E. *
	F. Motor winding burned out.	F. *
	G. Auxiliary switch malfunction.	G. *
9. Motor stops.	A. Optional timer or switch set at OFF.	A. Turn to ON.
	B. Circuit breaker tripped or in off position.	B. Turn to ON.
	C. Switch failure.	C. *
	D. Motor overload condition.	D. Let cool for one hour. Motor overload will reset, then start again. If problem persists, contact your Jacuzzi Whirlpool Bath dealer for service.
	E. Auxiliary switch malfunction.	E. *
10. Will not hold prime.	A. Air leak through faulty or open vent valves.	A. Close or repair vent valve.
	B. Water or air leak in system plumbing.	B. Repair leak.
	C. Low water level.	C. Fill spa to middle of skimmer opening.
	D. Faulty check valves.	D. Replace valves.

*** Note:** The skills and tools necessary for the safe repair of this spa require the services of qualified service personnel. Contact your Jacuzzi Whirlpool Bath Authorized Service Agent or Dealer.

**PRODUCT SPECIFICATIONS ARE SUBJECT TO CHANGE WITHOUT NOTICE.
USE INSTALLATION INSTRUCTIONS SUPPLIED WITH PRODUCT.**

Jacuzzi Whirlpool Bath has obtained applicable code (standards) listings generally available on a national basis for products of this type. It is the responsibility of the installer/owner to determine specific local code compliance prior to installation of this product. Jacuzzi Whirlpool Bath makes no representation or warranty regarding, and will not be responsible for any code compliance.

JACUZZI WHIRLPOOL BATH

Jacuzzi Whirlpool Bath National Headquarters
P.O. Drawer J, Walnut Creek, CA 94596 (510) 938-7070
Service Support: Call (800) 288-4002

©1993 Jacuzzi Whirlpool Bath D492000 9/93



Printed on Recycled Paper

Printed in the U.S.A.